

Y Branch

Ordering Information

- When ordering, specify material, gauge (if non-standard), dimensions A, B, C, end styles, and angle (standard 60°, optional 90°).
- Both B & C each must be at least 50% of A, with B or C being at least 80% of the opposite leg.
- Flange Leg: Length = 4.5"
Height = A + 4"

14 Gauge Y Branches:

- Any Branch with B, or C end smaller than 8" will be hybrid. (Smaller section will be a lighter gauge.)

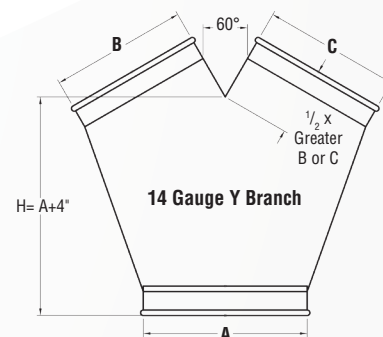
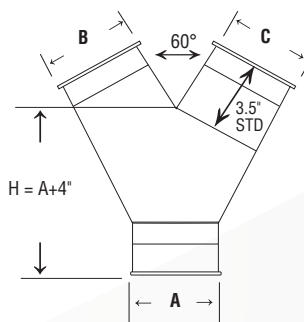
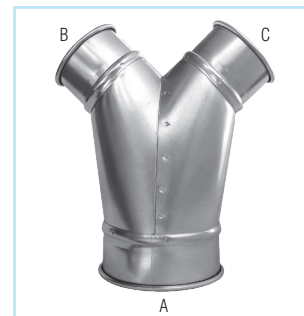

Please carefully note Nordfab Y Branch End Label designations (ABC)

Construction

Seam: Longitudinal seam is lapped, spot welded, and caulked on standard gauges. 14ga and 12ga - Solid butt welds.

Collars: Located on the exterior side of each port and considered as air flow non-directional. Collars have a laser welded longitudinal seam. If airflow directional product is required, it must be stated on the PO and additional cost may be incurred. A raised lap seam and spot weld are used for attaching the collar to the body and no caulking is used. If caulking is required, additional cost may be incurred. 14ga and 12ga - Collars have a plasma welded longitudinal seam.

Optional End Styles

Standard QF end can be changed to Raw ID (RI), Raw OD (RO), No Fitting (NF), Hose Adapter (RF), Flat Flange (FFL), Angle Flange (AFL), or Van Stone (VS).

QF Material Options

		Galv			SS		
		Size (inches)			Size (inches)		
		Gauges	Min. Ø	Max. Ø	Gauges	Min. Ø	Max. Ø
Standard	22	3	12	Standard	22	3	12
	20	13	24		20	13	24
Optional	18	4	24	Optional	18	8	24
	16	8	24		16	8	24
	14	8	24				

Flanged Material Options

		Galv			SS		
		Size (inches)			Size (inches)		
		Gauges	Min. Ø	Max. Ø	Gauges	Min. Ø	Max. Ø
Standard	22	3	12	Standard	22	3	12
	20	13	24		20	13	24
	18	26	30		18	26	30
	16	32	40		16	32	40
	14	42	50		14	42	50
Optional	12	52	72	Optional	20	4	12
	20	4	12		18	4	24
	18	4	24		16	8	30
	16	8	30				
	14	8	50				
	12	10	72				
	10	12	72				

A Ø in.	Length in.	Weight Lbs
3		1.50
4		1.75
5	QF or Raw ends:	2.00
6	To manufacture,	2.75
7	B and C must be 50% or	3.25
8	greater of A;	4.50
9	B and C must be within	5.25
10	80% of each other.	6.75
11	Example: if B=10", then	8.00
12	C must be at least 8" or	10.25
13	greater.	12.50
14	Length =	14.00
15	A + 4"	15.75
16	14ga QF or Raw ends:	17.00
17	To manufacture,	18.50
18	B and C must be 50% or	20.00
19	greater of A;	24.50
20	B and C must be within	29.00
21	80% of	36.00
22	each other.	39.50
23	Example: if B=15", then	47.00
24	C must be at least 12" or	53.50
25	greater.	58.00
26	Length =	69.00
27	A + 4"	78.00
28		93.00
29		107.00
30	Angle Flange or	112.05
31	Flat Flange ends:	115.00
32	Flanged ends:	120.94
33	B or C ports leg length is	124.00
34	4.5" min.	129.83
35	14ga or 12ga with	133.00
36	Flanged ends:	137.78
37	B or D ports leg length is	143.00
38	1/2 greater of B or D	148.47
39		152.00
40		157.81