



MADE
IN THE **USA**

Product Description:

- Kit Includes:
 - RS005-0512 Respiratory Hygiene Station - Locking
 - Holds two boxes of face masks, one or two boxes of facial tissues or one box of gloves, and one hand sanitizer dispenser
 - Made of Quartz Beige Powder-Coated Aluminum
 - KS010-0412 Floor Stand
 - Column with square base and mounting top plate for Respiratory Hygiene Station
 - Made of Quartz Beige Powder-Coated Steel
 - MP-075 Sign Holder - Horizontal
 - Holds 11" x 8.5" signage horizontally (Cover Your Cough signage can be downloaded at www.BowmanDispensers.com)
 - Made of Clear PETG Plastic
- All hardware included for assembly as a free standing unit

Primary Area for Product Usage:

- Emergency and admitting departments, all ports of entry, outpatient radiology/MRI, outpatient labs and pharmacies

Dispenses:

Respiratory Hygiene Station holds most brand name boxes:

- Two boxes of face masks up to 7.75"W x 5.00"H x 4.75"D (19.7 cm x 12.7 cm x 12.1 cm)
- One large or two small boxes of tissues or one box of gloves up to 5.50"W x 10.00"H x 4.75"D (13.7 cm x 25.4 cm x 12.2 cm)
- One hand sanitizing gel or foam dispenser - mountable area 8.4"W x 14.8"H x 5.0"D (21.2 cm x 37.5 cm x 12.7 cm) [Note: Refer to automatic dispensing specifications on detection distance requirements.]

Product Specifications (overall assembled dimensions):

- 18.00"W x 57.98"H x 18.0"D (45.7 cm x 147.3 cm x 45.7 cm)
- 22.0 lbs (10.0 kg) - approximated

Package Specifications:

- Package Quantity: 1 complete kit per case
- 36"L x 20"W x 6"H (91.4 cm x 50.8 cm x 15.2 cm)
- 26.0 lbs (12.7 kg) - approximated



Sanitizer, face masks, and tissues not included

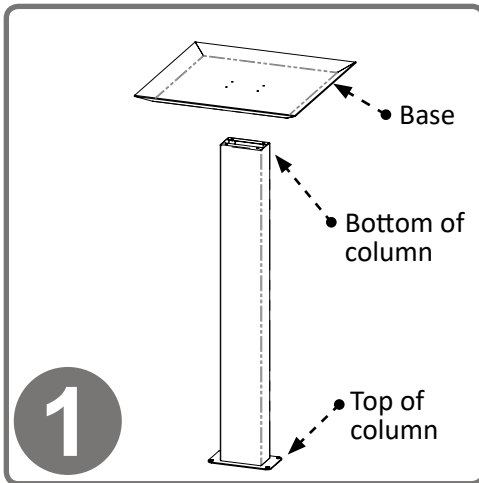

To secure base to column, turn column upside down (with top plate down) and place base inverted, as shown, on column.

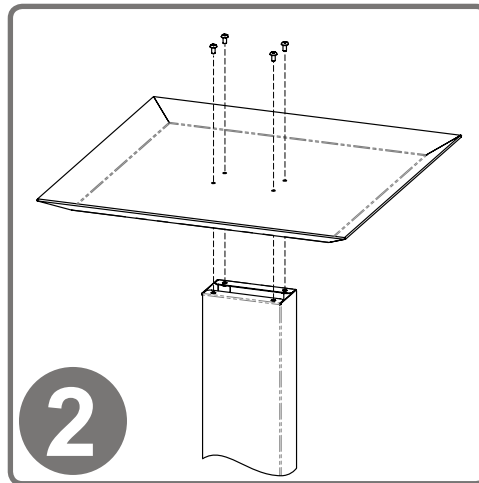

Use Phillips screwdriver to secure base to column with (4x) screws (10-32 x 5/16").

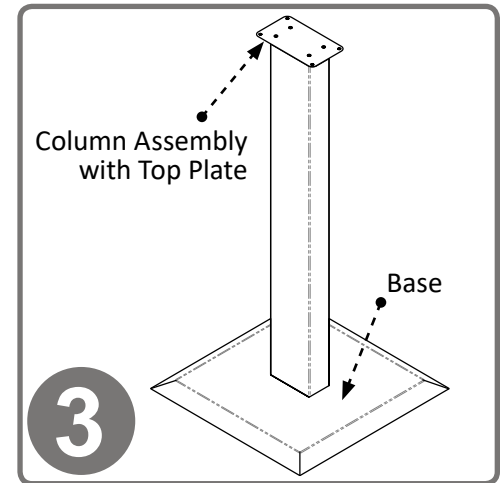

Turn stand right side up, so the base is on the floor.

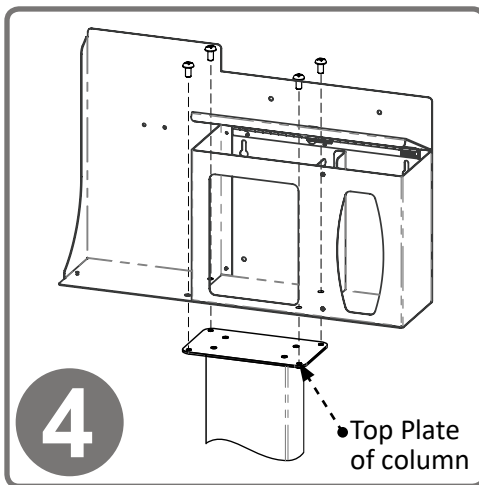

Attach the RS005-0512 Respiratory Hygiene Station to the column using (4x) screws included with stand. One pair of screw holes is located in the hand sanitizer dispenser section; the second pair is inside the facemask section and can be accessed with the lid open. Tighten all screws.

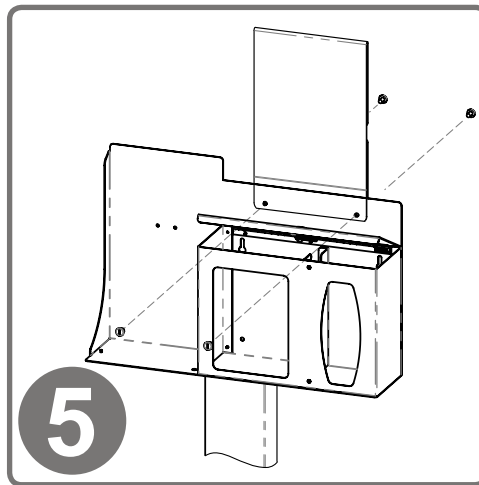

To mount the MP-070 Sign Holder, sandwich the holder over the top edge of the dispenser, lining up holes. With a flathead screwdriver, attach using (2x) barrel screws included with sign holder.

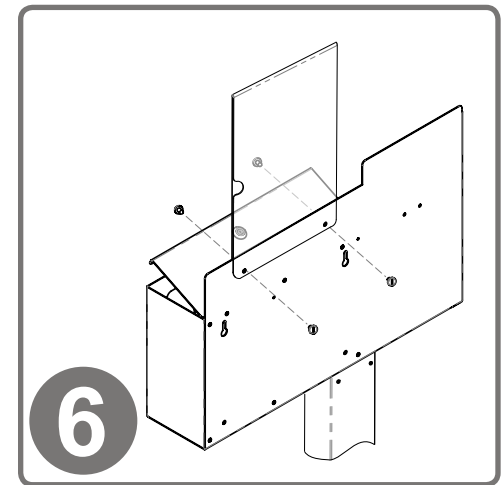

Sign holder overlaps front and back of dispenser as shown.

Parts included:

- Column
- Base
- Hygiene Station
- Sign Holder
- Hardware
 - (8x) Screws: (4x) for stand, (4x) to attach hygiene station (Phillips type 10-32 x 5/16")
 - (2x) barrel screws for attaching sign holder

Tools Required:

- Phillips Screwdriver
- Flathead Screwdriver

**RS005-0512**

Powder-Coated Aluminum

KS010-0412

Powder-Coated Steel

MP-075

PETG Plastic

Material Characteristics**Designed for Long-Term Use**

Our powder-coated aluminum dispensers resist corrosion, chipping, and flaking. It is lightweight, yet high in strength. This material will provide long-lasting products that hold up well, even in tough environments.

Powder-coated aluminum is ideal for dispensers used in a healthcare or industrial settings. It is impact resistant and is not affected by extremes in temperature.

Dispensers made of powder-coated aluminum are clean, bright, and attractive, creating a professional appearance.

Designed for Long-Term Use

Our steel dispensers and stands are coated with polyester powders which makes them highly resistant to corrosion.

Powder-coated steel is ideal for dispensers used in a healthcare or an industrial setting because it is impact resistant and is not effected by extremes in temperature.

Dispensers and stands made of powder-coated steel are both attractive and functional, providing years of service.

Designed for Long-Term, Heavy-Duty Applications

Copolyester resin is designed for heavy-duty applications, and is used by BOWMAN® Dispensers. We never use acrylic in our products.

Copolyester (PETG) is typically 15-20 times tougher than general purpose acrylic. PETG is made to withstand handling and reduce losses due to breakage.

PETG resists a variety of chemicals and commonly used cleaning agents, such as PDI wipes. It is tough and durable (not brittle), providing years of trouble-free functionality and long life.

Clear optical characteristics mean the viewer can see the content, read text, and see true colors through the material. It complies with FDA regulations for food contact.

Care and Cleaning

For best results, clean by washing the surface with a diluted solution of a mild, non-abrasive detergent in cold or warm water and a non-abrasive cloth. Standard hospital cleaning supplies can be used.

Dry with a soft cloth. Do not use any solvent-based materials, abrasives (e.g. Scotch-brite, steel wool), or apply excessive force during cleaning.

For best results, clean by washing the surface with a diluted solution of a mild, non-abrasive detergent in cold or warm water and a non-abrasive cloth. Standard hospital cleaning supplies can be used.

Dry with a soft cloth. Do not use any solvent-based materials, abrasives (e.g. Scotch-brite, steel wool), or apply excessive force during cleaning.

Most cleaning chemicals do not weaken the surface or cause damage to the material. Suggested cleaning method is to use a soft cloth, warm water, and mild soap.