



OPERATOR'S MANUAL

BATTERY CHARGING RACK **MODEL 6086**

ASSOCIATED EQUIPMENT CORPORATION
5043 Farlin Avenue
Saint Louis, Missouri 63115

These instructions contain important safety and operating instructions on the Model 6086 charging distribution rack. **SAVE THESE INSTRUCTIONS!** You may wish to refer to them at a later date.

SAFETY INFORMATION

DANGER - RISK OF EXPLOSIVE GASES

Working in the vicinity of a lead acid battery is dangerous. Batteries generate explosive gases during normal operation. These gases may be ignited by spark or flame and burn back through the vent hole to explode inside the battery cell. Such an explosion is dangerous because battery pieces and battery acid may cause great harm to anyone in the immediate area. Battery acid will cause burns to the skin and eyes if not immediately washed off with fresh water. For this reason it is of utmost importance that each time you use this charger you follow the instructions in the owners' manual exactly.

1. Always wear a face shield when working around a lead acid battery. Avoid rubbing or touching eyes while working near batteries.
2. Do not smoke, strike a match or cause a spark in the vicinity of a battery during charging.
3. Connect and disconnect battery leads only when Chargers supply cord is disconnected and all switches are in the off position.
4. Do not overcharge a battery - see Charger Instruction manual.
5. Use in a well ventilated area. Check local building codes for adequate ventilation.

PERSONAL PRECAUTIONS

1. Wear a face shield and protective clothing while working near batteries. Have plenty of fresh water and soap available for washing and rinsing areas of the skin which you may accidentally get acid on. If acid touches your skin, wash immediately and rinse well. Do not hesitate to see a doctor if there is any question in your mind about your well being.
2. Avoid touching your face and eyes with your hands. In the event acid enters the eyes, immediately flood the eyes with clean running water and rinse for at least 10 minutes. Get medical attention as soon as possible. Do not use eye drops or any medications unless instructed by a doctor.
3. Do not allow anyone to smoke, light cigars or cigarettes or have a flame in the vicinity of the batteries. Do not allow an engine to be cranked or run in the vicinity.
4. Do not attempt to charge a frozen battery, it could explode.

OPERATING PRECAUTIONS.

1. Always turn the battery charger off before connecting or disconnecting batteries from the rack.
2. Do not readjust the clamps on a battery while the charger is on. Turn charger off before adjusting.
3. Do not allow Positive (+) Red clamps to touch Negative (-) Black clamps. Use extreme caution while making connections to the batteries.

4. Determine correct battery polarity before attaching clamps to the battery. The Positive (+) Red clamp goes to the positive battery post. The Negative (-) Black clamp goes to the negative battery post. When attaching the rack to the charger, double check all connections with a voltmeter.
5. For safe connections, clean corroded clamps in a baking soda and water solution. When doing this be sure the charger is turned off and all batteries are disconnected from the charging system. Do not place red clamps and black clamps into a container of baking soda at the same time. Do only black or only red at any one time.

6086

ASSEMBLY INSTRUCTIONS

1. Support beams lock into notches in legs by hammering into place. The 48" Support beam with the Warning Label attached should be placed in the front top position.
2. Install two 48" and two 12" Support beams to the four legs to form the bottom shelf support and lock the legs upright.
3. Place one shelf board on lower shelf supports.
4. Lay the Cable system down so as to allow the connecting cables to pass across the lower shelf with the Buss Bar and Clamps to either side of the shelf.
5. Install two 48" and two 12" Support beams half way up the legs.
6. Attach the connecting cables to the rear center shelf support bracket using three wire ties provided.
7. Place one shelf board on middle shelf supports.
8. Attach the Bus Bar assemblies to the legs using bolts, washers and nuts provided. The Buss Bar assemblies should reach the third or fourth hole above the middle shelf.
9. Attach cables from the charger to either end of the rack by removing the insulator boots, attaching the cables and reinstalling the boots as illustrated in figures 1 and 2, using the hardware provided. Use extreme caution in maintaining the correct polarity of input cable. Positive should be connected to the Red clamps and Negative to the Black clamps.
10. Install two 48" and two 12" Support beams to form the top shelf support. Note: The 48" Support beam with the Warning Label should be installed as the Top Front support.
11. Place the last shelf board on top shelf supports.
12. It is recommended that the rack be fastened to a wall or other support to prevent tip over when removing a battery from the top shelf.

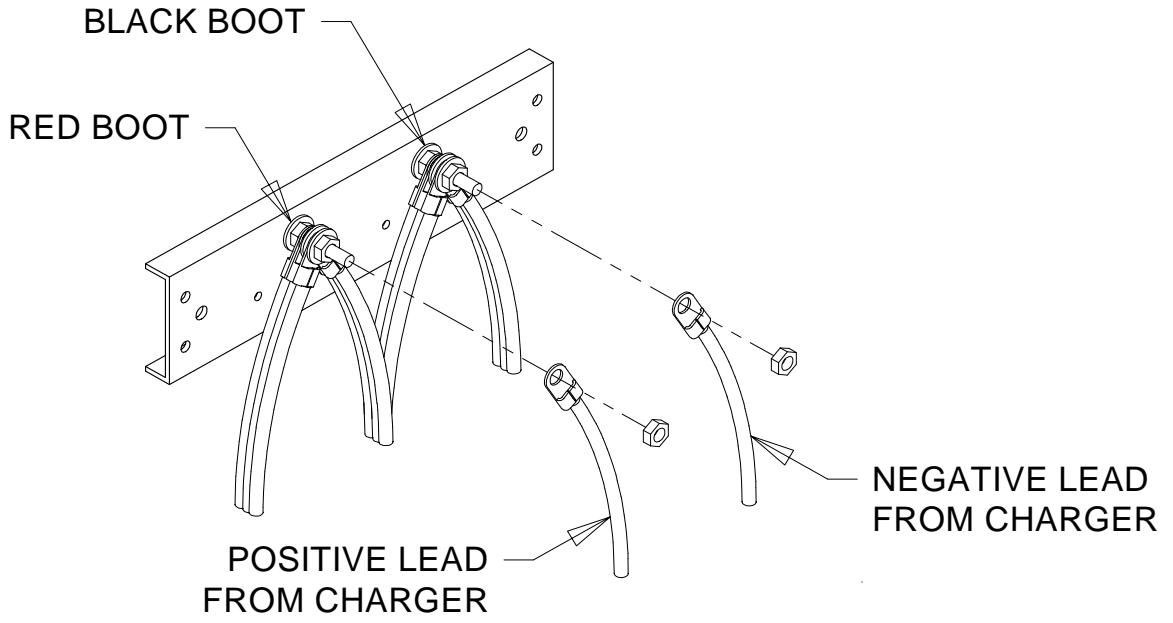
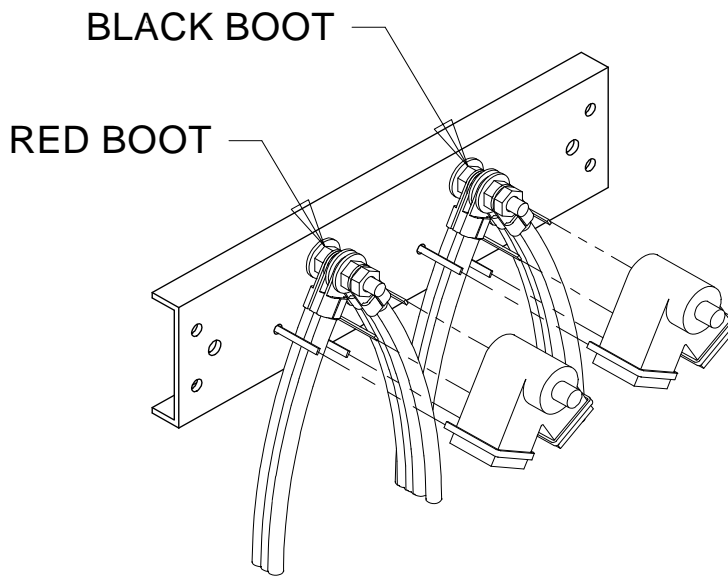

FIG. 1



NOTE:
BOOTS SHOWN UNATTACHED FOR CLARITY.

FIG. 2