

# INSTRUCTIONS

for

## FIELD TYPE R-C and TYPE SA BAROMETRIC DRAFT CONTROLS WOOD and OIL BURNING INSTALLATIONS

If at all possible, installation of these controls should be conducted by your stove dealer or a qualified service technician to assure safe and proper operation.

**NOTE:** Read all instructions carefully before starting installation. **SPECIAL TYPES OF INSTALLATION:** If draft control installation instructions differ from those of the heater manufacturer, follow heater manufacturer's instructions. Should the installer have questions pertaining to proper installation not covered in heater or draft control instructions, installer should consult with appliance dealer or qualified mechanic for necessary advice.

**CAUTION:** Do not install or operate a Field draft control or tee joint pipe that is bent or damaged.

**NOTE:** Field draft controls are designed and constructed for connection with CLASS "A" masonry or ALL-FUEL pre-fabricated chimney. Pre-fabricated chimneys must be listed by Underwriters Laboratories (UL) Inc., or in Canada by Canadian Standards Association (CSA).

### 1.0 INSTALLATION OF BLACK TEE JOINT (pipe section)

1.1 Remove draft control from black tee section of pipe with which it was shipped (see fig. 1). The black tee section will become a part of the smoke pipe between the stove and the chimney.

**LOCATION:** Black tee section should be placed: (see fig. 2)

- As close as possible to the heater.
- With open end of stub directed away from wall or walls nearest the heater.
- With front edge of stub straight up and down (perpendicular to floor).

1.2 Unless the heater manufacturer specifies an exact installation location and position, the draft control unit may be installed in either a vertical, horizontal or sloping smoke pipe.

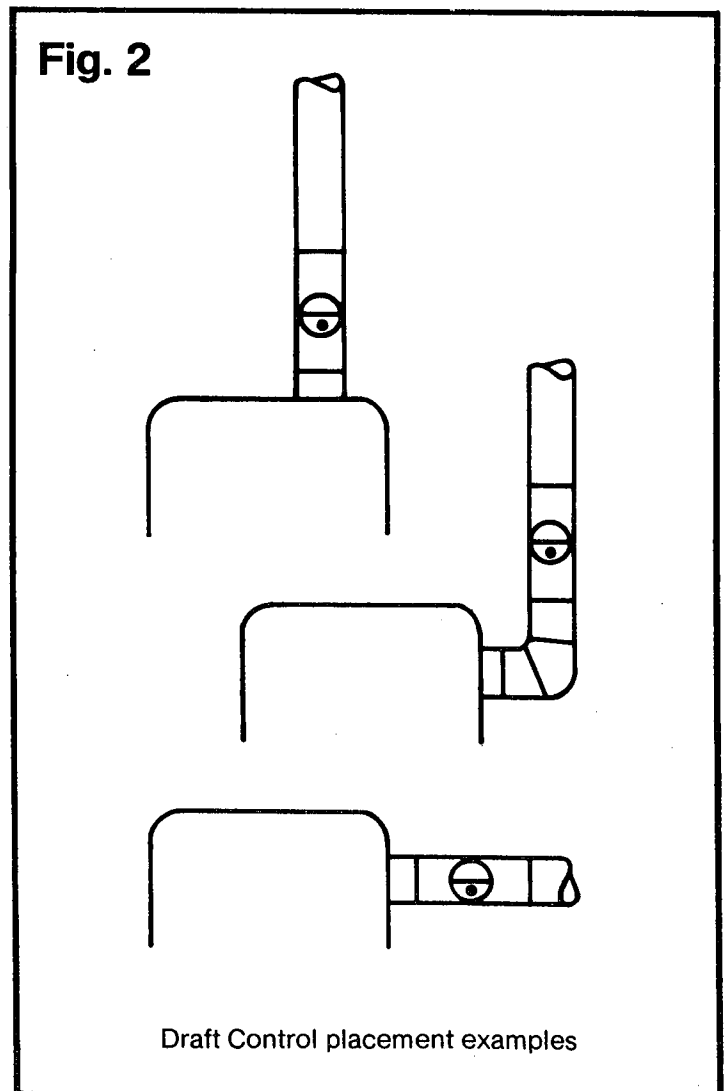
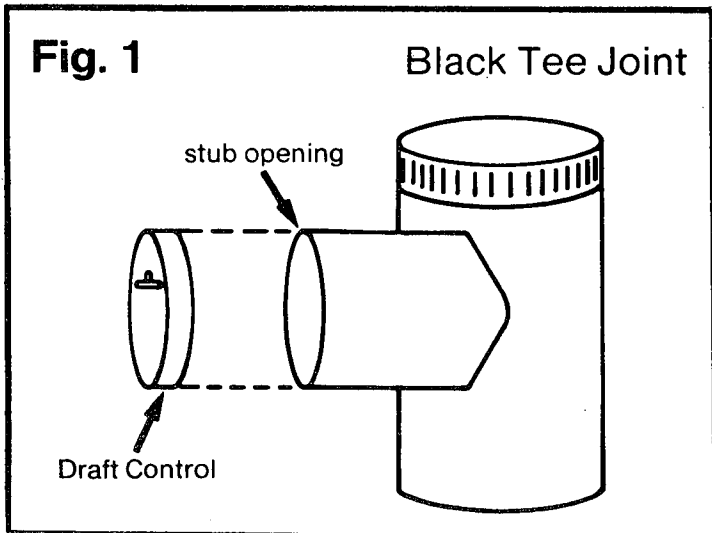

1.3 To function properly and safely, it is imperative that the draft control when installed in the tee joint stub, is pointing away from surrounding walls or obstructions (see fig. 3). Placement of draft control pointing toward nearby wall(s) or obstruction(s) could result in a hot spot on the exposed surface and subsequent fire hazard.

1.4 Regardless of location and position, the black tee stub opening MUST be plumb (perpendicular) for the draft control to function properly (see fig. 4). Use a plumb bob or spirit level across the vertical diameter of the stub opening to achieve proper plumb.

1.5 After the tee joint section location has been determined, secure the section with both ends to adjacent sections of standard smoke pipe. Three sheet metal screws placed at equal-distance around each end of pipe will hold it firmly in place.

## 2.0 PRE-MOUNTING SET-UP INSTRUCTIONS FOR MODEL SA

If you are installing the Field type SA draft control, you must make the following alterations before mounting this control on the tee joint.

2.1 Vertical Pipe Installation: The control is intended for a vertical smoke pipe installation as you receive it. If your installation is a vertical smoke pipe installation, proceed to the instructions detailed in section 4.0, for mounting draft control to tee joint.

2.2 Horizontal Pipe Installation: When installing the draft control as part of a horizontal smoke pipe, make the following change: Loosen the adjustment screw on the front of the gate sufficiently so that the weight on the back or inner side of the gate can be removed. Slip the special washers (the proper number, either one or two, is supplied loose, in each carton) between the rear weight on the back of the gate and re-assemble the weights and the screw.

(The special washers change the balance of the gate, to allow proper operation in a horizontal installation.) CAUTION: Do not use the washers with a vertical (upright) pipe installation. After this adjustment for a horizontal installation is made, proceed to instructions detailed in section 4.0, for mounting draft control to tee joint.

**Fig. 3**

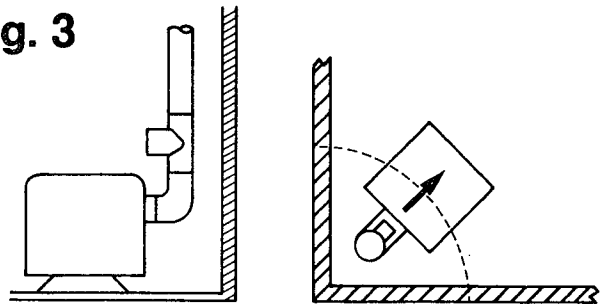

Point stub opening of Black Tee Joint away from nearby walls or obstructions.

**Fig. 4**

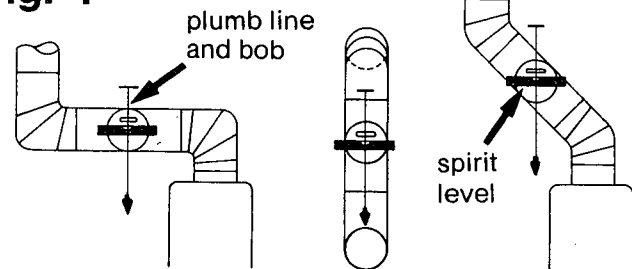

Black Tee Joint stub opening must be plumb (perpendicular).

Position Draft Control in stub opening so it is plumb and level.

## 3.0 PRE-MOUNTING SET-UP INSTRUCTIONS FOR MODEL R-C

If you are installing the Field type R-C draft control, you must make the following alterations before mounting control on the tee joint.

### 3.1 Vertical Pipe Installation:

- Adjustment weight must be in **RIGHT HAND SLOT** (marked "V") in bracket on gate.
- The arrow on flap at bottom of gate must line up with letter "V" on lower right part of gate. If it does not, remove flap, turn over and snap on to gate again. Flap can be removed by inserting small screw driver at the back side of the gate between the gate and the flap, then pulling downward on flap. After completing these steps proceed to the instructions detailed in section 4.0.

### 3.2 Horizontal Pipe Installation:

- Adjustment weight must be in **LEFT HAND SLOT** (marked "H") in bracket on gate.
- The arrow on flap at bottom gate must line up with letter "H" on lower left part of gate. If it does not, remove flap (see section 3.1 B above), turn over and snap on to gate again. After completing these steps, proceed to the instructions detailed in Section 4.0.

#### 4.0 MOUNTING DRAFT CONTROL TO BLACK TEE JOINT

4.1 Insert the draft control in the open end of the stub. Revolve it so it is right-side-up and imprinting on control reads normally. To function properly, the draft control must be mounted level and plumb in the tee joint stub. Using a carpenter's spirit level placed vertically across the ring, position the draft control so it is plumb and does not lean forward or backward (see fig. 4). Also, place the spirit level horizontally across the front, in line with the pivot pins on type R-C or in line with "V" notches in the ring on type SA and position the control so it sets true (level). Tighten locking screw to hold draft control in place (see fig. 5 or fig. 6).

#### 5.0 SETTING THE FIELD DRAFT CONTROL

##### 5.1 Type SA

To set the Type SA Control: Loosen the adjustment knob and slide it in the slot to the right to increase the draft and towards the left to reduce the draft. Hand tighten when in proper position. Unless heater manufacturer instructions state otherwise, make settings as follows: For a low or slow draft, set adjustment weight at the end of the slot marked "Lo". For medium fire, place at middle position and when maximum heat is required, set at the end of the slot marked "Hi".

##### 5.2 For Oil Burning Units:

When Type SA Control is used with an oil burning unit, adjustment setting of control should correspond with similar settings on the oil valve.

##### 5.3 For Wood Burning Units:

When Type SA Control is used with a wood burning unit, adjust the draft control when a good fire is burning. Normally, the best setting is the lowest possible that can be obtained without smoke coming back out of the firing door when it is slightly ajar. Keep lowering the draft setting until the stove begins to smoke back and then increase the draft slightly. Gradually increase further if more heat is desired.

##### 5.4 Type R-C

To set Type R-C Control: Turn adjustment weight counter-clockwise to loosen, slide in slot to proper position and tighten. Bracket is marked 2, 4, 6 and 8, which indicate draft settings of .02", .04", etc. (These are drafts in flue adjacent to control, not over-fire drafts.) Always set the control to maintain as low a draft as will give good combustion and meet the requirements for heat.

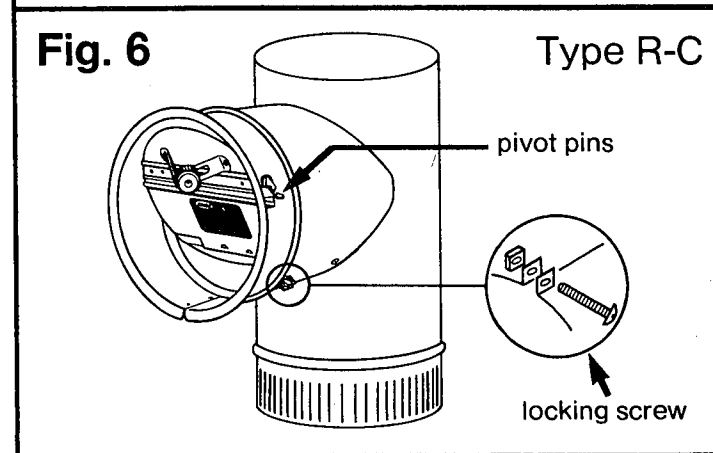
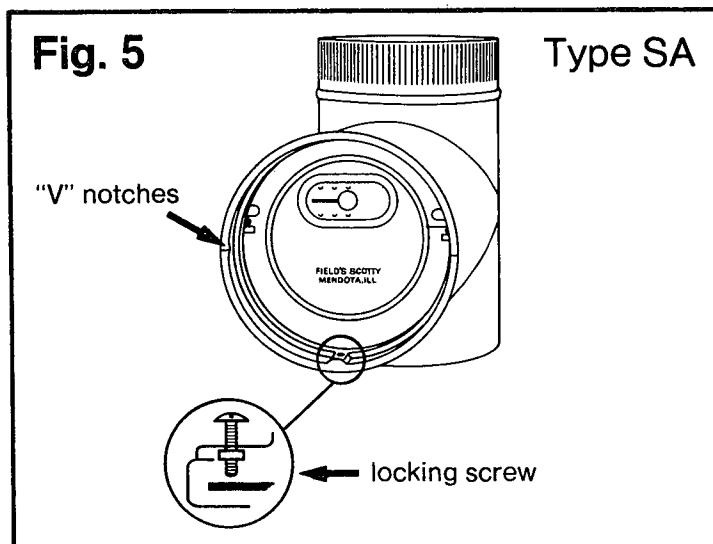

##### 5.5 For Oil Burning Units:

When R-C draft control is used with an oil burning unit, the burner must be fired when the adjustment of the control is made. Take draft readings over the fire. For a domestic oil burner the overfire draft should be approximately .02" to .03", although there are some makes of burners which require higher drafts. Consult with the burner manufacturer. There must always be enough draft so that the burner does not puff back into the room at the moment it starts, and there should be no objectionable smoke. It is essential that CO<sub>2</sub> readings be taken to determine the proper adjustments. (This test and others should be conducted by a qualified fuel oil dealer or appliance installer for your safety.)

##### 5.6 For Wood Burning Units:

When R-C draft control is used with a wood burning unit, adjust the draft control when a good fire is burning. Normally, the best setting is the lowest possible that can be obtained without smoke coming back out of the firing door when it is slightly ajar. Keep lowering the draft setting until the stove begins to smoke back, and then increase the draft slightly. Gradually increase further if more heat is desired.

## 6.0 MORE ON WOOD BURNING INSTALLATIONS

### 6.1 Creosote Build Up

Creosote, in a vaporized state, is present in the gases emitted by burning wood and is highly combustible in its solid and semi-liquid states. Creosote may build up on the interior surface of the chimney and subsequently reduce the draft opening. A DANGEROUS CHIMNEY FIRE MAY RESULT IF ANY APPRECIABLE CREOSOTE BUILD UP IS PERMITTED.

### 6.2 Adverse Conditions Conducive to Creosote Build up:

Creosote condenses from the flue gases more rapidly when the temperature in the chimney is cool. The amount of creosote build up is dependent on:

- The amount of moisture in the flue gases,
- The temperature of the stack,
- The rate at which the wood is burned,
- The amount of draft in the stack,
- How completely the combustible elements in the flue gases have been burned in the combustion chamber.

6.3 Most problems with creosote are due to insufficiently dry or cured wood, inadequate chimneys with low draft and cold walls (below 250°F.), and/or too low a rate of burning when little heat is required during spring and fall months.

### 6.4 Control of Creosote

Moisture in the flue gases may be controlled by:

- using properly seasoned fire wood
- mixing small pieces (preferably slab wood) with every full load.
- never using only large wood (usually less dry) during mild weather when combustion is relatively slow.

The temperature in the stack may be controlled by:

- using as short a length of stove pipe as possible between the appliance and the chimney.
- using an insulated flue pipe to connect the appliance to the chimney.

The amount of draft in the stack may be improved by:

- having as few bends as possible.
- insuring adequate chimney height and preventing air leaks.
- eliminating external obstructions in the chimney outlet.
- having only one appliance per flue.

### 6.5 Removal of Creosote

Accumulations of creosote in smoke pipe and chimney flue should be removed by dismantling and scraping connector pipes and by scraping and brushing flue until free of deposits. In many areas there are professional chimney cleaning services available to perform this cleaning operation.

### 7.0 Wood Burning Appliances with Thermostatically Controlled Shutters:

7.1 Some of the more complex designs of wood burning units are equipped with thermostatically operated shutters that automatically open and close to regulate the volume of air supplied directly to the fire. If for some reason this mechanism were to malfunction and stick open, it would feed the fire too much air.

A Field Type SA or R-C draft control properly installed and properly set, will automatically equalize the air supply and prevent the fire from burning out of control and overheating the unit. These draft controls are not to be considered a fail-safe system to compensate for faulty or improperly maintained equipment.

## FIELD CONTROLS

KINSTON, NORTH CAROLINA 28501  
PHONE 919-522-3031