



**Vestil Manufacturing Corp.**  
 2999 North Wayne Street, P.O. Box 507, Angola, IN 46703  
 Telephone: (260) 665-7586 -or- Toll Free (800) 348-0868  
 Fax: (260) 665-1339  
 Web: [www.vestilmfg.com](http://www.vestilmfg.com) e-mail: [info@vestil.com](mailto:info@vestil.com)

# CYL-P-X-LUG Instruction Manual



[CYL-P-4-LUG shown]

### Receiving Instructions

After delivery, remove the packaging from the product. Inspect the product closely to determine whether it sustained damage during transport. If damage is discovered, record a complete description of it on the bill of lading. If the product is undamaged, discard the packaging.

NOTE: The end-user is solely responsible for confirming that product design, use, and maintenance comply with laws, regulations, codes, and mandatory standards applied where the product is used.

### Replacement Parts and Technical Assistance

To order replacement parts, labels, and accessories, contact the technical service and parts department online at [http://www.vestilmfg.com/parts\\_info.htm](http://www.vestilmfg.com/parts_info.htm). Alternatively, you may request replacement parts and/or service by calling (260) 665-7586 and asking for the Parts Department.

### Table of Contents

Signal Words.....	2
Safety Instructions.....	2
Exploded View and Bill of Materials.....	3
National Standards.....	4
Using the Lifter.....	4
Record of Satisfactory Condition.....	5
Load Tests.....	5
Inspections and Maintenance.....	5 - 6
Labeling Diagram.....	6
Limited Warranty.....	6

## SIGNAL WORDS

This manual uses SIGNAL WORDS to direct the reader's attention to important safety-related messages. These messages describe uses of the product that could result in personal injury or property damage. Each signal word corresponds to a specific hazard level. The following are definitions of signal words that might appear in this manual.



Identifies a hazardous situation which, if not avoided, **WILL** result in **DEATH** or **SERIOUS INJURY**. Use of this signal word is limited to the most extreme situations.



Identifies a hazardous situation which, if not avoided, **COULD** result in **DEATH** or **SERIOUS INJURY**.



Identifies practices likely to result in product/property damage, such as operation that might damage the product.

## SAFETY INSTRUCTIONS

Vestil strives to identify all foreseeable hazards associated with the use of its products. However, material handling is dangerous and no manual can address every conceivable risk. Ultimately, the most effective way to prevent injury is to apply sound judgment whenever using this device.



Improper or careless use of this product could result in death or serious personal injuries.

- **Read and understand the entire manual before assembling, installing, using, or servicing the cylinder lifter.** DO NOT operate this device until you read and understand the entire instruction manual. Read the manual to refresh your understanding of proper use and maintenance procedures.
- This device is designed for lifting compressed gas cylinders. DO NOT pull, drag, or slide the lifter regardless of whether it is loaded or unloaded.
- DO NOT modify the product in any way UNLESS you first obtain written approval from Vestil. Unapproved modifications automatically void the **LIMITED WARRANTY** and might make the product unsafe to use.
- DO NOT remove or obscure labels applied to the unit.
- Inspect the product before each use.
- DO NOT use this device UNLESS all labeling applied to the lifter is readable and undamaged. See **LABELING DIAGRAM** on p. 6.
- DO NOT use this lifter if it is damaged, malfunctioning, or missing parts.
- This lifting device must only be used by designated persons and lifting device inspectors. Maintenance and test personnel should only use this device when necessary to perform their duties.
- DO NOT exceed the rated load/capacity of your lifter. Capacity figures are provided on product labeling. See **LABELING DIAGRAM** on p. 6.
- Only use the lifter to lift properly-sized gas cylinders. All cylinders loaded onto the lifter must be securely strapped to the lifter with the ratchet straps. The straps must prevent all cylinders from being able to move during the lift. Follow loading instructions in **USING THE LIFTER** on p. 4.
- Make sure that all straps and chains are not kinked or twisted.
- Distribute loads evenly on the lifter. The lifter floor must be substantially horizontal when the lifter is elevated. Slowly raise the loaded lifter a few inches above the ground to determine whether the load is distributed properly. Redistribute the load, if necessary, to achieve load balance.
- Center the hoist above the lifting lug to minimize swing as the lifter rises off of the ground. DO NOT side load the hoist.
- Carefully eliminate slack in the hoist line before raising the lifter. Lift and lower the lifter slowly and steadily. DO NOT suddenly lift or lower the lifter.
- DO NOT lift loads any higher than necessary. Keep the suspended lifter as close to the ground as possible while moving it.
- Avoid obstructions while moving the lifter.
- Stay clear of the lifter and load while the lifter is suspended. The lifter could swing or spin while elevated.
- NEVER lift people or lift suspended loads over people.
- DO NOT leave the lifter unattended while it is suspended. Land the lifter, unload it, and store the lifter in its designated storage location before leaving it.
- NEVER ride on the lifter.

## CYL-P-X-LUG EXPLODED VIEW AND BILL OF MATERIALS

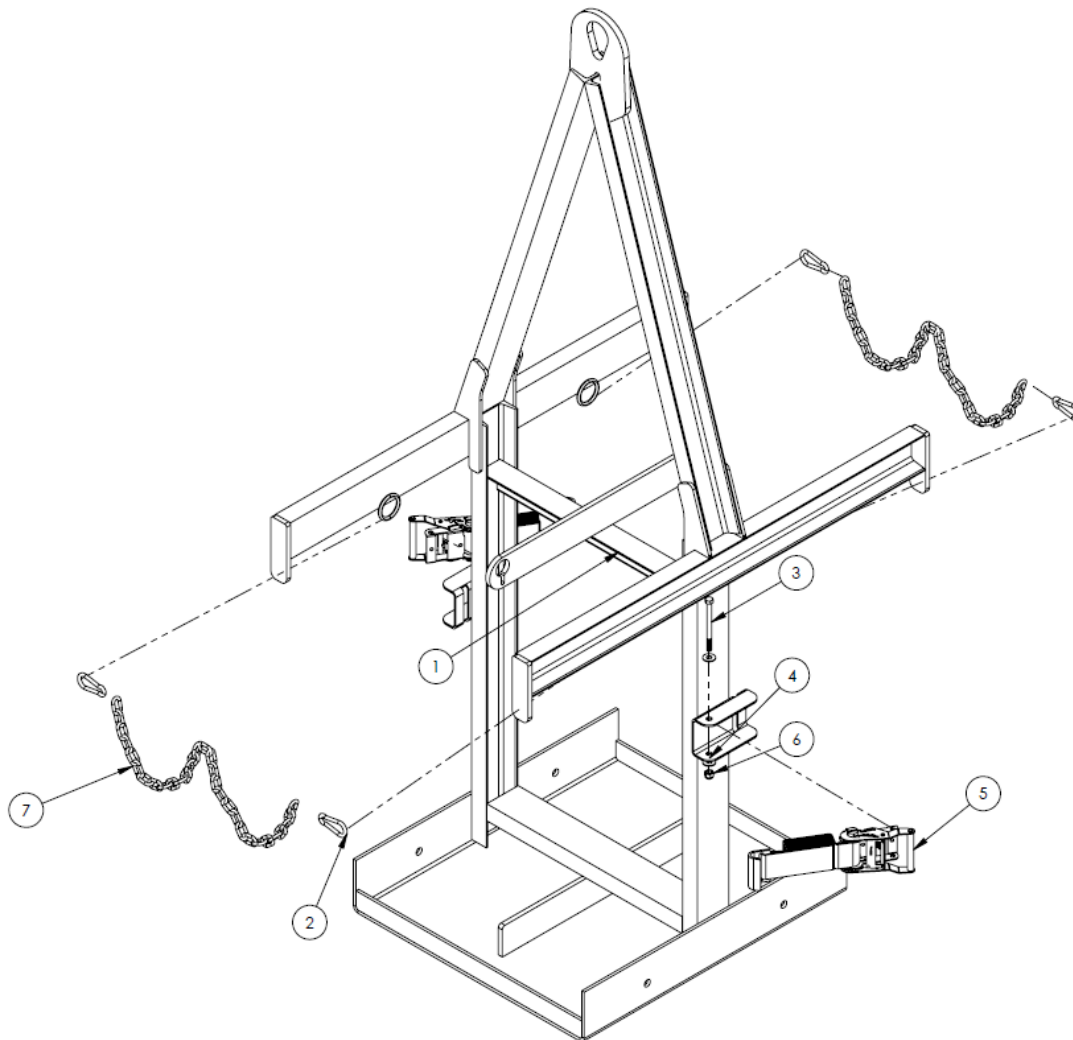

ITEM NO.	PART NO.	DESCRIPTION	QTY.
1	33-514-189	OVERHEAD LIFTING FRAME WELDMENT	1
	33-514-188	CYL-P-4-LUG	1
	33-514-187	CYL-P-6-LUG	1
2	08-145-008	1/4" SNAP HOOK	4
3	1111069	HEX CAP SCREW, GRADE 2, Z PLATED, 5/16"-18 X 4"	2
4	33006	FLAT WASHER, ZINC PLATED, USS, 5/16"	4
5	16-145-018	2" X 36" STRAP WITH RATCHET	2
6	37021	NYLON INSERT LOCK NUT, GRADE 2, ZINC FINISH, 5/16"-18	2
7	08-145-031	3/16" X 30" CHAIN (CYL-P-4-LUG)	2
	99-145-025	3/16" X 36" CHAIN (CYL-P-6-LUG)	2
	08-145-030	3/16" X 42" CHAIN (CYL-P-8-LUG)	2

## NATIONAL STANDARDS

This product is categorized as a “Below-the-Hook Lifting Device” (BTH lifters). [ASME standard B30.20](#) (the “Standard”) applies to BTH lifters. You **should** acquire a copy of the latest version of the Standard. Follow all use and maintenance/care instructions provided in the Standard as well as all other provisions for BTH owners and users. If content in this manual conflicts with any recommendations or mandatory provision(s) in the Standard, apply the provision(s) from the Standard. Vestil encourages you to immediately contact [Technical Service](#) if you discover any conflicts.

## USING THE LIFTER

NOTE: Numbers in parenthesis ( ) correspond to item numbers in the [EXPLODED VIEW](#) on p. 3.

The lifter has a bay for each cylinder. Put 1 cylinder in each bay. Bays can accommodate cylinder up to 9<sup>1</sup>/<sub>2</sub>” (24cm) in diameter. Each cylinder must be tall enough that its side wall touches the crossbar when loaded on to the lifter. To use the lifter to move cylinders, apply the following steps:

1. Move chains out of the way by disconnecting one of their snap hooks (2) from the frame.
2. Load cylinders onto the lifter: 1 cylinder per bay. Make sure that each cylinder rests firmly against the top and bottom crossbars. Load the lifter so that it balances when suspended.
3. Reattach the snap hook to the frame.
4. Locate the ratchet straps (5). There is 1 strap for each side of the lifter.
  - A. Release the ratchet to extend the straps. To release the ratchet:
    - i. Pull the release lever up (toward the handle).
    - ii. While holding up the release lever, pivot the handle as far from the ratchet base as it will travel (approximately 180 degrees).
    - iii. Pull the strap to unwind it from the spindle.
  - B. Secure the cylinders with the straps.
    - i. Wrap the strap around the outside of the cylinders.
    - ii. Attach the ratchet strap hook to the hook slot of the strap bracket.
    - iii. Pull the release lever up. Move the (ratchet) handle back towards the base and let go of the release lever.
    - iv. Move the handle back-and-forth to tighten the strap against the cylinders. The strap must firmly press all cylinders against the crossbar. No cylinder should be able to move with the strap in place. If cylinders of different diameters are loaded on the same side of the lifter, the strap might not adequately restrain the cylinder of smaller diameter. Confirm that all cylinders are secure before moving to the next step.
5. Attach a hoist hook to the lifting bale. Make sure that the hoist is centered above the bale. If the hoist is not properly centered, the lifter will swing when it lifts off of the ground. Avoid load swing!
6. Slowly make the hoist chain/cable taut. Once the chain/cable is taut, slowly and carefully raise the lifter off of the ground. Only raise the lifter as high as necessary. The lifter should balance when it is suspended, i.e. the bottom of the lifter should be horizontal and level. Return the lifter to the ground and redistribute the load to balance the lifter, if necessary.
7. Carefully move the loaded lifter. Keep the lifter in sight at all times. Do not leave the lifter while it is suspended. Always land the lifter and disconnect it from the hoist before leaving it.
8. Remove cylinders by releasing the ratchet straps (refer to Step 4A) and opening the chains.

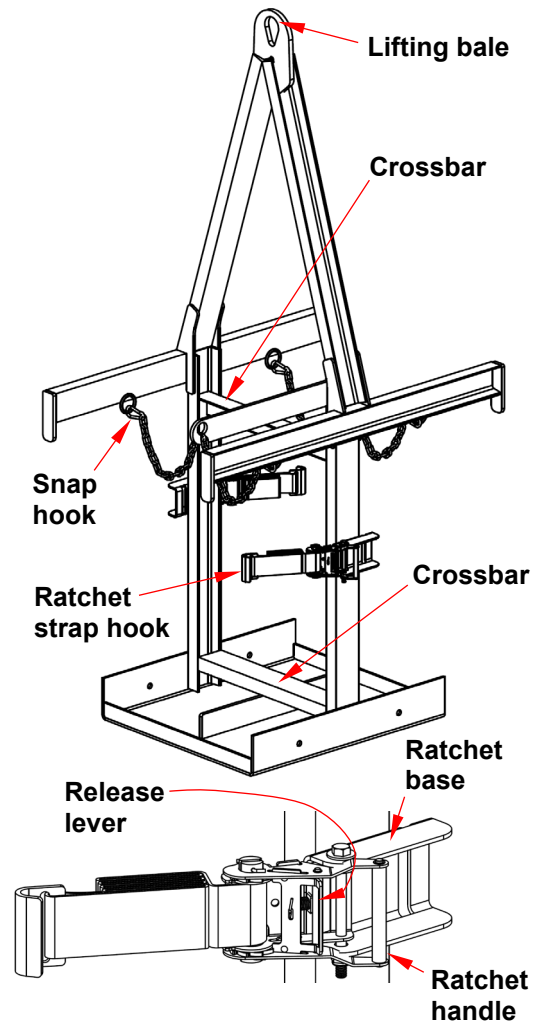

## RECORD OF SATISFACTORY CONDITION

Record the condition of the lifter before putting it into regular service. Measure the length and width of the lifting bale. Record your measurements. Thoroughly photograph the unit from multiple angles. Include close range photos of all labeling, the lifting bale, the base plate (floor), snap hooks and snap hook attachment points, ratchet straps and attachment hardware (pins, bolts, nuts, etc.), and welds. Collate all photographs and writings into a single file. Mark the file appropriately to identify it. This record is documentation of the lifter in satisfactory condition. Compare the results of all inspections to this record to determine whether the unit is in satisfactory condition. If the lifter is not in satisfactory condition, repair it before returning it to service. Purely cosmetic changes, like damaged paint/powdercoat, do not constitute changes from satisfactory condition. However, touchup paint should be applied to all affected areas as soon as cosmetic damage occurs to prevent rusting and corrosion. If left unaddressed, rusting/corrosion will alter the lifter from satisfactory condition and could make it unsafe to use.

## LOAD TESTS

After creating a [RECORD OF SATISFACTORY CONDITION](#) and before using the lifter for the first time, a qualified person should conduct a load test. The test load should be 125% of the rated load of the lifter. The rated load of all CYL-P-LUG lifters is 800 pounds (363.6kg), so the test load should be 1000 pounds (454.5kg). Raise the lifter until it is suspended. Return the lifter to the ground and unload it. Perform a [Monthly Inspection](#) as described in [INSPECTIONS AND MAINTENANCE](#) (below). The lifter must undergo load testing immediately after it is repaired, modified, or altered.

## INSPECTIONS AND MAINTENANCE

**NOTICE** Regular inspections and maintenance are essential. Always inspect and maintain this product in accordance with the instructions in this manual.

Inspection procedures are included in the most current revision of ASME B30.20. As stated above in the [NATIONAL STANDARDS](#) section, Vestil recommends that you acquire a copy of the most recent revision of this standard. Apply all use and maintenance/care instructions in the standard. Vestil also recommends that you contact your local occupational safety and health authority to determine if any laws, regulations, codes, ordinances, etc. apply inspection requirements to below-the-hook lifters.

Inspections and repairs should be performed by qualified persons. Compare the results of each inspection to the [RECORD OF SATISFACTORY CONDITION](#). Do not use the lifter unless all parts are in satisfactory condition. Replace all parts that are not in satisfactory condition before using the lifter again. **DON'T GUESS! If you have any questions about the condition of your lifter, contact the TECHNICAL SERVICE department.** The phone number is provided on the cover page of this manual. Never make temporary repairs of damaged or missing parts. Only use manufacturer-approved replacement parts to restore the lifter to satisfactory condition.

### **Every lift**

The operator of the lifter must inspect the lifter and cylinder surfaces before every lift. Check the lifter and all cylinders for dirt or other surface debris. Clean the surfaces.

**Monthly Inspections** – At least once per month a qualified person must perform the following inspections. Written reports should be prepared for every monthly inspection including inspections following [LOAD TESTS](#).

1. **Fasteners:** Examine hardware & fasteners, including but not limited to bolts, nuts, and pins. Replace damaged, worn, or corroded hardware.
2. **Frame elements:** Examine all frame elements for deformation, cracks, excessive wear, corrosion/rusting, and metal fatigue. Pay particular attention to the lifting bale. Measure its length and width. Compare the measurements to the measurements in your [RECORD](#). Examine the whole structure for severe rusting/metal erosion, rot, thinned regions. If rusting is purely superficial, remove the rust/corrosion with a steel bristle brush or steel wool. Clean the affected area and apply touchup paint. If rusting, rot, or thinning has weakened the material, contact technical service for advice.
3. **Snap hooks and chains:** Examine the chains and snap hooks. Hooks should not be bent, cracked, twisted, or otherwise deformed. Latches should automatically close. Chain links should not be damaged, e.g. bent, cracked, or stretched.



4. **Labels:** Check all labels. Labels are shown in the *LABELING DIAGRAM* (below). Replace labels that are missing, damaged, or not easily readable.

### LABELING DIAGRAM

The unit should be labeled as shown in the diagram. However, label content and location are subject to change so your product might not be labeled exactly as shown. Replace all labels that are damaged, missing, or not easily readable (e.g. faded). To order replacement labels, contact the technical service and parts department online at [http://www.vestilmfg.com/parts\\_info.htm](http://www.vestilmfg.com/parts_info.htm). Alternatively, you may request replacement parts and/or service by calling (260) 665-7586 and asking the operator to connect you to the Parts Department.

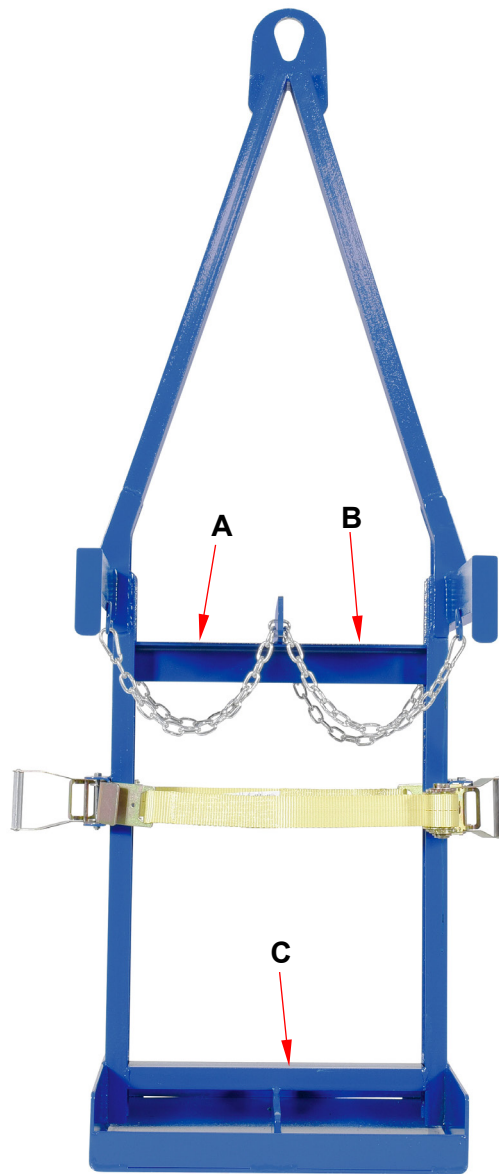

A: Label 675 (on top of upper crossbar)

⚠ WARNING	⚠ ADVERTENCIA
<ul style="list-style-type: none"> <li>• DO NOT exceed rated capacity</li> <li>• DO NOT use if damaged, malfunctioning, or missing parts</li> <li>• DO NOT lift people OR lift loads over people</li> <li>• DO NOT raise load higher than necessary</li> <li>• DO NOT leave a suspended load unattended</li> <li>• DO NOT use lifter unless you read and understand the owner's manual</li> <li>• DO NOT alter OR modify lifter</li> <li>• DO NOT remove OR obscure any label</li> <li>• STAY CLEAR of suspended loads</li> <li>• Secure load before using this device</li> </ul>	<ul style="list-style-type: none"> <li>• NO exceda la capacidad tasada</li> <li>• NO USE is las partes estan dañadas, no funcionan correctamente o faltan partes.</li> <li>• NO eleve al personal o eleve cargas sobre el personal</li> <li>• NO eleve la carga mas alto de lo necesario</li> <li>• NO deje desatendida una carga que este suspendida</li> <li>• NO use el elevador a no ser que haya leído y entendido las instrucciones del manual del propietario</li> <li>• NO altere o modifique el elevador</li> <li>• NO quite u oscurezca ninguna etiqueta</li> <li>• MANTENGASE alejado de las cargas suspendidas</li> <li>• Asegure la carga antes de usar este dispositivo</li> </ul>

B: Label 1000 (on top of upper crossbar)

Model No. _____	Serial No. _____
No. Modelo _____	No. Serie _____
Capacity _____ lbs.	Lifter Weight _____ lbs.
Capacidad _____ kgs.	Peso del Elevador _____ kgs.
BHT-1 Design Category: B BHT-1 Categoría de Diseño B	BHT-1 Service Category: 1 BHT-1 Categoría de Servicio: 1
<b>Read Owners Manual for product safety warnings</b> <b>Lea Manual de Proprietarios para advertencias de seguridad de producto</b>	
1000	

C: Label 286 (on top of lower crossbar)

⚠ WARNING	⚠ ADVERTENCIA
ONLY use to transport cylinders; DO NOT use as a storage device. Secure cylinder to dolly with all restraints For your safety, read all warnings on the cylinder	SOLO use para transportar cilindros NO USE como dispositivo de almacenaje Asegure el cilindro a la plataforma con todas las correas Para su seguridad, lea todas las advertencias en el cilindro

## LIMITED WARRANTY

Vestil Manufacturing Corporation (“Vestil”) warrants this product to be free of defects in material and workmanship during the warranty period. Our warranty obligation is to provide a replacement for a defective, original part covered by the warranty after we receive a proper request from the Warrantee (you) for warranty service.

### Who may request service?

Only a warrantee may request service. You are a warrantee if you purchased the product from Vestil or from an authorized distributor AND Vestil has been fully paid.

### Definition of “original part”?

An original part is a part used to make the product as shipped to the Warrantee.

### What is a “proper request”?

A request for warranty service is proper if Vestil receives: 1) a photocopy of the Customer Invoice that displays the shipping date; AND 2) a written request for warranty service including your name and phone number. Send requests by one of the following methods:

<u>US Mail</u>	<u>Fax</u>	<u>Email</u>
Vestil Manufacturing Corporation 2999 North Wayne Street, PO Box 507 Angola, IN 46703	(260) 665-1339 <u>Phone</u> (260) 665-7586	<a href="mailto:info@vestil.com">info@vestil.com</a> Enter “Warranty service request” in subject field.

In the written request, list the parts believed to be defective and include the address where replacements should be delivered. After Vestil receives your request for warranty service, an authorized representative will contact you to determine whether your claim is covered by the warranty. Before providing warranty service, Vestil will require you to send the entire product, or just the defective part (or parts), to its facility in Angola, IN.

### What is covered under the warranty?

The warranty covers defects in the following original, dynamic parts: motors, hydraulic pumps, motor controllers, and cylinders. It also covers defects in original parts that wear under normal usage conditions (“wearing parts”), such as bearings, hoses, wheels, seals, brushes, and batteries.

### How long is the warranty period?

The warranty period for original dynamic components is 90 days. For wearing parts, the warranty period is 90 days. Both warranty periods begin on the date Vestil ships the product to the Warrantee. If the product was purchased from an authorized distributor, the periods begin when the distributor ships the product. Vestil may, at its sole discretion, extend a warranty period for products shipped from authorized distributors by up to 30 days to account for shipping time.

### If a defective part is covered by the warranty, what will Vestil do to correct the problem?

Vestil will provide an appropriate replacement for any *covered* part. An authorized representative of Vestil will contact you to discuss your claim.

### What is not covered by the warranty?

The Warrantee (you) are responsible for paying labor costs and freight costs to return the product to Vestil for warranty service.

### Events that automatically void this Limited Warranty.

- Misuse;
- Negligent assembly, installation, operation or repair;
- Installation/use in corrosive environments;
- Inadequate or improper maintenance;
- Damage sustained during shipping;
- Collisions or other accidents that damage the product;
- Unauthorized modifications: Do not modify the product IN ANY WAY without first receiving written authorization from Vestil.

### Do any other warranties apply to the product?

Vestil Manufacturing Corp. makes no other express warranties. All implied warranties are disclaimed to the extent allowed by law. Any implied warranty not disclaimed is limited in scope to the terms of this Limited Warranty. Vestil makes no warranty or representation that this product complies with any state or local design, performance, or safety code or standard. Noncompliance with any such code or standard is not a defect in material or workmanship.