



Sno-Thro[®]

Operator's Manual
Manuel du Utilisateur

ARIENS
THE KING OF SNOW

Professional 21

Models

938024 – SSR

(SN 000101 +)

938025 – SSRC

(SN 000101 +)

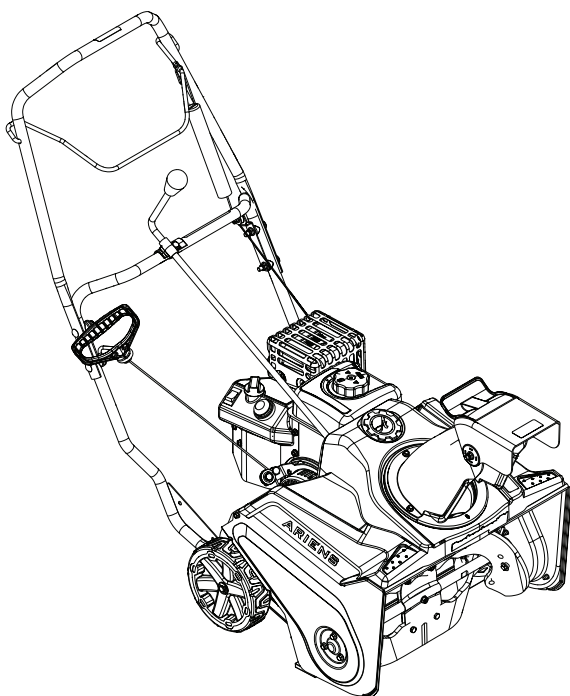

EN ENGLISH

FR FRANÇAIS

05147700 • 7/17
Printed in USA

TABLE OF CONTENTS

WELCOME	1	Long Term Storage	18
SAFETY	2	Start-of-Season Fuel Preparation	18
Practices & Laws	2	ACCESSORIES	18
Emission Control System	2	TROUBLESHOOTING	19
Required Operator Training	2	SPECIFICATIONS	20
Safety Alert Symbol	2	WARRANTY	21
Signal Words	2		
Safety Decals	3		
Safety Rules	4		
CONTROLS & FEATURES	8		
Engine Switch	9		
Choke Control Knob	9		
Fuel Valve	9		
Primer Bulb	9		
Hour Meter	9		
Auger Control Lever	9		
Discharge Chute Handle	9		
Discharge Chute Rotation Lever	10		
Discharge Chute Deflector Lever	10		
BEFORE OPERATION	10		
Check Engine Oil	10		
OPERATION	11		
Emergency Stopping	11		
Start The Engine	11		
Operate Unit	11		
Stop The Engine	12		
Transporting Unit	12		
For Best Performance	12		
MAINTENANCE	13		
Maintenance Schedule	13		
Service Parts	13		
Clean Unit	13		
Check Engine Oil	13		
Change Engine Oil	13		
Check Fasteners	13		
Check Deflector Resistance	13		
Check Auger Paddle Wear	14		
Check Scraper Blade Wear	14		
Check Belt Wear	14		
SERVICE & ADJUSTMENTS	14		
Replace Auger Paddles	14		
Adjust Auger Cable	15		
Replace Drive Belt	16		
Replace Scraper Blade	17		
STORAGE	18		
Short Term Storage	18		

WELCOME

Congratulations on your purchase and welcome to the Ariens family! Every machine in the Ariens lineup is designed for long-lasting and unsurpassed performance. We are confident your machine will be part of your family for many years to come.

Have Questions or Need Assistance?
ariensstore.com • arienscushelp.com

A parts manual for your unit is available for free download or purchase at ariens.com.

PRODUCT REGISTRATION

You or the dealer you purchased the unit from must register the product at the time of purchase. Know the model and serial numbers of your unit and register online at ariens.com or return the registration card to Ariens Company. See Figure 1 for label location.

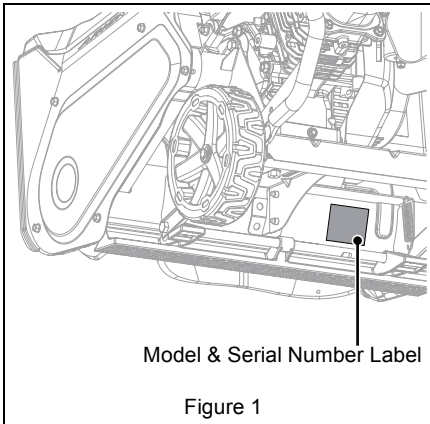

Record model number here.

Record serial number here.

MANUALS

Before operating or servicing the unit, carefully and completely read the manuals provided with the unit. They contain safety instructions and important information about unit controls.

The engine on this unit is covered by a separate manual. Refer to the engine manual for engine service recommendations. Contact the engine manufacturer for a replacement manual if necessary.

Your dealer must review important information in this manual with you before or upon delivery of the unit. It is your responsibility to read and understand all safety precautions and instructions in the manuals. If you do not understand or have difficulty following the instructions, contact your Ariens dealer for assistance. To locate your nearest Ariens dealer, go to ariensstore.com.

DISCLAIMER

Ariens reserves the right to discontinue, make changes to, and add improvements upon its products at any time without public notice or obligation. The descriptions and specifications contained in this manual were in effect at printing. Equipment described in this manual may be optional. Some illustrations may not be applicable to your unit.

SAFETY

Read these safety rules and follow them closely. Failure to follow these rules could lead to loss of control of unit, severe personal injury or death to you or bystanders, or result in damage to property or the machine.

PRACTICES & LAWS

Practice usual and customary safe working precautions. Learn applicable rules and laws in your area. Always follow the practices set forth in this manual.

EMISSION CONTROL SYSTEM

This equipment and/or its engine may include exhaust and evaporative emissions control system components required to meet U.S. Environmental Protection Agency (EPA) and/or California Air Resources Board (CARB) regulations. Tampering with emission controls and components by unauthorized personnel may result in severe fines or penalties. Emission controls and components can only be adjusted by an Ariens Company dealer or an authorized engine manufacturer's service center. Contact your Ariens Company Equipment Retailer concerning emission controls and component questions.

REQUIRED OPERATOR TRAINING



Read and understand the Operator's Manual and decals on the unit. This information is for your safety and the proper use of your equipment. Failure to follow these

instructions and warnings may cause death or serious injury. If you have purchased this product from an Ariens dealer, the dealer can provide you with training.

Familiarize yourself and any other operators with all controls and the safe use of the features of this unit. If you loan, rent or sell this product to others, provide them with all manuals.

If you have any questions, please call our customer support line at 920-756-4688 or contact us at www.ariens.com. Do not use this equipment if, after reading the Operator's Manual and the on-board decals, you have any questions about the safe use of this product.



WARNING: AVOID INJURY. This snow thrower is capable of crushing or amputating body parts. Failure to observe the safety instructions in the manuals and on decals could result in serious injury or death.

ALWAYS disengage auger, stop unit and engine and allow moving parts to stop before leaving operator's position.

SAFETY ALERT SYMBOL



This is the safety alert symbol. It means:

- **ATTENTION!**
- **YOUR SAFETY IS INVOLVED!**

When you see this symbol:

- **BECOME ALERT!**
- **OBEY THE MESSAGE!**

SIGNAL WORDS

The safety alert symbol above and signal words below are used on decals and in this manual. Read and understand all safety messages.

1. Danger



DANGER: Indicates an **IMMINENTLY HAZARDOUS SITUATION!** If not avoided, **WILL RESULT** in death or serious injury.

2. Warning



WARNING: Indicates a **POTENTIALLY HAZARDOUS SITUATION!** If not avoided, **COULD RESULT** in death or serious injury.

3. Caution



CAUTION: Indicates a **POTENTIALLY HAZARDOUS SITUATION!** If not avoided, **MAY RESULT** in minor or moderate injury. It may also be used to alert against unsafe practices.

4. Notice

NOTICE: Indicates information or procedures that are considered important but not hazard related. If not followed, property damage could result.

5. Important

IMPORTANT: Indicates general reference information worthy of special attention.

SAFETY DECALS

The safety decals on your machine are visual reminders of the important safety information in this manual. All messages on your unit must be fully understood and carefully followed. Safety decals on the machine are explained below.

Always replace missing or damaged safety decals. Replacement decal information is in the parts manual for your machine. Decals can be ordered from your dealer.

See Figure 2 for safety decal locations.

Safety Decal Locations

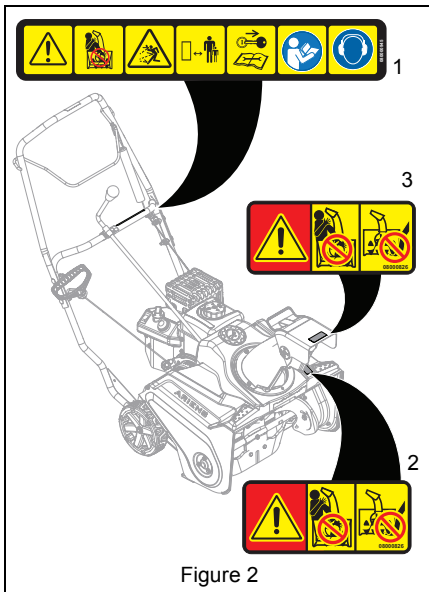

Safety Decal Descriptions

1. DANGER!



Danger!



Only use clean-out tool to clear blockages. NEVER use your hands.



NEVER direct discharge towards persons or property that may be injured or damaged by thrown objects.



Keep people away from unit while operating. Keep children out of work area and under watchful care of a responsible adult.



Stop engine and read manual before making any repairs or adjustments.



Read operator's manual.



Wear appropriate hearing protection.

2. DANGER!



Danger!



ROTATING PARTS.

Keep clear of auger while engine is running.

- Read Operator's Manual.
- Allow operation only by properly trained adult, never children.
- Stop engine prior to leaving the operator's position for any reason.
- Keep all controls, guards and safety devices properly serviced and functional.
- Never direct discharge towards persons or property that may be injured or damaged by thrown objects.



3. DANGER!



Danger!



ROTATING PARTS! ONLY use clean-out tool to clear blockages. **NEVER** use your hands. High speed auger/impeller rotates below discharge opening. Wait for all moving parts to stop before removing clogs or servicing.



SAFETY RULES

The following safety instructions are based on the B71.3 specifications of the American National Standards Institute in effect at the time of production.

Training

Read, understand and follow all instructions on the machine and in the manual(s) before operating this unit. Be thoroughly familiar with the controls and the proper use of the equipment. Know how to stop the unit and disengage the controls quickly.

Never allow children to operate the equipment. Never allow adults to operate the equipment without proper instruction, including actual operation.

Keep the area of operation clear of all persons, particularly small children. Keep children under watchful care of a responsible adult. Be alert and shut off unit if children enter area.

Exercise caution to avoid slipping or falling, especially when operating the snow thrower in reverse.

Always remove key and/or wire from spark plug before assembly, maintenance or service. Unintentional engine start up can cause death or serious injury.

Complete a walk-around inspection of the unit to understand the unit, your work area, and all safety decals.

Preparation

Always check overhead and side clearances carefully before operation.

Always be aware of traffic when operating along streets or curbs.

Thoroughly inspect the area where the equipment is to be used and remove all pets, doormats, sleds, boards, toys, wires, debris and other foreign objects.

Disengage the auger control lever before starting the engine (motor).

<p>Handle fuel with care; it is highly flammable.</p> <ul style="list-style-type: none"> • Use an approved fuel container. • Never add fuel to a running engine or hot engine. • Fill fuel tank outdoors with extreme care. Never fill fuel tank indoors. • Never fill containers inside a vehicle or on a truck or trailer bed with a plastic liner. Always place containers on the ground, away from your vehicle, before filling. • When practical, remove gas-powered equipment from the truck or trailer and refuel it on the ground. If this is not possible, then refuel such equipment on a trailer with a portable container, rather than from a gasoline dispenser nozzle. • Keep the nozzle in contact with the rim of the fuel tank or container opening at all times, until refueling is complete. Do not use a nozzle lock-open device. • Replace gasoline cap securely and wipe up spilled fuel. • If fuel is spilled on clothing, change clothing immediately.
<p>Never attempt to make any adjustments while the engine (motor) is running (except when specifically recommended by manufacturer).</p>
<p>Always allow unit and engine to adjust to outdoor temperature before clearing snow.</p>

<p>Operation</p>
<p>Never leave a running unit unattended. Always shut off engine before leaving unit.</p>
<p>Do not put hands or feet near or under rotating parts. Keep clear of the discharge opening at all times.</p>
<p>Moving and/or rotating parts can cut off body parts such as fingers or a hand. Always keep hands, feet and clothing away from all rotating parts during operation.</p>
<p>Always keep hands away from all pinch points.</p>
<p>Do not touch unit parts which might be hot from operation. Allow parts to cool before attempting to maintain, adjust or service.</p>
<p>Check for weak spots on docks, ramps or floors. Avoid uneven work areas and rough terrain. Stay alert for hidden hazards.</p>
<p>Exercise extreme caution when operating on or crossing gravel drives, walks or roads. Stay alert for hidden hazards or traffic.</p>

<p>After striking a foreign object, stop the engine (motor), remove the wire from the spark plug, thoroughly inspect the snow thrower for any damage, and repair the damage before restarting and operating the snow thrower.</p>
<p>If the unit should start to vibrate abnormally, stop the engine (motor) and check immediately for the cause.</p>
<p>Stop the engine (motor) whenever you leave the operating position, before unclogging the auger/impeller housing or discharge chute, and when making any repairs, adjustments or inspections.</p>
<p>When cleaning, repairing or inspecting the snow thrower, make certain the auger/impeller and all moving parts have stopped. Disconnect the spark plug wire and keep the wire away from the plug to prevent someone from accidentally starting the machine.</p>
<p>Do not run the engine (motor) indoors. Open the outside doors; exhaust fumes are dangerous.</p>
<p>Never operate the snow thrower without proper guards and other safety protective devices in place.</p>
<p>Thrown objects can cause injury. Never direct the discharge toward people or areas where property damage can occur from thrown objects. Keep children and others away.</p>
<p>Do not overload the machine capacity by attempting to clear snow at too fast a rate. Slow down and turn corners slowly.</p>
<p>Never operate the machine at high transport speeds on slippery surfaces. Look behind and use care when backing.</p>
<p>Do not operate in reverse unless absolutely necessary. Always back up slowly and look down and behind before and while backing.</p>
<p>Do not carry passengers.</p>
<p>Disengage attachment drive when traveling from one work area to another.</p>
<p>Disengage power to the auger/impeller when snow thrower is transported or not in use.</p>
<p>Use only attachments and accessories approved by the manufacturer of the snow thrower (such as wheel weights, counterweights or cabs).</p>

This product is equipped with an internal combustion type engine. Do not use unit on or near any unimproved, forest-covered or brush-covered land unless exhaust system is equipped with a spark arrester meeting applicable local, state or federal laws. A spark arrester, if it is used, must be maintained in effective working order by operator.

Never operate the snow thrower without good visibility or light. Falling snow, fog, etc. can reduce vision and cause an accident.

Never operate unit after or during the use of medication, drugs or alcohol. Safe operation requires complete and unimpaired attention at all times.

Never allow anyone to operate this unit when their alertness or coordination is impaired.

Do not throw snow any higher than necessary.

Clearing a Clogged Discharge Chute

Hand contact with the rotating auger/impeller inside the discharge chute is the most common cause of injury associated with snow throwers. Never use your hand to clean out the discharge chute.

To clear the chute:

1. SHUT THE ENGINE OFF!
2. Wait 10 seconds to be sure the auger/impeller blades have stopped rotating.
3. Always use a clean-out tool, not your hands.

Maintenance and Storage

Secure unit so it will not tip over during maintenance.

Before cleaning, removing clogs or making any inspections, repairs, etc., disengage auger control lever, stop unit and engine, allow moving parts to stop and hot parts to cool.

Make sure the equipment is in safe working condition. Check hardware at frequent intervals for proper tightness. If components are worn or damaged, replace with manufacturer's recommended parts.

Do not change engine governor settings or over-speed engine.

Adjust and service as required. All motion of auger/impeller must stop quickly when auger control lever is released.

Always maintain unit in safe operating condition. Damaged or worn out muffler can cause fire or explosion.

Keep unit free of ice or other debris. Clean up oil or fuel spills.

Always keep protective structures, guards, and panels in good repair, in place and securely fastened. Never modify or remove safety devices.

Never store the machine with fuel in the fuel tank inside a building where ignition sources are present such as hot water heaters, space heaters or clothes dryers. Allow the engine to cool before storing in any enclosure or covering the unit.

Always refer to operator's manual for important details if the snow thrower is to be stored for an extended period.

Maintain or replace safety and instruction labels as necessary.

Run the machine a few minutes after throwing snow to prevent freeze-up of the auger/impeller.

Personal Protection

Do not operate the equipment without wearing adequate winter garments. Avoid loose fitting clothing that can get caught in moving parts. Wear footwear that will improve footing on slippery surfaces.

Wear adequate safety gear, including safety glasses with side shields, and protective gloves.

Do not wear loose clothing or jewelry, and tie back hair that may get caught in rotating parts.

Protect eyes, face and head from objects that may be thrown from unit. Wear appropriate hearing protection.

Slope Operation

Operate the snow thrower on level surfaces. Stay off slopes and slippery surfaces.

Do not clear snow across the face of slopes; go up and down. Exercise extreme caution when operating on slopes. Do not attempt to clear steep slopes.

Use a slow speed to avoid stops or shifts on slopes. Avoid starting or stopping on a slope. Do not park unit on a slope unless absolutely necessary. When parking on a slope always block the wheels.

Do not operate near drop-offs, ditches, or embankments. Unit can suddenly turn over if a wheel is over the edge of a cliff or ditch, or if an edge caves in.

Fuel

Do not run engine in an enclosed area. Always provide good ventilation. Fumes from engine exhaust can cause injury or death.

Fuel is highly flammable and its vapors are explosive. Handle with care. Use only an approved gasoline container with an appropriately sized dispensing spout.

No smoking, sparks or flames. Always allow engine to cool before servicing.

Never fill fuel tank when engine is running or hot from operation.

Never fill or drain fuel tank indoors.

Replace fuel cap securely and clean up spilled fuel.

Properly remove fuel before tipping unit up onto housing, so no spills will occur.

Towing/Transporting

Always shut off engine and close fuel shut-off valve or drain fuel when transporting unit on a truck or trailer.

Use extra care when loading or unloading unit onto trailer or truck. Secure unit chassis to transport vehicle. Never secure from rods or linkages that could be damaged. Do not transport machine while engine is running.

Accessories

Use only Ariens Company-approved attachments that are appropriate to your use and can be used safely in your application.

CONTROLS & FEATURES

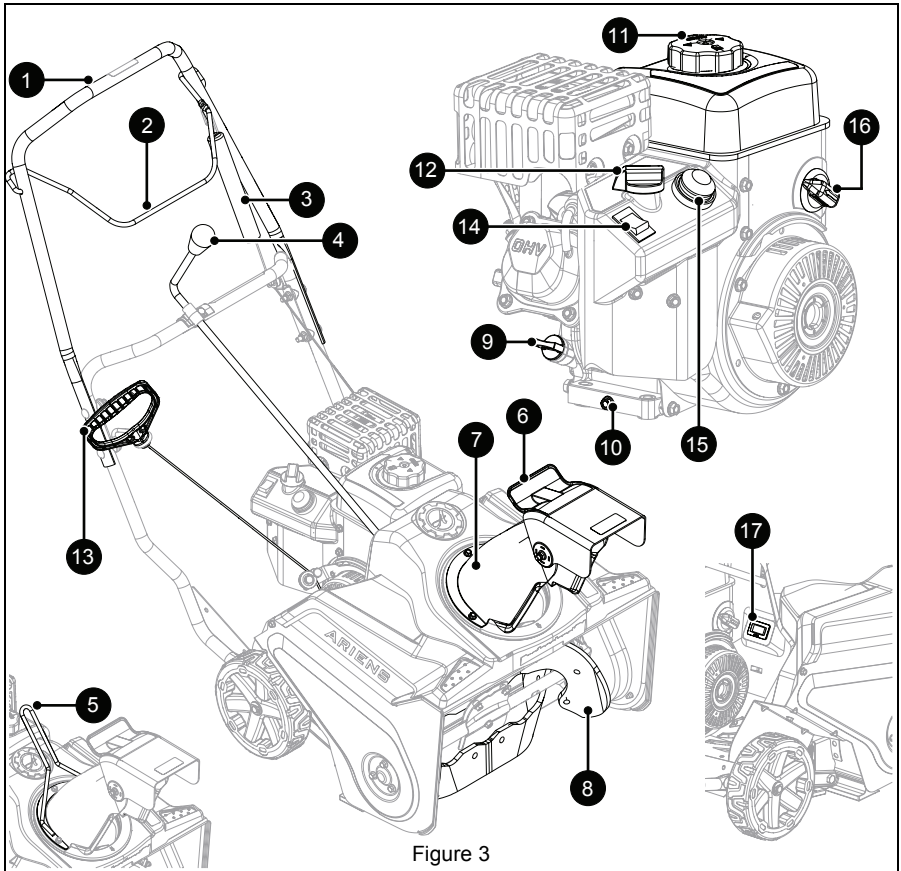

Figure 3

- | | |
|---|---------------------------|
| 1. Handlebar | 9. Oil Fill Port |
| 2. Auger Control Lever | 10. Oil Drain |
| 3. Auger Control Cable Adjustment Plate | 11. Fuel Tank & Cap |
| 4. Discharge Chute Rotation Lever (Model 938025) | 12. Choke Control Knob |
| 5. Discharge Chute Rotation Handle (Model 938024) | 13. Recoil Starter Handle |
| 6. Discharge Chute Deflector Lever | 14. Engine Switch |
| 7. Discharge Chute | 15. Primer Bulb |
| 8. Auger Paddle | 16. Fuel Valve |
| | 17. Hour Meter |



WARNING: AVOID INJURY. Read and understand the *Safety* section before proceeding.

See Figure 3 for all controls and features locations.

ENGINE SWITCH

See Figure 4.

Controls power to the engine. Engine switch must be in the run position to start and operate the engine. Engine will stop and will not start when switch is in the stop position.

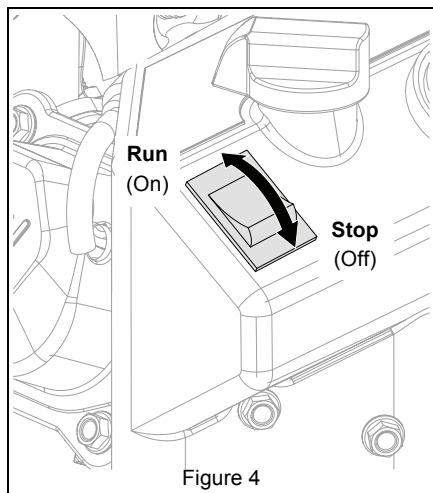

Figure 4

CHOKE CONTROL KNOB

See Figure 5.

Restricts air intake for easier starting on cold engines.

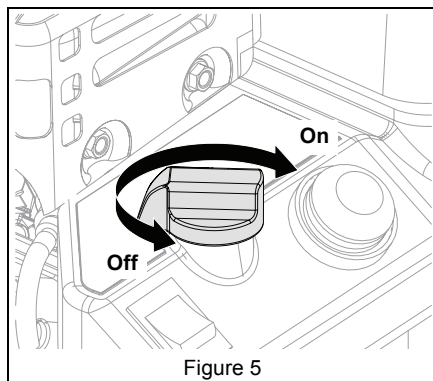

Figure 5

FUEL VALVE

See Figure 6.

Controls fuel flow to the engine.

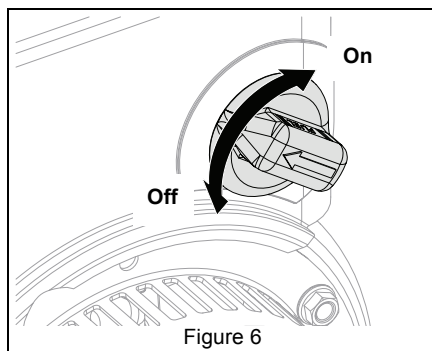

Figure 6

PRIMER BULB

Adds fuel to engine for easier starting on cold engines.

HOUR METER

Measures and displays engine runtime.

AUGER CONTROL LEVER

Engages and disengages auger paddle rotation. Pulls unit forward when engaged.

DISCHARGE CHUTE HANDLE

Model 938024

See Figure 7.

Rotates discharge chute left or right to control direction of snow discharge.

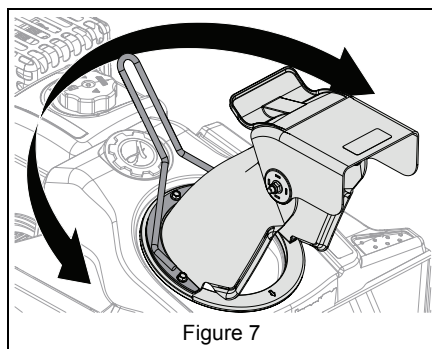

Figure 7

DISCHARGE CHUTE ROTATION LEVER

Model 938025

See Figure 8.

Rotates discharge chute left or right to control snow discharge.

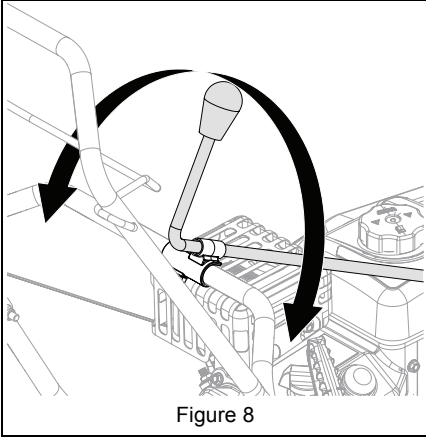

Figure 8

DISCHARGE CHUTE DEFLECTOR LEVER

See Figure 9.

Moves discharge deflector up or down to control height of snow discharge.

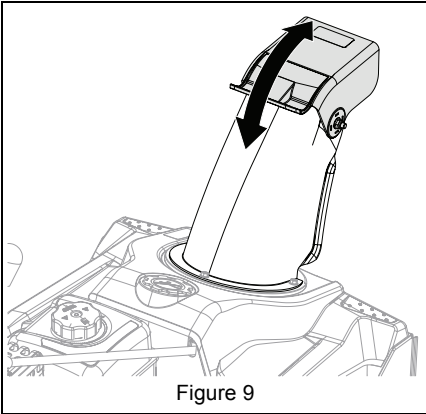

Figure 9

BEFORE OPERATION



WARNING: AVOID INJURY. Read and understand the *Safety* section before proceeding.

IMPORTANT: All references to left, right, front or rear are given from the perspective of operator in operator's position, facing the direction of forward travel.

1. Know how to stop in an emergency. See *Emergency Stopping* on page 11.
2. Check for frozen components.
3. Check fuel level and add fuel if needed.

IMPORTANT: Use fresh unleaded fuel with an octane rating of at least 87. DO NOT use E85 blended fuels; the engine is not E20 / E30 / E85 compatible. The maximum recommended ethanol content is 10%. Ariens recommends using a quality fuel stabilizer in all fuel. See *Short Term Storage* on page 18.

4. Check engine oil level and add oil if needed. See *Check Engine Oil* on page 10.
5. Check function of all controls.

CHECK ENGINE OIL

1. Stop engine and wait for all moving parts to stop and for hot parts to cool.
2. Remove dipstick from oil fill port.
3. Check engine oil level and add oil if needed. Refer to engine manual.
4. Reinstall dipstick and tighten.

IMPORTANT: Clean up any spilled oil.

OPERATION



WARNING: AVOID INJURY. Read and understand the *Safety* section before proceeding.

EMERGENCY STOPPING

1. Release auger control lever.
2. Push engine switch to the stop position.
3. Wait for all moving parts to stop before leaving operator's position.

START THE ENGINE

1. Position discharge chute in a safe direction. See *Position Discharge Chute* on page 11.
2. Turn fuel valve to the on position.
3. Push engine switch to run position.
4. *Cold Engines Only:* Turn choke control knob to on position.
5. *Cold Engines Only:* Push primer bulb twice.
6. Pull recoil starter handle.
 - a. Grasp handle and pull rope out slowly until it pulls harder.
 - b. Pull handle firmly and quickly with a rapid, continuous full-arm stroke. Repeat until engine starts. If engine does not start, see *Troubleshooting* on page 19.
 - c. Let handle rewind slowly after engine starts. **DO NOT** let handle snap back against handlebar.
7. Gradually turn choke off as engine warms.

OPERATE UNIT

1. Rotate discharge chute and move deflector to desired positions. See *Position Discharge Chute* on page 11.

NOTICE: On some surfaces, auger paddle rotation may leave residual paddle material. This usually washes off after rain showers.

2. Engage auger control lever to clear snow and move unit forward. Release bar to stop augers and unit. See Figure 10.

IMPORTANT: If unit does not propel itself forward in heavy snow or on slippery surfaces, push forward on the handlebar. Allow unit to work at its own pace.

IMPORTANT: Disengage auger when traveling between work areas.

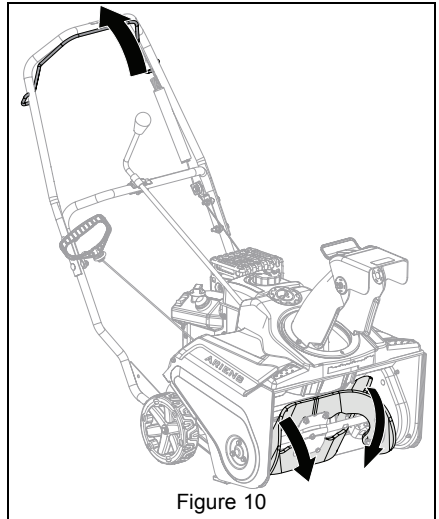

Figure 10

3. Move handlebar left and right to steer unit.
4. Reposition discharge chute and deflector as necessary.

Position Discharge Chute

IMPORTANT: Always throw snow in a safe direction, away from people and windows.

NOTICE: If chute becomes frozen and does not turn correctly, move unit into warm area until controls are unfrozen.

See Figure 11.

1. Release auger control lever.
2. *Model 938025:* Move discharge chute rotation lever left or right to rotate chute. *Model 938024:* Move discharge chute rotation handle left or right to rotate chute.
3. Move deflector lever up or down to control discharge distance.

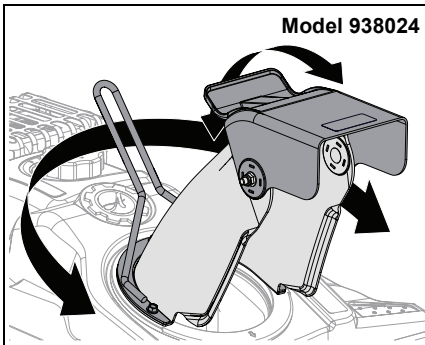

Model 938024

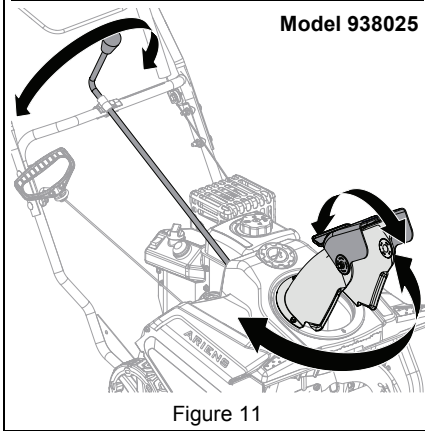

Model 938025

Figure 11

TRANSPORTING UNIT

1. Stop engine and wait for all moving parts to stop and for hot parts to cool.

NOTICE: Use extra care when loading or unloading onto truck or trailer. DO NOT lift using discharge chute handle.

2. Secure unit chassis to transport vehicle.

NOTICE: Never secure unit from rods or linkages that could be damaged.

FOR BEST PERFORMANCE

- For complete snow removal, walk slowly and slightly overlap each path previously taken.
- Position discharge chute downwind when possible.
- Do not allow unit to ingest gravel and rocks. Push handlebar down slightly over loose surfaces to avoid ingesting debris.
- Inspect auger before each use and remove any accumulation / debris.
- Check oil level before each use.
- Clean unit after each use. See *Clean Unit* on page 13.

Clear a Clogged Discharge Chute

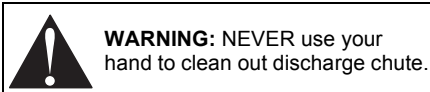

1. Stop engine and wait for all moving parts to stop and for hot parts to cool.
2. Use a tool to clear the clog. See *Troubleshooting* on page 19.

STOP THE ENGINE

1. Operate the auger momentarily to remove loose or melting snow from unit to help prevent moving parts from freezing.
2. Release auger control lever.
3. Push engine switch to off position.
4. Turn fuel valve to the off position.

MAINTENANCE



WARNING: AVOID INJURY. Read and understand the *Safety* section before proceeding.

Proper maintenance can prolong the life of your unit. The *Maintenance Schedule on Page 13* shows the recommended service schedule.

Your Ariens dealer can provide service and adjustments to keep your unit operating at peak efficiency. Contact an authorized engine manufacturer's service center for engine service.

More frequent service may be required due to working conditions.

See the maintenance instructions in the Engine Manual for additional information.

MAINTENANCE SCHEDULE

Service Performed	Each Use	Every 10 hrs.	As Needed	Annually
Clean Unit	•			
Check Engine Oil*	•			
Check Fasteners	•			
Check Auger Paddle Wear	•			•
Check Scraper Blade Wear	•			•
Check Belt Wear		•		•
Replace Scraper Blade**			•	
Change Engine Oil*			•	
Replace Auger Paddles			•	

*Refer to engine manual for instructions.

**See *Check Scraper Blade Wear* on page 14.

SERVICE PARTS

See your Ariens dealer to purchase service parts for your unit.

Description	Part No.
Fuel Stabilizer – 118 ml (4 oz)	
• Except Canada	04730400
• Canada Only	04742500
Spark Plug	20001246
Ariens 5W-30 Engine Oil	
• 473 ml (16 oz)	00091000
• 946 ml (32 oz)	00067600

Description	Part No.
Auger Cable	06900533
Auger Belt	07200627
Auger Paddle Replacement Kit	73801200
Scraper Blade Replacement Kit	53804100
Pawl Arm Replacement Kit	53803800

CLEAN UNIT

1. Wash salt and other corrosive ice-melting agent residue from unit with mild soap and low-pressure water.

NOTICE: NEVER spray unit with high-pressure water.

2. Remove snow and debris with a soft-bristled brush. DO NOT use harsh abrasives or cleaners.

CHECK ENGINE OIL

See *Check Engine Oil* on page 10.

CHANGE ENGINE OIL

Refer to engine manual.

CHECK FASTENERS

Check for loose or missing hardware.

CHECK DEFLECTOR RESISTANCE

See Figure 12.

If discharge chute deflector moves up and down too easily, tighten deflector hardware slightly to increase resistance. DO NOT overtighten.

IMPORTANT: Use an Allen wrench to hold hardware in place and tighten hardware on both sides of deflector equally.

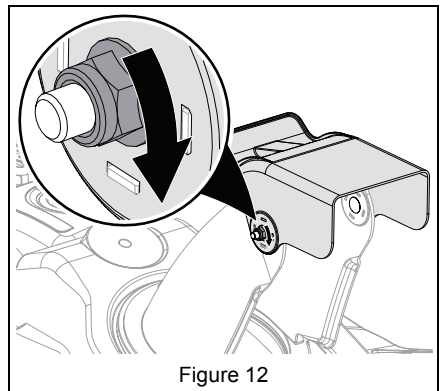
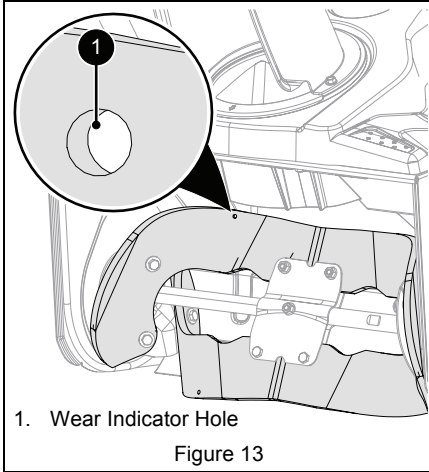

Figure 12

CHECK AUGER PADDLE WEAR

See Figure 13.

Check that paddles have not worn past wear indicator holes. Replace auger paddles when paddles have worn completely through wear indicator holes. See *Replace Auger Paddles* on page 14.



CHECK SCRAPER BLADE WEAR

Replace scraper blade if damaged, completely worn through, or with every other paddle replacement. See *Maintenance Schedule* on page 13.

NOTICE: DO NOT allow scraper blade to wear down too far or auger housing will become damaged. See *Replace Scraper Blade* on page 17.

CHECK BELT WEAR

Adjust auger cable to compensate for belt wear. If auger cable has been adjusted for maximum tension and auger stops or stutters when auger control lever is engaged, belt may need replacement. See *Adjust Auger Cable* on page 15 and *Replace Drive Belt on Page 16*.

SERVICE & ADJUSTMENTS



WARNING: AVOID INJURY. Read and understand the *Safety* section before proceeding.

IMPORTANT: All references to left, right, front or rear are given from the perspective of operator in operator's position, facing the direction of forward travel.

REPLACE AUGER PADDLES

Replace auger paddles when paddles have worn completely through wear indicator holes. See Figure 13.

IMPORTANT: ALWAYS replace paddles in pairs. DO NOT replace only one paddle.

Remove Auger Paddles

1. Stop engine and wait for all moving parts to stop and for hot parts to cool.
2. Disconnect spark plug wire and turn fuel valve to off position.
3. Tip unit back onto handlebar bend.

See Figure 14.

NOTICE: DO NOT tip beyond handlebar bend or oil may leak from engine.

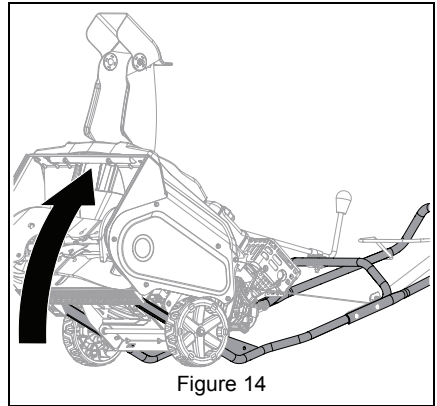

See Figure 15.

4. Remove hardware retaining paddles to center plate and side plates. Discard all parts.

IMPORTANT: DO NOT remove center plate.

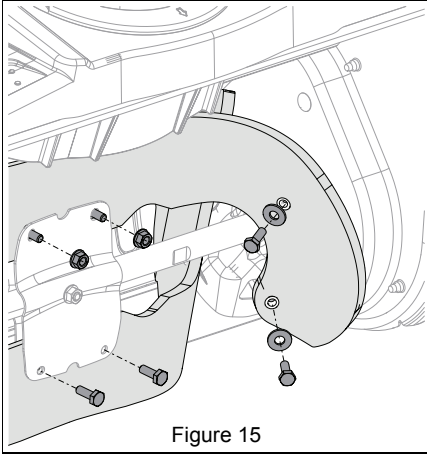

Figure 15

Install Auger Paddles

1. Install spacers into paddle holes. See Figure 16.

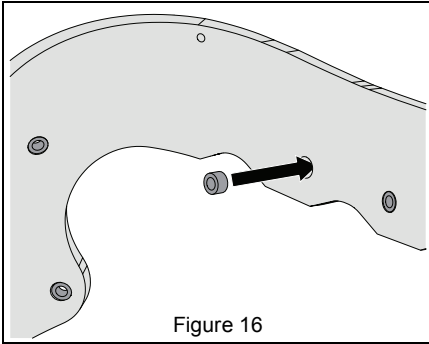

Figure 16

See Figure 17.

IMPORTANT: Install new paddles so wear indicator holes are positioned on the right side of unit.

2. Secure each paddle to side plates with four hex bolts, four flat steel washers and four flange nuts.
3. Secure each paddle to center plate with two hex bolts and two flange nuts.
4. Torque paddle hardware to $5.6 \text{ N}\cdot\text{m} - 10.2 \text{ N}\cdot\text{m}$ (50 lb-in – 90 lb-in). DO NOT overtighten.

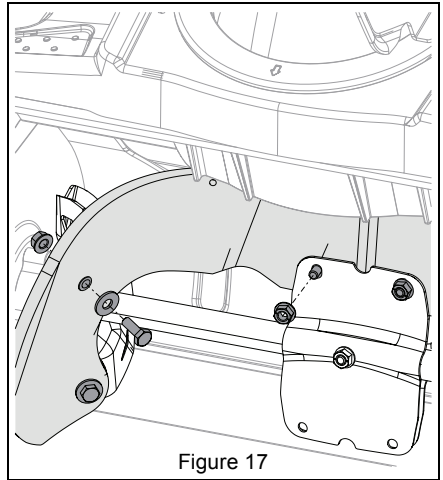

Figure 17

5. Rotate auger paddles by hand to ensure paddles are secure and do not interfere with housing.
6. Return unit to upright position.
7. Remove slack from auger cable. See *Adjust Auger Cable* on page 15.
8. Reconnect spark plug wire and turn fuel valve to the on position.

ADJUST AUGER CABLE

See Figure 18.

1. Stop engine and wait for all moving parts to stop and for hot parts to cool.
2. Move plastic sleeve up to auger control lever.
3. Remove cable end from adjustment bracket.
4. Insert Z-hook into highest adjustment bracket hole reachable.
5. Wrap cable end around adjustment bracket.

IMPORTANT: When auger control lever is disengaged, there should be slight slack in cable and no tension.

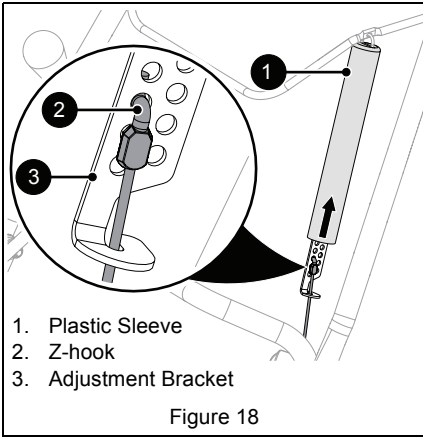

6. Start engine and engage auger control lever to ensure proper operation.
7. Release auger control lever and ensure paddle rotation stops.

IMPORTANT: Cable tension should not be excessive.

8. Reposition sleeve over adjustment bracket.

REPLACE DRIVE BELT

Remove Drive Belt

1. Stop engine and wait for all moving parts to stop and for hot parts to cool.
2. Disconnect spark plug wire.
3. Remove belt cover hardware and remove cover. Retain all parts. See Figure 19.

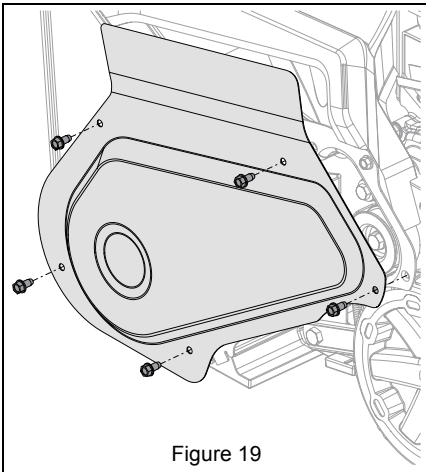

See Figure 20.

4. Disconnect extension spring from idler arm.
5. Remove belt from drive sheave, idler sheave and engine sheave.

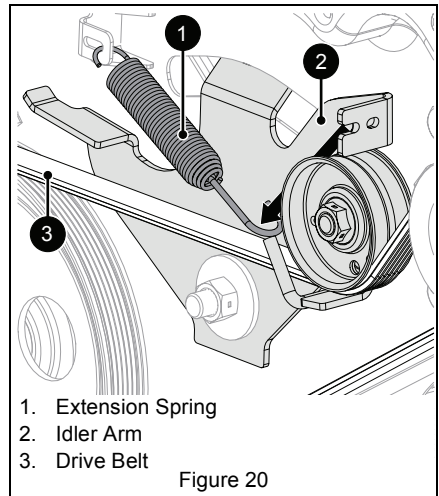

Install Drive Belt

See Figure 21.

1. Install new belt around engine sheave and align with drive and idler sheaves.
2. Reinstall extension spring onto idler arm.

IMPORTANT: Ensure belt has tension and is aligned in all sheaves.

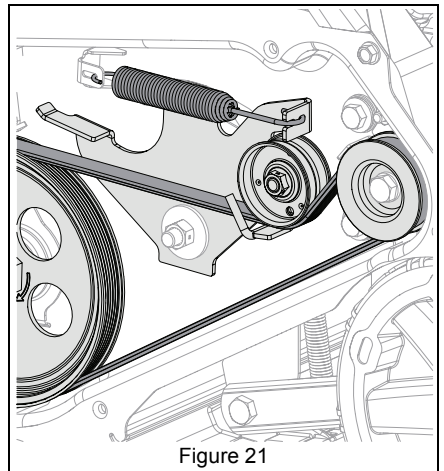

3. Reinstall belt cover and secure with original hardware.
4. Reconnect spark plug wire.

REPLACE SCRAPER BLADE

Replace scraper blade when worn too much or with every other auger paddle replacement.

Remove Scraper Blade

1. Stop engine and wait for all moving parts to stop and for hot parts to cool.
2. Tip unit back onto handlebar bend. See Figure 14.

NOTICE: DO NOT tip beyond bend or oil may leak from engine.

See Figure 22.

3. Disconnect spring hooks from scraper blade, remove from unit and discard.
4. Using a wrench, hold pivot rod stationary and remove hardware retaining pivot rod and blade. Retain hardware.

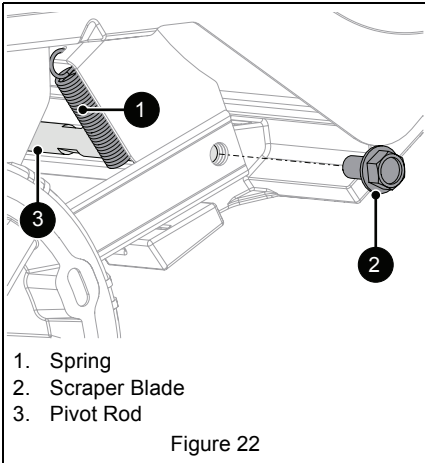

5. Remove pivot rod from scraper blade and discard blade. See Figure 23.

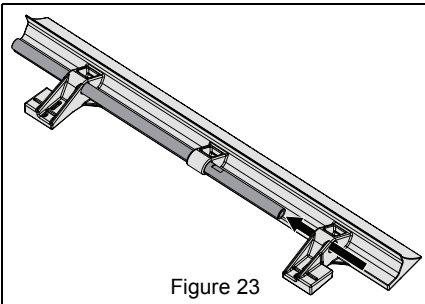

Install Scraper Blade

1. Insert pivot rod through new scraper blade.

IMPORTANT: Reinstall pivot rod so wrench flats are positioned toward the right side of unit. See Figure 24.

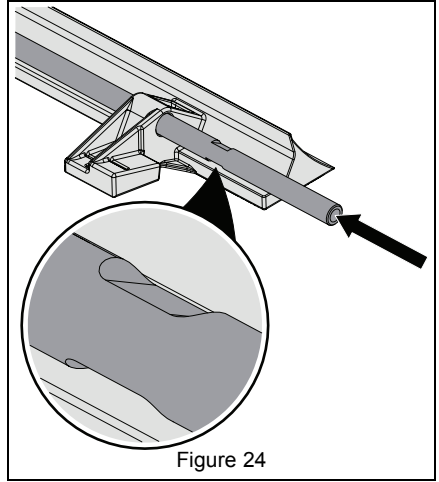

See Figure 25.

2. Secure scraper blade assembly to housing with original hardware.
3. Install spring hooks to frame and around scraper blade. Make sure blade has tension.

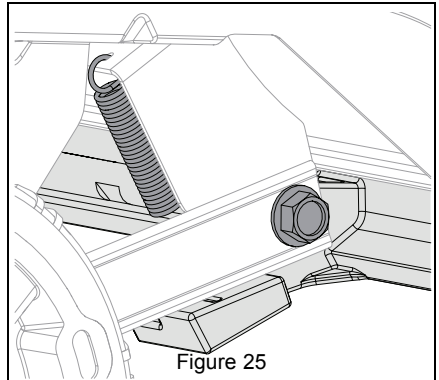

STORAGE



WARNING: AVOID INJURY. Read and understand the *Safety* section before proceeding.

SHORT TERM STORAGE

1. Engage auger momentarily to remove loose or melting snow to prevent auger shaft from freezing.
2. Tighten all hardware to correct specifications.
3. Inspect unit for visible signs of wear or damage. Repair as needed.
4. Apply a light layer of oil or anti-rust compound on bare metal areas.
5. Prepare fuel system for storage.

NOTICE: Ariens recommends using a quality fuel stabilizer in all fuel. Gasoline left in the fuel system without a stabilizer, even for short periods of time, deteriorates and leaves gummy deposits in the system that may damage the carburetor and fuel hoses, filter and tank. For the best effectiveness, add stabilizer to all fuel containers whenever purchasing fuel. Add the stabilizer to the container before adding fuel.

- a. Add Ariens fuel stabilizer (see *Service Parts* on page 13) or equivalent according to manufacturer's instructions to the fuel tank and any fuel containers with remaining fuel.
 - b. Run engine outdoors for at least 5 minutes to allow stabilizer to reach the carburetor.
6. Turn fuel valve to the off position and allow engine to stop on its own.
 7. Push engine switch into the stop position.
 8. Store unit in a cool, dry, protected area. Do not store unit outdoors.

LONG TERM STORAGE

1. Perform all short-term storage items.
2. Wash salt and other corrosive ice-melting agent residue from unit with mild soap and low-pressure water.

IMPORTANT: Never spray unit with high-pressure water.

3. Touch up all scratched painted surfaces.
4. Store unit in a cool, dry, protected area. Do not store unit outdoors.

START-OF-SEASON FUEL PREPARATION

Before opening the fuel valve for the first time after long-term storage, add fresh, stabilizer-treated fuel to the fuel tank and any fuel containers with remaining fuel.

ACCESSORIES

See your Ariens dealer for a complete list of compatible accessories and attachments for your unit.

Description	Part No.
Sno-Thro Cover Kit	73801100
Protective Floor Mat	70707600
Maintenance Kit*	73801000

*Includes 16 oz. 5W-30 engine oil, spark plug, fuel stabilizer and non-stick spray (Snow-Jet).

TROUBLESHOOTING

Problem	Probable Cause	Correction
Engine will not start.	Engine switch in stop position.	Push engine switch to run position. See <i>Engine Switch</i> on page 9.
	Fuel valve is closed.	Turn fuel valve to on position. See <i>Fuel Valve</i> on page 9.
	Fuel tank is empty.	Fill fuel tank with fuel. See <i>Before Operation</i> on page 10.
	Engine not primed.	Press the primer bulb twice. See <i>Primer Bulb</i> on page 9.
	Spark plug wire is disconnected.	Connect spark plug. Refer to engine manual.
	Choke is off.	Turn choke control knob to on position. See <i>Choke Control Knob</i> on page 9.
	Excessive fuel in engine cylinder (flooded).	Turn choke control knob to off position and reattempt starting. See <i>Start The Engine</i> on page 11.
	Faulty spark plug.	Replace spark plug.
	Engine is faulty.	See your Ariens Dealer.
Engine starts hard or runs poorly.	Fuel mixture too rich.	Turn choke control knob to off position. See <i>Choke Control Knob</i> on page 9.
	Spark plug is faulty, fouled or incorrectly gapped.	Clean and correctly set spark plug gap (refer to engine manual) or see your Ariens Dealer.
	Fuel cap vent is blocked.	Install new fuel cap.
Excessive vibration.	Loose parts or damaged auger paddles.	Check for loose or missing hardware or replace auger paddles. See <i>Replace Auger Paddles</i> on page 14.
Excessive snow left behind.	Scraper blade is worn.	Replace scraper blade. See <i>Replace Scraper Blade</i> on page 17.
Snow does not discharge.	Auger drive belt is loose or damaged.	Replace belt or adjust auger control cable. See <i>Replace Drive Belt</i> on page 16 and <i>Adjust Auger Cable</i> on Page 15.
	Discharge chute is clogged with snow.	Stop engine and close fuel valve. Clean discharge chute and auger housing with a tool. DO NOT use your hands to clean discharge chute.
	Auger paddles are worn or damaged.	Replace auger paddles. See <i>Replace Auger Paddles</i> on page 14.

SPECIFICATIONS

Model Number	938024	938025
Description	Professional 21 SSR	Professional 21 SSRC
Engine		
Engine Model	AX 208	
Displacement – cm ³ (in ³)	208 (12.7)	
Maximum RPM – No load	3600 ± 50	
Oil Capacity – L (Pt.)	0.47 (1.0)	
Fuel Tank Capacity – L (Qt.)	1.4 (1.5)	
Fuel Octane Rating	See Engine Manual	
Starter	Recoil	
Size and Weight		
Length – cm (in)	129.0 (50.8)	
Width – cm (in)	53.8 (21.2)	
Height – cm (in)	105.9 (41.7)	
Weight – kg (lb)	39.5 (87.0)	40.5 (89.2)



Sno-Thro[®], Sno-Tek[®] and Finishing Tool Equipment Limited Warranty

Ariens Company (Ariens) warrants to the **original purchaser** that Ariens, Gravely, Parker, and Countax brand chore-performing equipment (including Sno-Thro[®] and Sno-Tek[®] equipment) purchased on or after 1/1/2016 will be free from defects in material and workmanship for the time period noted in the chart below. Equipment put to personal use around a single household or residence is considered "Consumer Use"; equipment put to any business use (agricultural, commercial, or industrial) or used at multiple locations is considered "Commercial Use." If any product is rented or leased, then the duration of these warranties shall be 90 days after the date of purchase.

An authorized Ariens dealer (Ariens brand products), Gravely dealer (Gravely brand products), Parker dealer (Parker brand products), or Countax dealer (Countax brand products) will repair any defect in material or workmanship, and repair or replace any defective part, subject to the conditions, limitations and exclusions set forth herein. Such repair or replacement will be free of charge (labor and parts) to the original purchaser except as noted below.

Warranty Code	Product Group	Warranty Period Consumer Use	Warranty Period Commercial Use
PA	Log Splitters, Brushes, String Trimmers, Edgers	3 Years	90 Days
PB	Professional Powered Brushes	3 Years	1 Year
PC	Tillers	2 Years	90 Days
PD	Vacuums, Blowers, Sweepers, Truck Loaders, Lawn Rakes, Sprayers, Aerators, etc.	1 Year	1 Year
PE	Pressure Washer, Generators	3 Years	1 Year
SA	Professional Sno-Thro [®] , Professional 21	3 Years	1 Year
SB	Compact, Deluxe, Platinum, AMP [™] Sno-Thro [®] , Path-Pro [®]	3 Years	90 Days
SC	Sno-Tek [®]	2 Years	90 Days
SD	EFI Sno-Thro [®]	3 Years	90 Days
UA	Utility Vehicles	1 Year	1 Year
N/A	Service (Replacement) Parts	90 Days (no labor)	90 Days (no labor)
SE	920-Series Classic	3 Years	90 Days

Special Extensions

The chart below details special extensions to this warranty:

Warranty Code	Warranty Exception	Warranty Period	Use	Detail
SA	Cast Iron Auger Gear Case	5 Years	All	5 Years for all users including Commercial
SB, SD	Cast Iron Auger Gear Case	5 Years	Consumer	5 Years for Consumer use; 1 Year for Commercial Use
SB	Batteries for AMP [™] Sno-Thro [®]	2 Years	Consumer	100% first year; prorated second year.
SE	Aluminum Auger Gearcase	3 Years	Consumer	Commercial 90 Days

Exceptions and Limitations

The chart below details special exceptions to this warranty:

Warranty Code	Warranty Exception	Warranty Period	Use	Detail
All (Exc. SB)	Batteries	1 Year	All	Prorated
All	Belts, Muffler, Tires	None	Commercial	These components are not covered when used commercially.
All	Cloth, Plastic, and Rubber Components (Including Belts and Cables)	Maximum 2 Years	All	Warranty is limited to 2 years for consumer use. (1 year for warranty code "PD".) Except as noted above, these components are covered for defect, not for wear.
SA, SB, SC, SD, SE	Idlers	Maximum 2 Years	All	Warranty is limited on idlers to 2 years for consumer use.
All	Engines	See Engine Manufacturer's Warranty	All	Engines are covered by engine manufacturer's warranty. Refer to engine manufacturer's warranty statement.

Customer Responsibilities

Register the product immediately at the time of sale. If the dealer does not register the product, the customer must complete the product registration card in the literature package and return it to Ariens Company, or register the unit online at www.ariens.com, www.gravely.com, www.countax.com or www.parkersweeper.com.

To obtain warranty service, the **original purchaser** must:

- Perform the maintenance and adjustments explained in the Owner's Manual.
- Promptly notify Ariens or an authorized Ariens, Gravely, Parker or Countax service representative of the need for warranty service.
- Transport the product to and from the place of warranty service at owner's expense.
- Have the warranty service performed by an authorized Ariens, Gravely, Parker or Countax service representative.

To Find an Authorized Service Representative:

In the U.S. and Canada:		
Use the dealer locator on our websites: www.ariens.com • www.gravely.com		
Or contact us by mail or by phone:		
In the U.S., Canada, Mexico, Caribbean, Central and South America:	In Europe, Asia, Africa or the Middle East:	In Australia or New Zealand:
Ariens Company 655 W. Ryan Street Brillion, WI 54110 Phone: (920) 756 - 4688 www.ariens.com	Ariens Company Limited Great Haseley, Oxford OX44 7PF United Kingdom Phone: +44 800 597 7777 www.countax.co.uk	Allpower Industries Pty Ltd 128 Bridge Rd Keysborough VIC 3173 Australia Phone: +61 1800 333 428 www.allpower.com.au

Exclusions – Items Not Covered by This Warranty

- Parts that are not genuine Ariens, Gravelly, Parker or Countax service parts are not covered by this warranty and may void the warranty.
- Damages resulting from the installation or use of any part, accessory, or attachment which is not approved by the Ariens Company for use with product(s) identified herein are not covered by this warranty.
- The following maintenance, service and replacement items are not covered by this warranty unless they are noted in the Limitations section above: lubricants, spark plugs, oil, oil filters, air filters, fuel filters, brake linings, brake arms, brake shoes, skid shoes, scraper blades, shear bolts, mower blades, mower vanes, brushes, headlights, light bulbs, knives, cutters, and single-stage impellers.
- Any misuse, alteration, improper assembly, improper adjustment, neglect, or accident which requires repair is not covered by this warranty.
- **Use of gasoline blends exceeding 10% ethanol voids any and all warranties.**
- Products are designed to the specifications in the area that the product was originally distributed. Different areas may have significantly different legal and design requirements. This warranty is limited to the requirements in the area in which the unit was originally distributed. Ariens Company does not warrant this product to the requirements of any other area. Warranty service is limited to service within the area originally distributed.
- In countries other than the United States and Canada, contact the Ariens Company dealer for warranty policies that govern within your country. Rights may vary from country to country and within any one country.
- Normal Wear: This warranty does not cover repair when normal use has exhausted the useful life of a part such as a high pressure hose, spray wand, nozzles, trigger handle, supply hoses, quick couplers, gaskets, valves, pistons, pump valve assemblies, o-rings, water and oil seals.

Special Exclusions on Utility Vehicles

The following uses void the warranty terms on Utility Vehicles (Warranty Code UA):

- Renting or leasing the utility vehicle.
- Using the utility vehicle to tow or carry loads in excess of the limits specified in the Owner/Operator Manual.
- Modifying the utility vehicle with parts and accessories that are not genuine or authorized Ariens or Gravelly parts or accessories.
- Modifying the utility vehicle without express written authorization from Ariens Company.
- Operating the utility vehicle when it has not been completely and properly assembled and pre-delivered by an authorized Gravelly dealer.

Disclaimer

Ariens Company may from time to time change the design of its products. Nothing contained in this warranty shall be construed as obligating Ariens Company to incorporate such design changes into previously manufactured products, nor shall such changes be construed as an admission that previous designs were defective.

LIMITATION OF REMEDY AND DAMAGES

Ariens Company's liability under this warranty, and under any implied warranty that may exist, is limited to repair of any defect in workmanship, and repair or replacement of any defective part. Ariens Company shall not be liable for incidental, special, or consequential damages (including lost profits). Some states do not allow the exclusion of incidental or consequential damages, so the above limitation or exclusion may not apply to you.

AUSTRALIAN CONSUMER LAW

The following applies solely to warranties subject to Subsection 102(1) of the Australian Consumer Law: Our goods come with guarantees that cannot be excluded by the Australian Consumer Law. You are entitled to a replacement or refund for a major failure and for compensation for any other reasonably foreseeable loss or damage. You are also entitled to have the goods repaired or replaced if the goods fail to be of acceptable quality and failure does not amount to a major failure.

DISCLAIMER OF FURTHER WARRANTY

Ariens Company makes no warranty, express or implied, other than what is expressly made in this warranty. If the law of your state provides that an implied warranty of merchantability, or an implied warranty of fitness for particular purpose, or any other implied warranty, applies to Ariens Company, then any such implied warranty is limited to the duration of this warranty. Some states do not allow limitations on how long an implied warranty lasts, so the above limitation may not apply to you.

This warranty gives you specific legal rights, and you may also have other rights which vary from region to region.



ARIENS
THE KING OF SNOW

655 West Ryan Street
Brillion, WI 54110

ariensstore.com
arienscusthelp.com

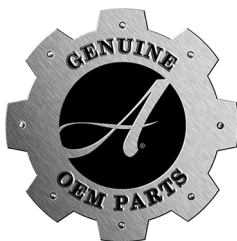

parts.ariens.com

WARNING

The engine exhaust from this product contains chemicals known to the State of California to cause cancer, birth defects and other reproductive harm.

An *Ariens* Company Brand

