



► Models LSLD

Litestak® Status Indicator with LED Lamp

Federal Signal’s Litestak® status indicators are vertical columns of light that indicate status in a full 360° radius.

The Litestak Model LSLD modular indicator light system allows the user to combine up to five interchangeable lamp units with a base power unit. Modules are sold separately for a truly customized indicator.

Light modules come complete with a 50,000-hour LED lamp; LED light output coordinates with the module’s impact-resistant polycarbonate lensing. LED lamps consume less power, operate at a lower temperature, and are remarkably resistant to vibration, which makes them perfect for use in heavy-duty, high vibration applications.

An optional Sound Module (Models LSS or LSH—on page 24 and 26) can be added to the top of the Litestak column to create a dual purpose audible/visual status indicating signal. The LSS sound module allows the user to select from 32 tones via a simple dip switch panel. In applications where a single loud tone is all that is necessary, the LSH piezo-electric horn is a perfect audible addition.

Litestak is a versatile system that allows the user to select either steady burn or flash. A flasher is included on the 120VAC LSB unit only but can be purchased separately for 24VDC models. The Litestak base unit can be either surface mount or 3/4-inch NPT pipe mount. All Litestak models should be mounted base down.

FEATURES

- Available in 24VDC and 120VAC
- 50,000 hour, vibration-resistant LED lamp
- Surface mount and integrated 3/4-inch NPT pipe mount
- Five lens colors: Amber, Blue, Clear, Green and Red
- Indoor use only
- Type 1 enclosure
- UL and cUL Listed and CSA Certified

MODEL	DESCRIPTION	VOLTAGE	OPERATING CURRENT	MOUNT
LSB-024-240¹	Base	24-240VAC/DC	N/A	3/4" NPT Pipe/Surface
LSB-120¹	Base	120VAC 50/60Hz	N/A	3/4" NPT Pipe/Surface
LSBS¹	Base	24-240VAC/DC	N/A	Surface
LSLD-024^{2*}	Light Module	24VDC	80 mA	N/A
LSLD-120^{2*}	Light Module	120VAC 50/60Hz	45 mA	N/A

¹ Cap kit included.

² Includes lens, lamp and light module.

* Indicates color: (A) Amber, (B) Blue, (C) Clear, (G) Green or (R) Red

Litestak® with LED Lamp (LSLD)

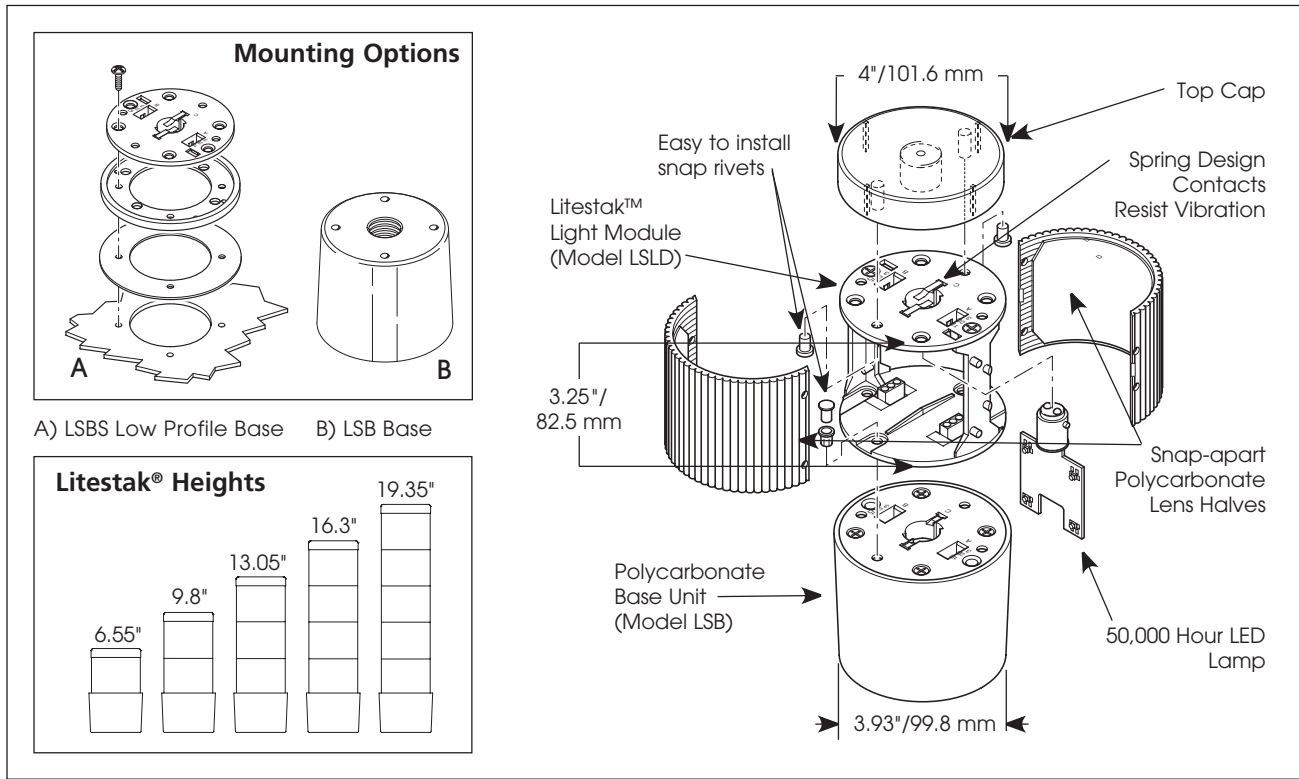

SPECIFICATIONS

Lamp Life:		50,000 Hours
Light Source:		LED Array
Operating Temperature:	0°F to 120°F	-18°C to 49°C
Net Weight, LSLD:	0.45 lbs	0.2 kg
Shipping Weight, LSLD:	0.7 lbs	0.32 kg
LSLD Height:	3.25"	82.5 mm
LSB Height:	3.3"	83.8 mm
LSLD Diameter:	3.93"	99.82 mm
LSB Diameter:	3.93"	99.82 mm

REPLACEMENT PARTS

Description	Part Number
Litestak Lens Kit ¹	K844700352A
Flasher, 24VDC	K8285237A
Flasher, 120VAC	K8285239A
LED Lamp 24VDC, Amber	K8107199A
LED Lamp 24VDC, Blue	K8107199A-03
LED Lamp 24VDC, Clear	K8107199A-04
LED Lamp 24VDC, Green	K8107199A-02
LED Lamp 24VDC, Red	K8107199A-01
LED Lamp 120VAC, Amber	K8107200A
LED Lamp 120VAC, Blue	K8107200A-03
LED Lamp 120VAC, Clear	K8107200A-04
LED Lamp 120VAC, Green	K8107200A-02
LED Lamp 120VAC, Red	K8107200A-01

HOW TO ORDER

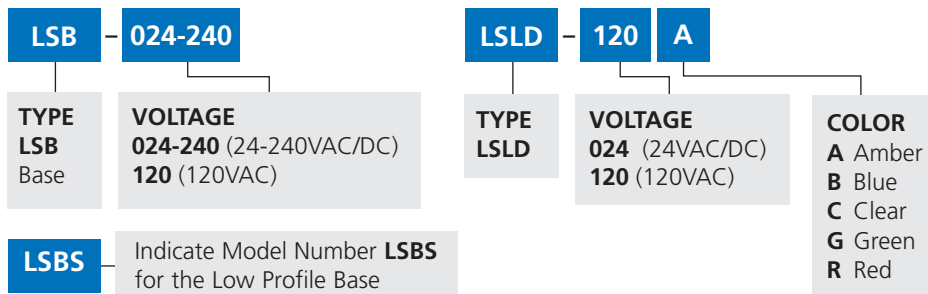

¹ Includes 1 each of lens: Amber, Blue, Clear, Green and Red (does not include blackout 1/2 lens), snap rivets and cap