

Assembly Instructions and Parts Manual

Chrome: 3TNZ8, 3TNZ9, 3TPA1, 3TPA2
 Zinc: 3TPA7, 3TPA8, 3TPA9, 3TPC1
 Black: 3TPC8, 3TPC9, 3TPD1, 3TPD2
 White: 3TPD9, 3TPE1, 3TPE2, 3TPE3

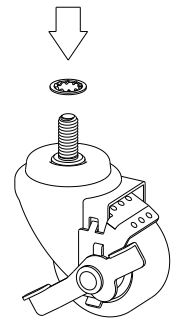

- Slide shelf (B) to top of U-handles (A). Attach the plastic split collets (C) to U-handles (A) at the desired height, locating the ridges of the collets into the grooves of the U-handle. Press shelf onto the collets firmly.
- Repeat step 1 for second shelf. The lower shelf should be located on the second lowest groove on the U-handle for maximum durability.
- Put washer through the top of the screw for each caster.

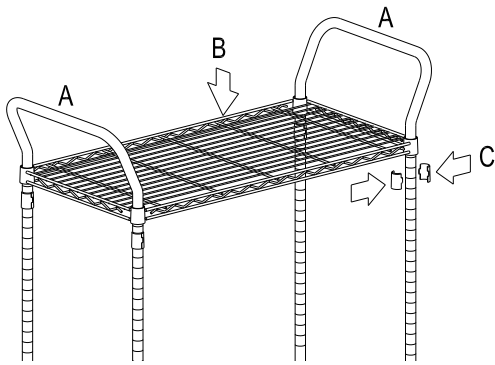
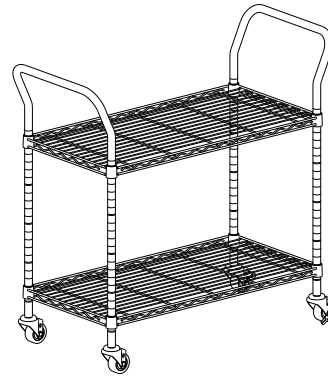
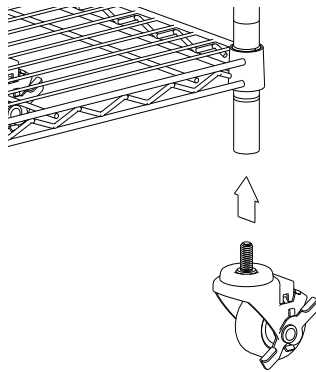

- Thread the casters (D & E) into the bottom of each post, locating brake casters (E) in opposite corners. Tighten with wrench.
- The cart is now ready for use.

A	B	C	D	E
U-handle	Shelf	Split Collet	Swivel Caster	Swivel Caster w/ Brake
2 pcs	2 pcs	8 pair	2 pcs	2 pcs

Stock Number	Surface Treatment	Dimension D x W x H	Max. Capacity	Replacement Part Numbers				
				A (set of 2)	B (each)	C (set of 8)	D (each)	E (each)
3TNZ8	Chrome	36X18X38	350 lbs.	MHLU3318BG	MHL1836CG	MHSLEEVEG	MH3TNZ801G	MH3TNZ802G
3TNZ9	Chrome	48X18X38	350 lbs.	MHLU3318BG	MHL1848CG	MHSLEEVEG	MH3TNZ801G	MH3TNZ802G
3TPA1	Chrome	36X24X38	350 lbs.	MHLU3324BG	MHL2436CG	MHSLEEVEG	MH3TNZ801G	MH3TNZ802G
3TPA2	Chrome	48X24X38	350 lbs.	MHLU3324BG	MHL2448CG	MHSLEEVEG	MH3TNZ801G	MH3TNZ802G
3TPA7	Zinc	36X18X38	350 lbs.	MHLU3318ZG	MHL1836ZG	MHSLEEVEG	MH3TNZ801G	MH3TNZ802G
3TPA8	Zinc	48X18X38	350 lbs.	MHLU3318ZG	MHL1848ZG	MHSLEEVEG	MH3TNZ801G	MH3TNZ802G
3TPA9	Zinc	36X24X38	350 lbs.	MHLU3324ZG	MHL2436ZG	MHSLEEVEG	MH3TNZ801G	MH3TNZ802G
3TPC1	Zinc	48X24X38	350 lbs.	MHLU3324ZG	MHL2448ZG	MHSLEEVEG	MH3TNZ801G	MH3TNZ802G
3TPC8	Black	36X18X38	350 lbs.	MHLU3318BG	MHL1836BG	MHSLEEVEG	MH3TNZ801G	MH3TNZ802G
3TPC9	Black	48X18X38	350 lbs.	MHLU3318BG	MHL1848BG	MHSLEEVEG	MH3TNZ801G	MH3TNZ802G
3TPD1	Black	36X24X38	350 lbs.	MHLU3324BG	MHL2436BG	MHSLEEVEG	MH3TNZ801G	MH3TNZ802G
3TPD2	Black	48X24X38	350 lbs.	MHLU3324BG	MHL2448BG	MHSLEEVEG	MH3TNZ801G	MH3TNZ802G
3TPD9	White	36X18X38	350 lbs.	MHLU3318WG	MHL1836WG	MHSLEEVEG	MH3TNZ801G	MH3TNZ802G
3TPE1	White	48X18X38	350 lbs.	MHLU3318WG	MHL1848WG	MHSLEEVEG	MH3TNZ801G	MH3TNZ802G
3TPE2	White	36X24X38	350 lbs.	MHLU3324WG	MHL2436WG	MHSLEEVEG	MH3TNZ801G	MH3TNZ802G
3TPE3	White	48X24X38	350 lbs.	MHLU3324WG	MHL2448WG	MHSLEEVEG	MH3TNZ801G	MH3TNZ802G

*Warning: Maximum load capacity rating is for evenly distributed load.

Chrome: 3TPA3 thru 3TPA6, 3TPV5, 3TPV6
 Zinc: 3TPC2 thru 3TPC7
 Black: 3TPD3 thru 3TPD8
 White: 3TPE4 thru 3TPE9

Assembly Instructions and Parts Manual

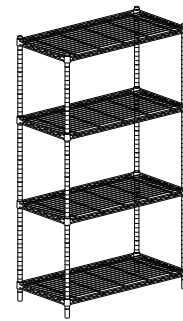
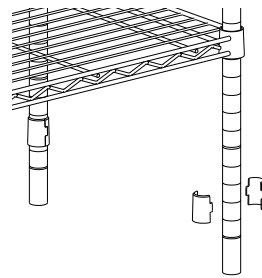
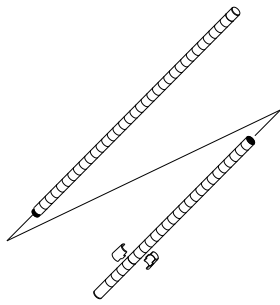

- Place upper post (A) over lower post joiner (B) and screw the two pieces together securely. Repeat for the remaining posts.
- Attach plastic split collets (D) to the posts, positioning the ridges of the collets into the grooves of the posts. Locate the bottom shelf on the second lowest groove on the post for maximum durability. Press shelf (C) firmly onto collets.
- Repeat steps 1 and 2 for the remaining shelves, locating the ridges of the collets into the grooves at the desired shelf heights.

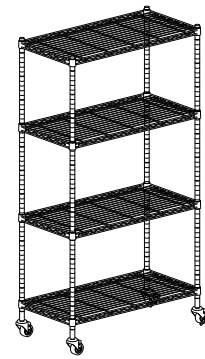
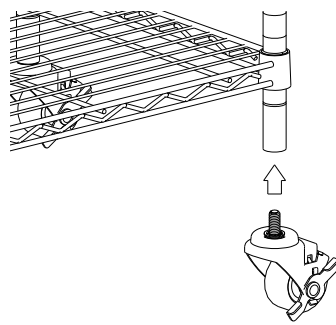
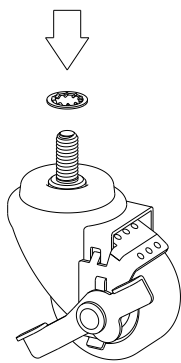

- Put washer through the top of the screw for each caster.
- Thread the casters (E & F) into the bottom of each post, locating brake casters (F) in opposite corners. Tighten with wrench.
- The cart is now ready for use.

A	B	C	D	E	F
4 pcs	4 pcs	4 pcs	16 pair	2 pcs	2 pcs

Stock Number	Surface Treatment	Dimension D x W x H	Max. Capacity	Replacement Part Numbers					
				A & B (1 Pair)	C (each)	D (4 pair)	E (each)	F (each)	
3TPA3	Chrome	36X18X67	600 lbs.	MHLP64CG	MHL1836CG	MHSLEEVEG	MH3TNZ801G	MH3TNZ802G	
3TPA4	Chrome	48X18X67	600 lbs.	MHLP64CG	MHL1848CG	MHSLEEVEG	MH3TNZ801G	MH3TNZ802G	
3TPV5	Chrome	60X18X67	600 lbs.	MHLP64CG	MHL1860CG	MHSLEEVEG	MH3TNZ801G	MH3TNZ802G	
3TPV6	Chrome	36X24X67	600 lbs.	MHLP64CG	MHL2436CG	MHSLEEVEG	MH3TNZ801G	MH3TNZ802G	
3TPA5	Chrome	48X24X67	600 lbs.	MHLP64CG	MHL2448CG	MHSLEEVEG	MH3TNZ801G	MH3TNZ802G	
3TPA6	Chrome	60X24X67	600 lbs.	MHLP64CG	MHL2460CG	MHSLEEVEG	MH3TNZ801G	MH3TNZ802G	
3TPC2	Zinc	36X18X67	600 lbs.	MHLP64ZG	MHL1836ZG	MHSLEEVEG	MH3TNZ801G	MH3TNZ802G	
3TPC3	Zinc	48X18X67	600 lbs.	MHLP64ZG	MHL1848ZG	MHSLEEVEG	MH3TNZ801G	MH3TNZ802G	
3TPC4	Zinc	60X18X67	600 lbs.	MHLP64ZG	MHL1860ZG	MHSLEEVEG	MH3TNZ801G	MH3TNZ802G	
3TPC5	Zinc	36X24X67	600 lbs.	MHLP64ZG	MHL2436ZG	MHSLEEVEG	MH3TNZ801G	MH3TNZ802G	
3TPC6	Zinc	48X24X67	600 lbs.	MHLP64ZG	MHL2448ZG	MHSLEEVEG	MH3TNZ801G	MH3TNZ802G	
3TPC7	Zinc	60X24X67	600 lbs.	MHLP64ZG	MHL2460ZG	MHSLEEVEG	MH3TNZ801G	MH3TNZ802G	
3TPD3	Black	36X18X67	600 lbs.	MHLP64BG	MHL1836BG	MHSLEEVEG	MH3TNZ801G	MH3TNZ802G	
3TPD4	Black	48X18X67	600 lbs.	MHLP64BG	MHL1848BG	MHSLEEVEG	MH3TNZ801G	MH3TNZ802G	
3TPD5	Black	60X18X67	600 lbs.	MHLP64BG	MHL1860BG	MHSLEEVEG	MH3TNZ801G	MH3TNZ802G	
3TPD6	Black	36X24X67	600 lbs.	MHLP64BG	MHL2436BG	MHSLEEVEG	MH3TNZ801G	MH3TNZ802G	
3TPD7	Black	48X24X67	600 lbs.	MHLP64BG	MHL2448BG	MHSLEEVEG	MH3TNZ801G	MH3TNZ802G	
3TPD8	Black	60X24X67	600 lbs.	MHLP64BG	MHL2460BG	MHSLEEVEG	MH3TNZ801G	MH3TNZ802G	
3TPE4	White	36X18X67	600 lbs.	MHLP64WG	MHL1836WG	MHSLEEVEG	MH3TNZ801G	MH3TNZ802G	
3TPE5	White	48X18X67	600 lbs.	MHLP64WG	MHL1848WG	MHSLEEVEG	MH3TNZ801G	MH3TNZ802G	
3TPE6	White	60X18X67	600 lbs.	MHLP64WG	MHL1860WG	MHSLEEVEG	MH3TNZ801G	MH3TNZ802G	
3TPE7	White	36X24X67	600 lbs.	MHLP64WG	MHL2436WG	MHSLEEVEG	MH3TNZ801G	MH3TNZ802G	
3TPE8	White	48X24X67	600 lbs.	MHLP64WG	MHL2448WG	MHSLEEVEG	MH3TNZ801G	MH3TNZ802G	
3TPE9	White	60X24X67	600 lbs.	MHLP64WG	MHL2460WG	MHSLEEVEG	MH3TNZ801G	MH3TNZ802G	

*Warning: Maximum load capacity rating is for evenly distributed load.