

Ventilation Solutions

Bathrooms



It's not a UFO. But it is out of this world.

A remote bath fan is not as alien as you might think.
Learn how Fantech solves problems you never knew existed.



Three things that Make a PB Remote Bath Fan the Right Choice for your next project.

1

Noise. Or lack thereof.

The icing on the cake with a remote fan installation is that the result is virtually **ZERO** sound.

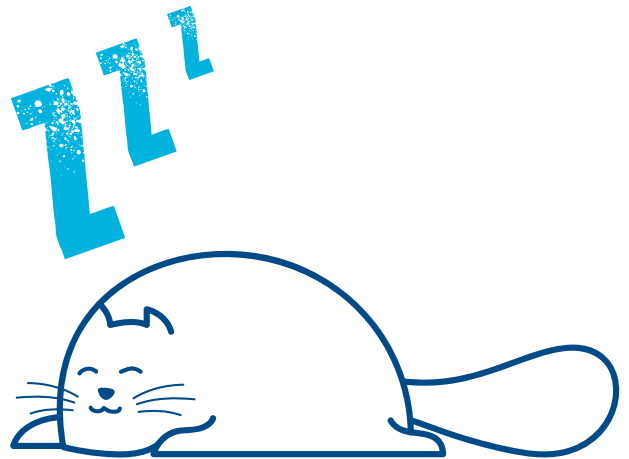

2

Small grille size.

PB Grilles are a fraction the size of traditional ceiling fan models.



— Whisper GreenSelect™ —



— InVent Nutone by Broan® —

3

2 baths for the price of 1.



x

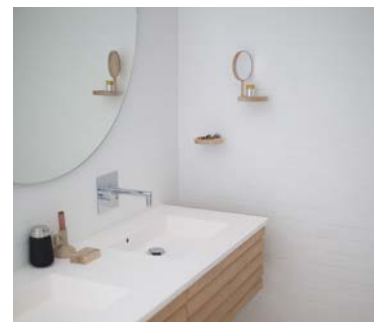

PB Series

Remote Mount Bath Fans for Single Bathrooms

PB 110 Remote Bath Fan

with one Ceiling Grille

The PB is a great option for getting humidity out of a space no matter how small. This petite configuration is perfect for your premium single bathroom application.

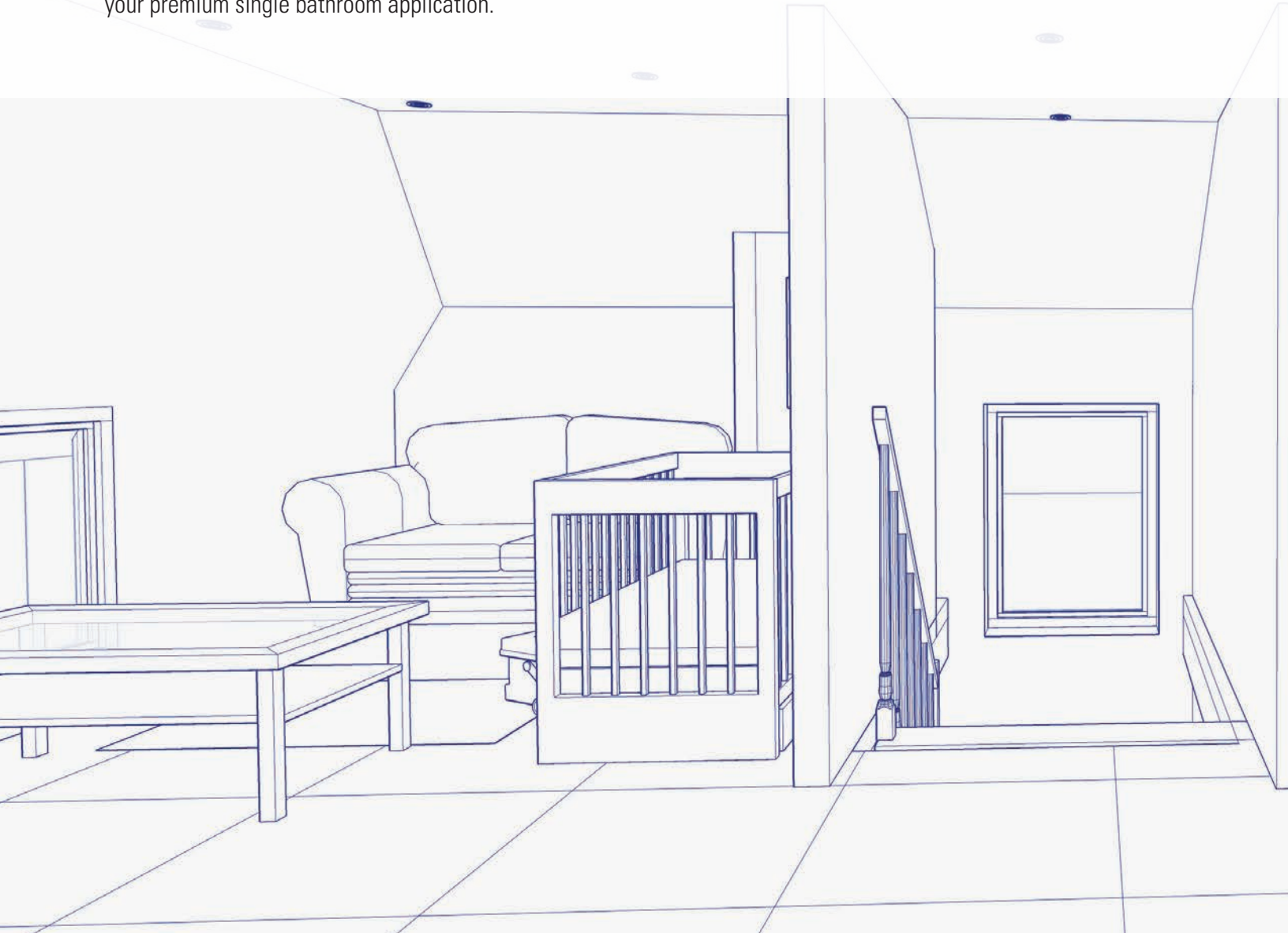

The Math is Simple

Full Bath

$$10' \times 7' = 70 \text{ sq ft } (<100) = \mathbf{70 \text{ CFM}}$$

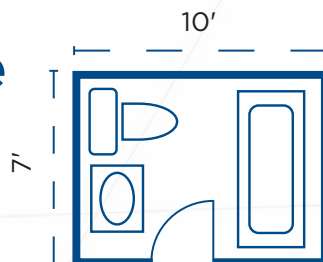

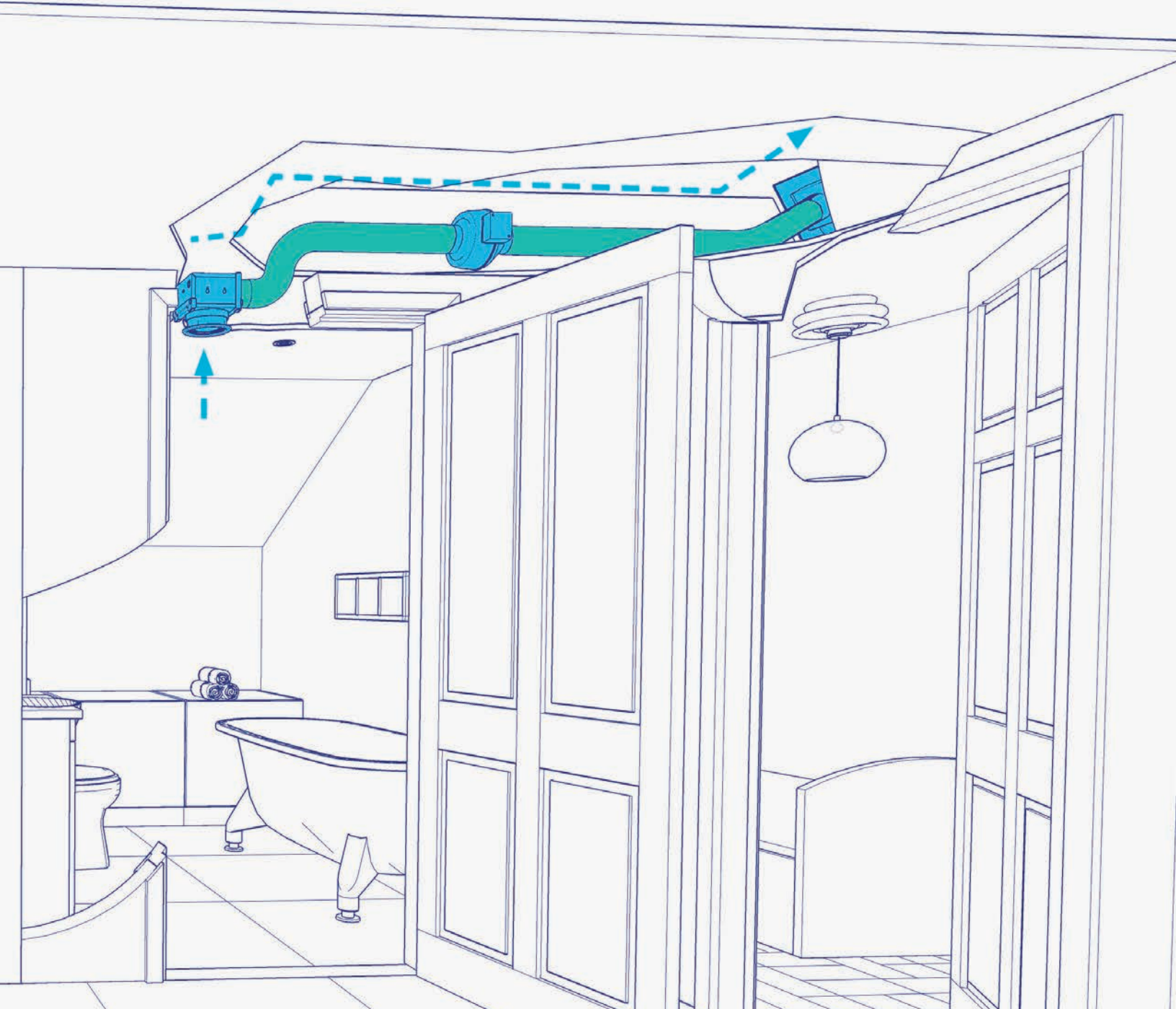

PB 110
110 cfm
12 lbs



Additional Accessories



FIDT 4
Flexible Duct

AND



RC 4P
Roof Cap

AND



VT20M
20 Min Timer/
Fan Control

PB Series

Premium Bath Fans • Dual Grilles

The key for clean oversized baths is spot ventilation

Dual grille Premium Bath fans can effectively ventilate two areas of the bath or two different bathrooms. The fan motor is installed away from the living area for super quiet operation.

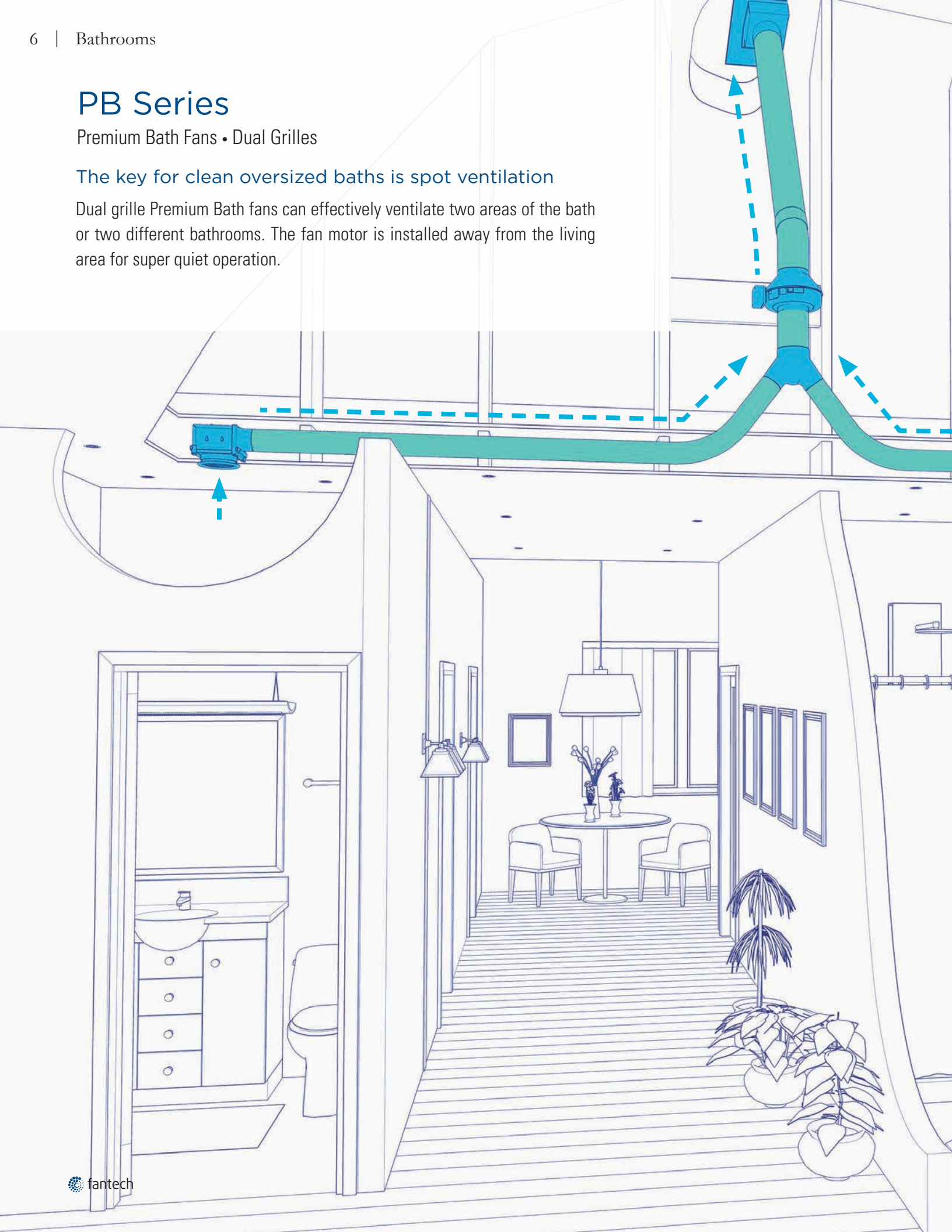

The Math is Simple

Full Bath + 1/2 Bath

For a double bath you simply add the CFM requirements of two bathrooms and add them together.

$9' \times 13' = 117 \text{ sq ft } (>100 \text{ sq ft})$

1 toilet + 1 tub = **100 CFM**

$7' \times 8' = 56 \text{ sq ft } (<100 \text{ sq ft}) = \text{56 CFM}$

Add results from both.

$100 + 56 = \text{156 CFM}$

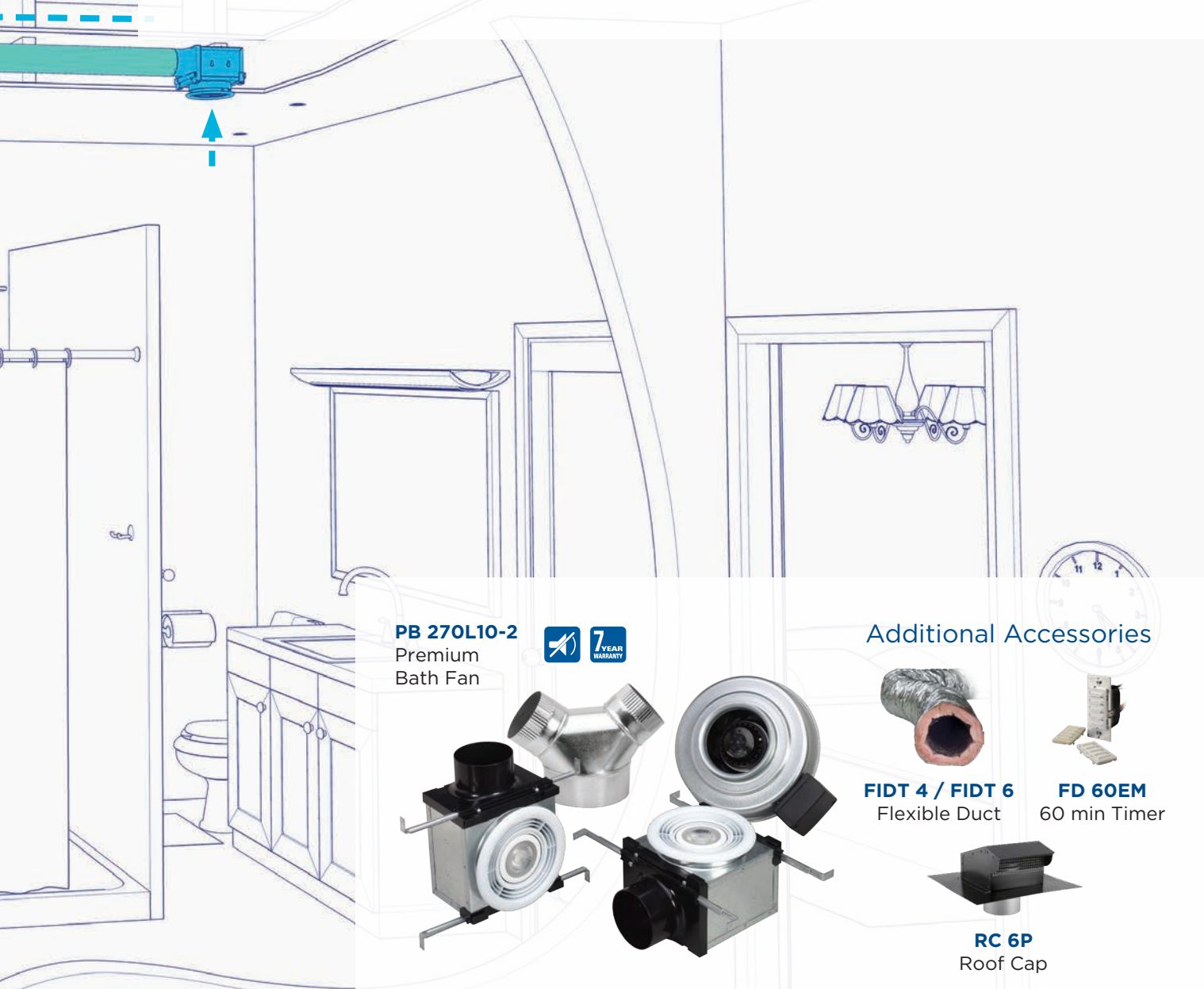
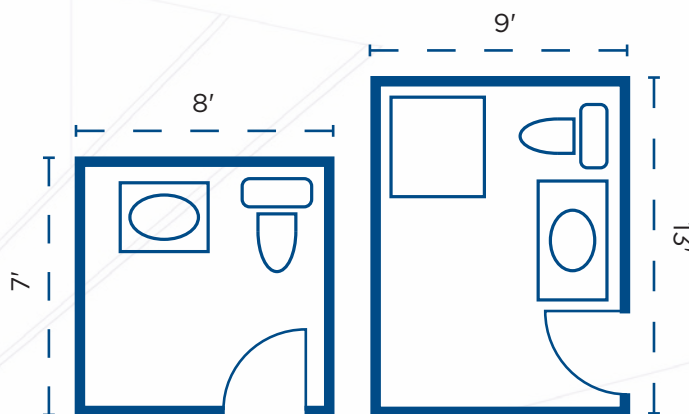

PB 270L10-2
Premium
Bath Fan



Additional Accessories



FIDT 4 / FIDT 6
Flexible Duct



FD 60EM
60 min Timer



RC 6P
Roof Cap



Why choose a remote mounted bath fan?

It is a common misconception that **multiple** bath fans have to be purchased for **every** bathroom in your home. It is also a misconception that bath fans have to be **loud** and **annoying**. But Fantech has a better solution to both of these problems in one convenient package.

PB Series

Premium Bath Fans • Single Grilles

Clear the air in smaller baths and powder rooms

A small-scale grille mounts in the ceiling while the fan motor mounts in a remote location away from the living area. The result is a quiet yet powerful combination designed to help protect your home from the damaging effects of humidity. PB fans are designed for intermittent or continuous operation to meet **ASHRAE Standard 62.2**.

PB 110 (PB 190) Premium Bath Fan
with one Ceiling Grille



PB 110
110 cfm
9 lbs











PB 110L10 Premium Bath Fan
with a Dimmable 10W LED Light/Grille



PB 110L10
110 cfm
7 lbs



Accessories for Single Grille PB Series

<p>PB 110 PB 110L10</p>  <p>FIDT 4 Flexible Duct</p>	AND	 <p>RC 4P Roof Cap</p>	OR	 <p>HS 4W Exhaust Vent</p>	AND	 <p>IPHS5 Humidity Sensor</p>	OR	 <p>FD 60EM 60 min Timer</p>
<p>PB 190</p>  <p>FIDT 6 Flexible Duct</p>	AND	 <p>RC 6P Roof Cap</p>	OR	 <p>HS 6W Exhaust Vent</p>				

Did You Know Fantech Remote Bath Fans...

...can be linked to up to **three*** remote locations?

...can be paired with **automatic** humidity sensors and timers?

...have premium **designer** grille options?

*number of locations depends on model selected

PB Series

Premium Bath Fans • Dual Grilles

The key for clean oversized baths is spot ventilation

Dual grille Premium Bath fans can effectively ventilate two areas of the bath or two different bathrooms. Small 7" ceiling grilles (with or without lights) can be easily positioned directly over showers, whirlpool tubs, steam showers, toilet or vanity. The fan motor is installed away from the living area for super quiet operation. PB fans are designed for intermittent or continuous operation to meet **ASHRAE Standard 62.2**.

PB 270L10-2 Premium Bath Fan
with Two 10W Dimmable LED Lights/
Ceiling Grilles



PB 270L10-2
270 cfm
16 lbs



PB 270-2 (PB 370-2) Premium Bath Fan
with Two Ceiling Grilles



PB 270-2
270 cfm
16 lbs

PB 370-2
370 cfm
17 lbs



Accessories for Dual Grille PB Series



FIDT 6
Flexible Duct

AND



RC 6P
Roof Cap

OR



HS 6W
Exhaust Vent

AND



IPHS5
Humidity Sensor

OR



FLD 60
Light/Fan Switch

This Mocha was brought to you by Fantech

This café needs fresh air in its powder rooms so customers aren't distracted by smells other than their freshly ground coffee. In a configurable commercial environment you also need flexibility.

A Fantech remote Bathroom Fan allows a contractor to centrally mount a fan while taking care of multiple inlets at once. But what's more, if your client calls you back to move or add an additional bathroom, you can easily move the inlets without hassling with extra electrical or the purchase of additional expensive hardware.

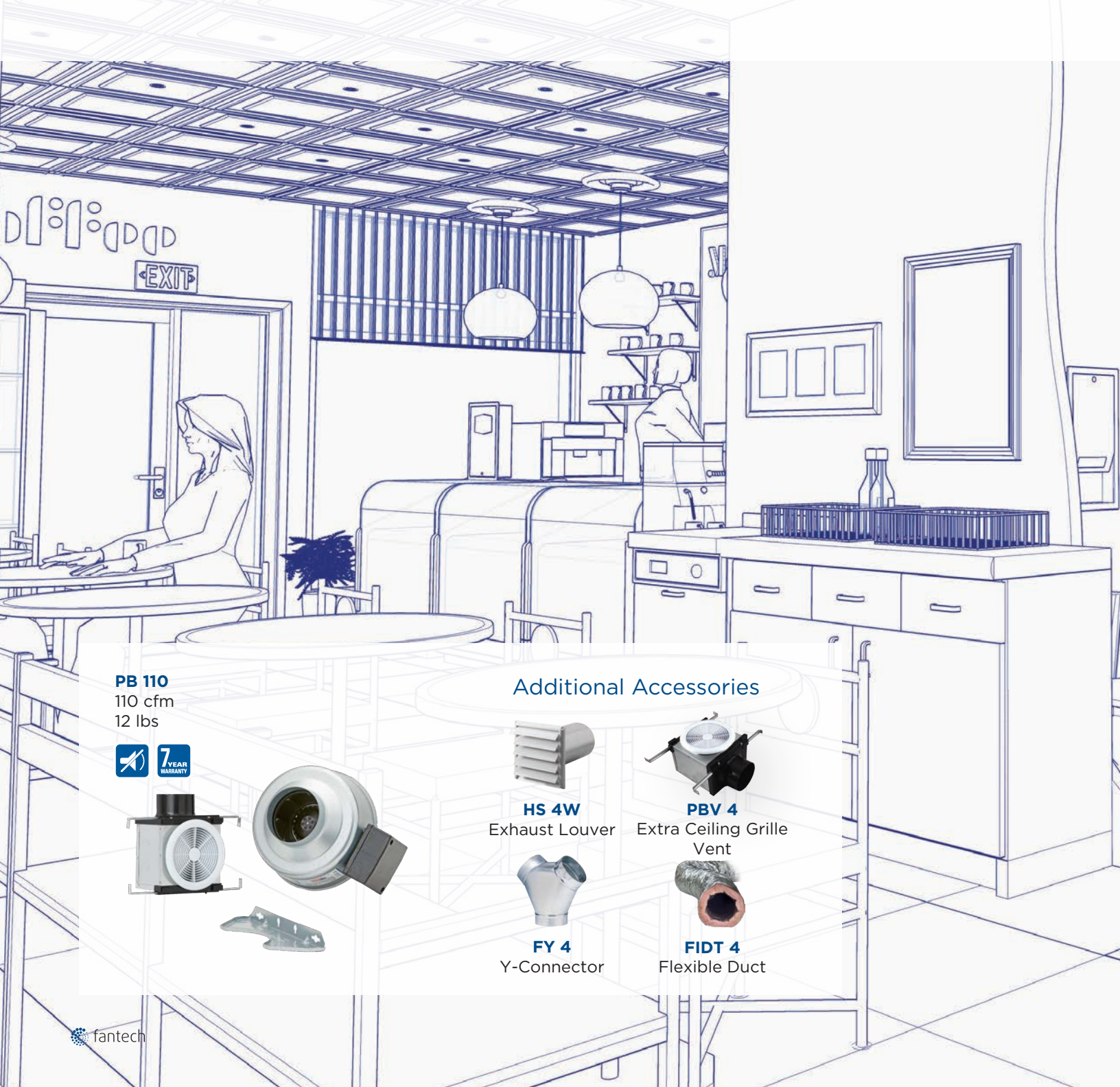

PB 110
110 cfm
12 lbs



Additional Accessories



HS 4W
Exhaust Louver

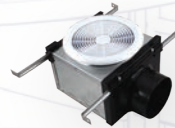

PBV 4
Extra Ceiling Grille Vent



FY 4
Y-Connector



FIDT 4
Flexible Duct



Why PB110?

In most situations a PB110 is not suitable for a split bath. But because of the compact nature of this commercial space, we can easily implement a PB 110 to meet our needs.

PBW Series

Exterior Mount Bath Fans

No where to exhaust a fan?

We have expanded our Premium Bath Fan selection to include a quartet of models powered by exterior mounted wall fans. An excellent alternative when space is an issue or direct venting vertically is impossible. Ideal for homes, condominiums and apartment complexes. Choose lit or unlit models. PB fans are designed for intermittent or continuous operation to meet **ASHRAE Standard 62.2**.

PBW 110 Exterior Wall Mount Bath Fan

with one Ceiling Grille



PBW 110L10 Exterior Wall Mount Bath Fan

with a Dimmable 11W LED Light



Introducing the IPHS5

A completely hands off solution that pairs well with our virtually silent, remote bath fans for a truly premium experience.

- Automatically detects excess humidity
- Continuously monitors and manages humidity
20 min ON / 40 min OFF mode
- Manual operation
- Meets CALGREEN requirements
- Meets the requirements of 2016 California Title 24
- Meets the requirements of ASHRAE 62.2
- Five-Year Limited warranty

NEW

IPHS5
Humidity
Sensor
1 lbs



Check fantech.net to ensure your selection is compatible with the IPHS5.



PBW Series

Exterior Mount Bath Fans

PBW 110 Exterior Wall Mount Bath Fan with one Ceiling Grille

The PBW is a great option for those spaces that don't allow for a traditional inline fan. Don't let a cramped space be a reason to settle for the noisy alternatives.



PBW 110
110 cfm
12 lbs



Additional Accessories



FIDT 4
Flexible Duct

AND



IPHS5
Humidity Sensor

OR



VT20M
20 Min Timer/
Fan Control

CVS Series

MULTI-PORT of Entry

No where to exhaust a fan?

A multi-port exhaust fan works the best for home spas or two separate bathrooms because you can address exhaust in the areas where it's needed the most: the steam shower, toilet and, of course, your Jacuzzi tub.

CVS Series is an exhaust air fan for areas where space is limited. They are also a popular choice for use between floors in apartment buildings.

Airflows between 250 and 400 cfm.

CVS Multi-port Exhaust Fan

with up to 4 locations



CVS 275A

90W, 245 cfm
11 lbs

CVS 300A

120W, 355 cfm
16 lbs

CVS 400A

150W, 404 cfm
20 lbs



Grilles! Grilles! Grilles!

Fantech offers many grille designs for your unique wants and styles. Take a look at our accessories for more. These can be used in any appropriately sized duct opening.



Accessories for Bathroom Exhaust

Expansion Grilles • Controls • Duct Components

PBV 4 (PBV 6)

Ceiling Grille Vent



PBV 4



PBV 6

Includes damper, four hanger bars. Fits between 2" x 6" construction. PBV 4 model for use with PB110 and PB270 Series. PBV 6 for PB 370 fan.

Housing dimensions (inch):

PBV4 $7 \frac{3}{16} \times 7 \frac{3}{16} \times 5 \frac{5}{16}$

PBV6 $8 \times 8 \times 7 \frac{1}{8}$

PBL 10-4

Ceiling Grille with a Dimmable 11W LED Light



Includes damper, four hanger bars and a dimmable 11W LED bulb. Fits between 2" x 6" construction. For use with PB 110L10, PB 270L10-2, PB 270L10V-2 and PB 270L7-L10-2.

Housing dimensions (inch):

PBL10-4 $7 \frac{3}{16} \times 7 \frac{3}{16} \times 5 \frac{5}{16}$

FIDT Series

Insulated Flex Duct*



Flexible round insulated duct. The insulation provides greater thermal efficiency to save energy. The product is also covered in a heavy duty, silver jacket for durability. UL listed. Available in 25-foot lengths.

FIDT 4 4", 7 lbs

FIDT 6 6", 9 lbs

RC Series

Roof Cap



Roof Cap with damper flap closure, duct connection and screened exhaust opening. Painted black.

RC 4P 4", 2 lbs

RC 6P 6", 3 lbs

HS Series

Louvered Shutter for Exhaust



Plastic louvered shutter with duct connection. For exhaust air only. Used with premium bathroom fans or dryer exhaust.

HS 4W 4", 1 lbs

HS 6W 6", 1 lbs

FLD 60

Bathroom Light/Fan Switch



Designed as a replacement for the bathroom fan and light switch. By using a microprocessor to monitor and control fan operation, a precise amount of ventilation can be provided. Allows continuous operation of the fan for up to 1 hour after light switch is turned off.

FLD 60 1 lbs

FD 60EM

Electronic Push Button Timer



Provides convenient timed bath fan control: 10, 20, 30 and 60 minutes. Fits standard single gang box. Ideal for multiple switching locations. Three panel colors. 120V / 20A.

FD 60EM 1 lbs

IPHS5

Humidity Sensor



Humidity sensor for automatic fan control. Humidity adjustment, time-out settings and 20/40 air-cycle mode. cULus, ASHRAE 62.2, Title 24 listed. White.

IPHS5 1 lbs

* We recommend to use of the insulated flex duct FIDT with our Premium Bathroom Fans.

CVS Series

Multi-port Exhaust Fans

The Perfect Home Spa Solution

Offering the most intake grille options for a remote ventilator solution with up to four ports available. Perfect for a home spa or multi bathroom scenario. Specially designed to fit in your attic or in the space between floors in a multi-level home.

CVS 300A
Exhaust Multi-
Port Fan



Additional Accessories



HS 6W
Exhaust Louver



MGE 4
Exhaust Grille



RSK 4 / RSK 6
Flexible Duct



FIDT 4 / FIDT 6
Flexible Duct

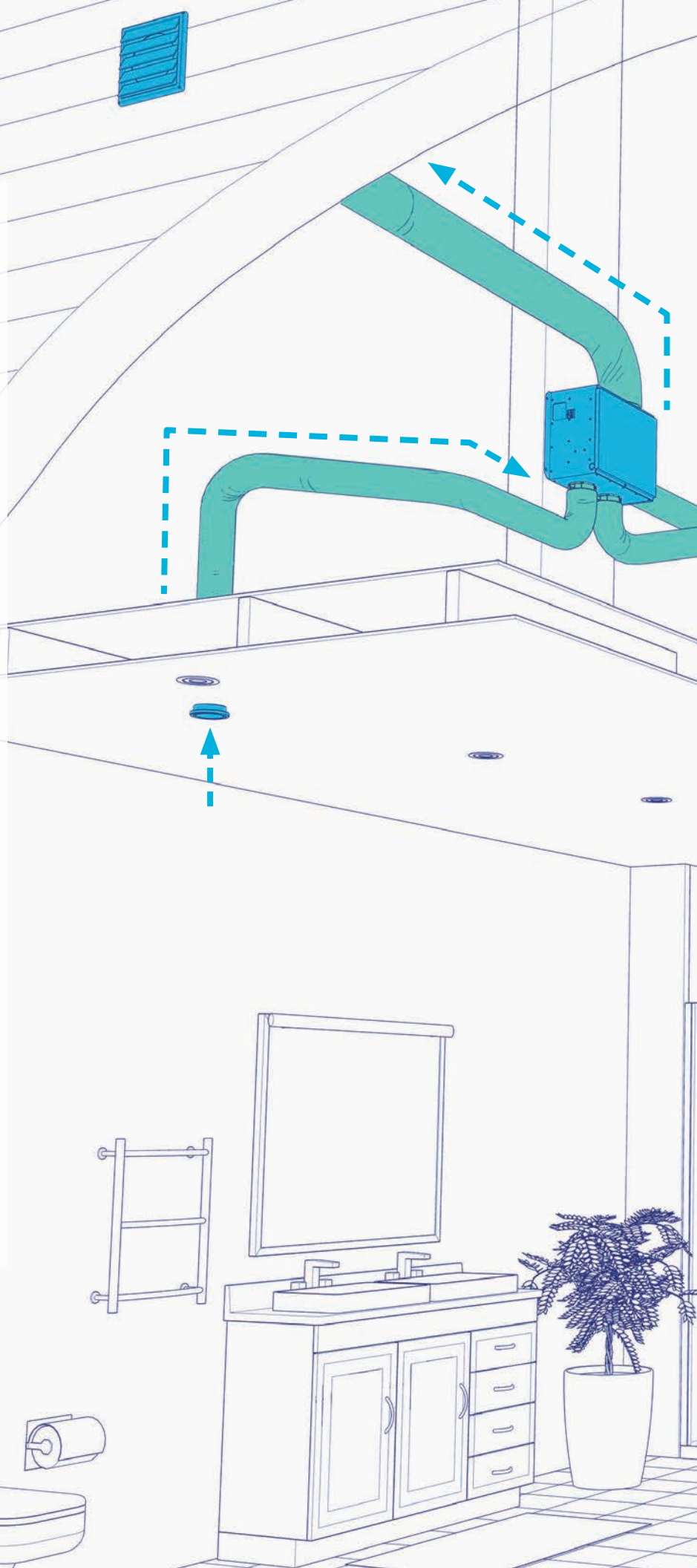

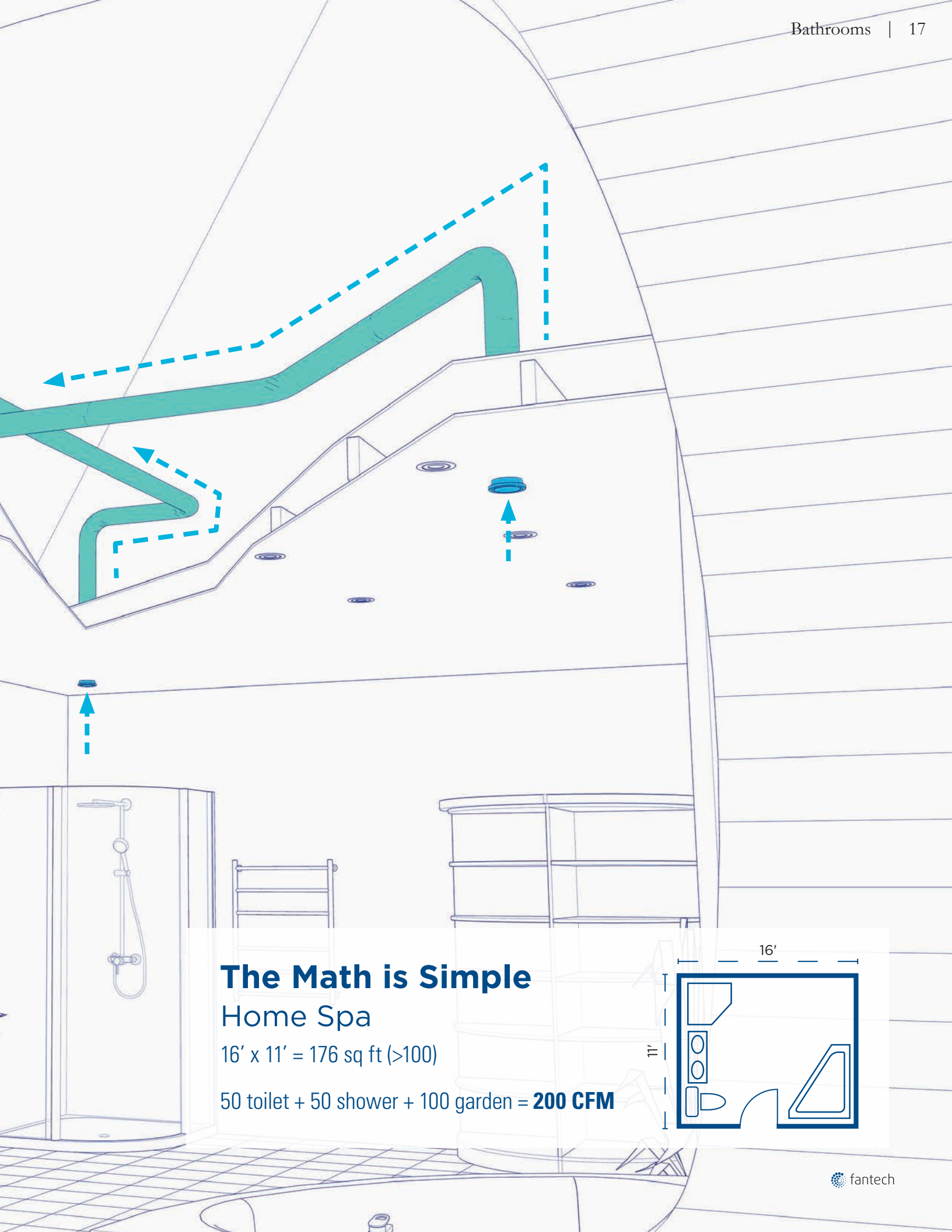

The Math is Simple

Home Spa

$$16' \times 11' = 176 \text{ sq ft } (>100)$$

$$50 \text{ toilet} + 50 \text{ shower} + 100 \text{ garden} = \mathbf{200 \text{ CFM}}$$

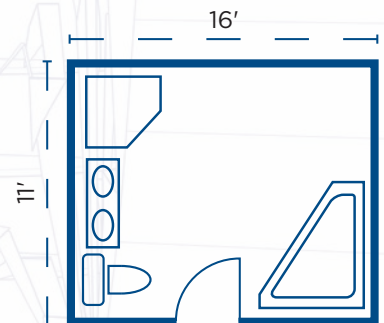

PRO™ Series

Built for the Pro in mind

Efficiency, quiet operation and ease of installation characterize both the PRO™ and PRO™ PLUS series. Both fans are certified to the rigorous California Title 24 building energy code, as well as ETL/c-ETL, HVI, and Energy Star standards. The PRO™ Series operates at just 2.0 sones while the PRO PLUS™ is barely audible at 0.5 sones. Installation is fast and easy thanks to an adjustable mounting bracket that requires fewer screws than other brands.

PRO™ Series (80, 100, & 150)

with a Ceiling Grille

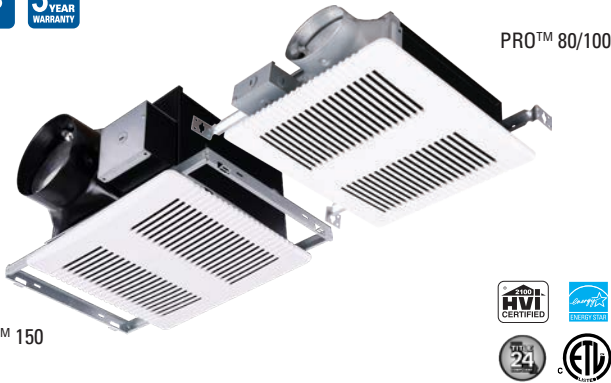

PRO™ PLUS Series

with LED Ceiling Grille, Humidity and Motion Sensor



PRO™ Series offers three models with a ceiling grille and damper for airflow of 80, 100 or 150 cfm. The PRO™80 fan has a unique plug and play concept that allows you to add accessories such as a humidity sensor without changing the fan. This model holds an ETL listing and conforms to UL and CSA safety standards. ENERGY STAR® and HVI qualified, California Title 24 Listed.

Contractor packs are available. See next page for details. Item #98500, #98501, and #98598. Shipping weight 9 lbs.

User-adjustable 80/90/110/140 cfm fan with a ceiling grille, backdraft damper, humidity and motion sensor. The fan provides 4 different airflows: 80-90-110-140 cfm. Uses a 6" flexible duct. The product is provided with an adjustable 12-24" bar hanger for ease of installation. This model holds an ETL listing and conforms to UL and CSA safety standards. ENERGY STAR® and HVI qualified, California Title 24 Listed.

Item #98506 and #98507. Shipping weight 12 lbs.

PRO™ Series Accessories



PRO™ Ceiling Radiation Damper



PRO™ Series LED Light Grille



PRO™ PLUS Ceiling Radiation Damper



PRO™ Series Humidity Sensor

PRO™ Series Features Checklist

Model	Low Sones	Integrated Backdraft Damper	Accessories Sold Separately	Warranty	Integrated LED Light	Integrated Motion Sensor	Integrated Humidity Sensor
PRO™ Series 80 & 100		✓	✓	3 yr			
PRO™ Series 150		✓	✓	3 yr			
PRO™ Plus	✓	✓		5 yr		✓	✓
PRO™ Plus -L	✓	✓		5 yr	✓	✓	✓

PRO™ Series Contractor Packs

Two is one and one is none.

A contractor pack is a great way for professionals to always have what they need on hand for multiple jobs at a time. Each contractor pack contains Rough-in and Trim Kits for **4** PRO™ Series 80/100 Bath Fans.





Customer Support:
USA 800.747.1762 • USsupport@fantech.net
CANADA 800.565.3548 • CANADAsupport@fantech.net

Distributed Locally by:

Systemair Inc. reserves the right to modify, at any time and without notice, any or all of its products' features, designs, components and specifications to maintain their technological leadership position. The application rendering presented in this brochure is for a visual presentation purpose only. Please, contact a professional for technical guidance.

Zephyr Creative • October 2021 • E1575