

## Installation and Operating Instructions - Model 120

### 1. Safety



*Before installing verify compatibility to the process media and temperature in contact with the wetted parts. Incompatible media and / or operation at temperature extremes can cause premature degradation of materials which could result in safety risk to personnel.*

*Verify the selected pressure range (differential pressure and working pressure) and the switch ratings are within specification for your application.*

*The Model 120 Series product utilizes a piston design which inherently has a small amount of leakage from high process connection to low process (15 SCFH air max at 100 PSID) connection. Do not use this product in an application with the low side process connection left open to atmosphere.*

**Warning! Remaining media may result in a risk to personnel, environment etc. Use sufficient precautionary measures when removing and transporting the product.**

**1.1 Intended use:** The indicating / non-indicating differential pressure switches are used for monitoring differential pressures in industrial applications. The manufacturer shall not be liable for any claims if the product is used in applications contrary to the intended use.

**1.2 Personnel:** Personnel installing and putting this instrumentation into service shall be suitably trained and qualified in accordance with local codes, practices and regulations.

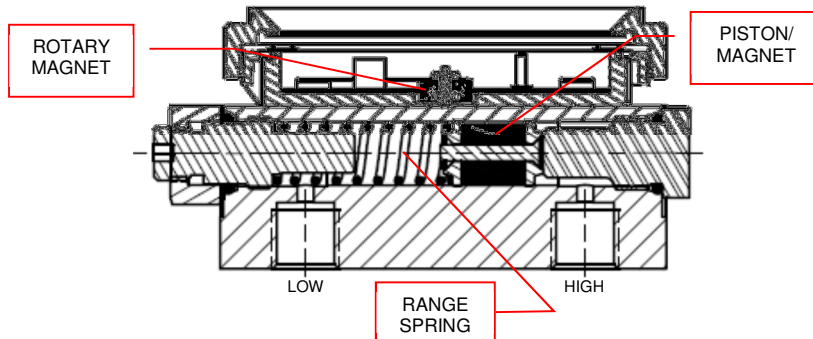

### PRODUCT DESCRIPTION

The Model 120 Series "Filter Minder"<sup>®</sup> is a rugged, medium-range differential pressure instrument available as a switch, a gauge, or both. See "Part Numbering System" for available options

Differential pressure is sensed by the movement of a floating piston magnet against a calibrated spring. The magnetically coupled gauge pointer outside the pressure housing follows the movement of the piston magnet and indicates differential pressure on the dial scale.

When equipped with switches, a contact is made or broken by the magnetic field of the piston magnet. See Bulletin ELECIM120 Series/latest for gauges with switches.

The unit provides full over-range protection to the rated working pressure of the housing in either direction.

### INSPECTION

Before installation check the product label on each instrument against the receiving paperwork and the intended application for correct part number, materials of construction, working pressure, dial range, etc. If equipped with switches, check electrical rating, type of enclosure, etc. Inspect for shipping damage and, report it immediately.

**NOTE - Before attempting repairs contact your local Mid-West Representative or our factory. Failure to do so will void any warranty.**

# Installation and Operating Instructions - Model 120

## INSTALLATION

Model 120 Series "Filter Minder"® is calibrated and tested prior to shipment and is ready for immediate installation. Use of the following installation procedures should eliminate potential damage and provide optimum trouble-free operation.

### 1. CONNECTIONS

¼" FNPT are provided as standard but check paperwork for connections ordered. There are two connections on the housing identified as "HI" and "LO" for high pressure and low pressure (Fig. 2). Be sure these get plumbed to the proper connections on your system. Improper connection will not damage the instrument, but it will not function properly. Flexible tubing is recommended to minimize the effect of any vibration that may exist.

### 2. INSTRUMENT LOCATION

It is recommended that installation is no closer than one inch of a steel surface otherwise accuracy will be affected. On liquid service the instrument should be mounted **below** the process connections to facilitate self-bleeding. On gas service it should be located **above** the process connections to promote self-draining. If the process contains particulates, a "pigtail" loop or drop leg (manometer "U-tube" configuration) in the tubing will minimize the possibility of it migrating into the instrument.

### 3. PANEL MOUNTING

Refer to the table in Figure 1 below for panel mount diagrams, dimensions, and options.

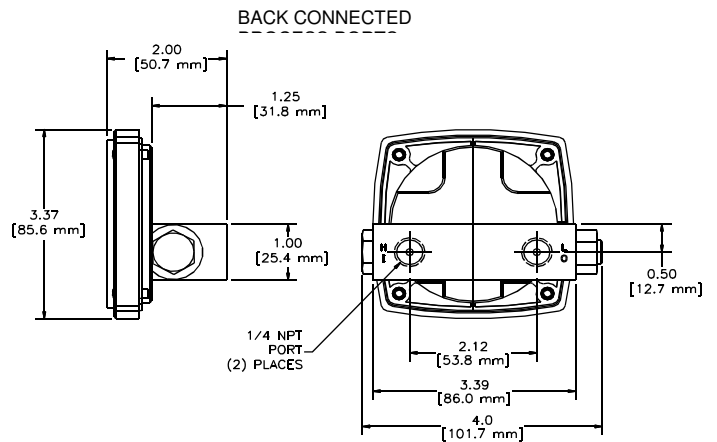

### 4. PIPE MOUNTING

An optional pipe mounting kit is available for mounting the gauge to a 2" vertical or horizontal pipe. Refer to drawing below pipe mount diagrams and dimensions.

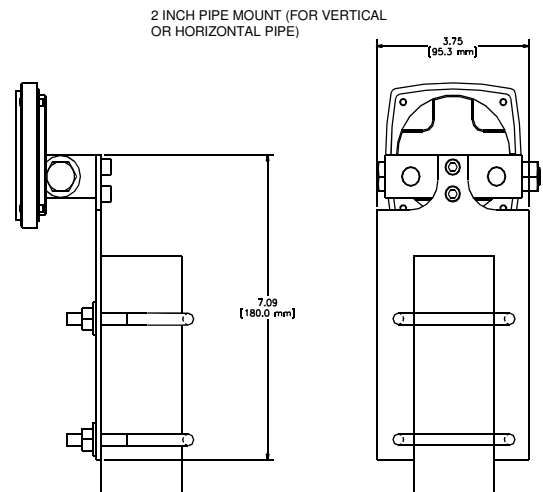

MODEL 120 PANEL CUT-OUT DIMENSIONS

DIAL SIZE	DIAMETER A Inch (mm)	DIAMETER C Inch (mm)	DIAMETER H Inch (mm)
2-1/2 in.	3.00 (76.2)	3.50 (88.9)	0.19 (4.7)
4-1/2 in.	5.30 (134.6)	5.63 (143.0)	0.19 (4.7)
6 in.	6.50 (165.1)	7.00 (177.8)	0.19 (4.7)

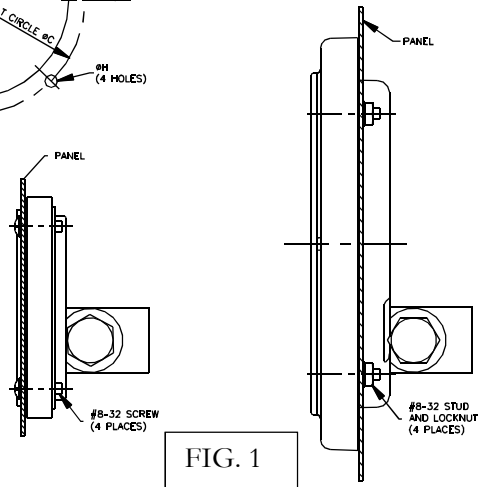
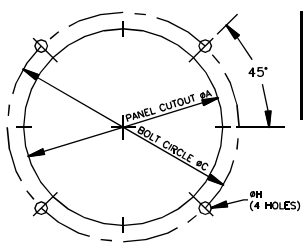

## TROUBLE SHOOTING

### 1. Gauge does not indicate differential

- Check for proper hook up, high to "HI" and low to "LO"
- Make certain block valves are open and, if using a 3-valve manifold, that the equalizer (balance) valve is closed.
- If a & b check out correctly, loosen or disconnect the high pressure line to determine if there is pressure to the instrument.
- If there is pressure to the instrument, check to determine that there is differential across the unit being monitored. If so, contact the factory for assistance and/or an "RGA" (return goods authorization) number to return the instrument for repair or replacement