



200 SERIES
Indoor Applications,
Insulated or Non-Insulated



9200 SERIES
Heavy duty, Insulated Indoor
or Outdoor Applications



9200-VIB SERIES
With Internal Spring Vibration Isolation



Call for pricing & availability.

200, 9200 & 9200-VIB SERIES

Single & Twin Forward Curved Inline Duct Blowers

- As part of an HVAC system Delhi Duct Blowers will not “surge”, “hunt”, or “stall”.
- Optional variable pitch motor pulley permits field adjustment (typically + or - 15%) to match air delivery needs.
- For the quietest operational needs we offer optional internal spring isolation of the blower/motor from the housing thus greatly reducing radiated cabinet noise (9200-VIB only).
- Our twins (two duct blowers on a common shaft) is a wide but not tall solution for situations where vertical space is limited.
- Quiet forward curved blowers operate at ½ the rpm of other inline solutions.
- An outdoor series, 9200, is available.

INDUSTRIES SERVED

- Commercial HVAC
- Ventilation
- Heating
- Cooling
- Construction



Canarm certifies that the 200 & 9200 Series shown herein are licensed to bear the AMCA Seal. The ratings shown are based on tests and procedures performed in accordance with AMCA Publications 211 & 311 and comply with the requirements of the AMCA Certified Ratings Programme.

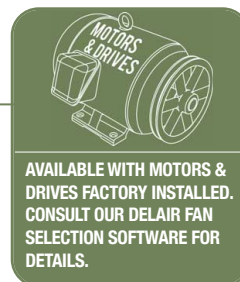

FEATURES

- **Wheel Diameters:** 7” through 20”
- **CFM:** Approximately 500 to 12,500 CFM in a single blower (Twins available).
- **Static Pressure:** Usage to about 3” static pressure is common, although allowable range is higher.
- Constructed from cold rolled steel, with green baked on powder coat. The outdoor unit uses protective galvaneal steel under the powder coat.
- Forward Curved blowers operate at low RPM for low noise levels.
- Heavy duty ball bearings suitable for -65° F to +250° F.
- Keywayed shafts both ends for clockwise or counter clockwise rotation.
- Saddle type motor mounting platform provides extended belt tension adjustment range on all models.
- 9200 series may be mounted vertically or horizontally. VIB option is horizontal mount only. Cannot be vertically mounted.

Twin Units (not illustrated) use a common shaft for balanced air supply by each blower.

PERFORMANCE SPECIFICATIONS

CFM values listed right are summarized for convenience. For full performance data refer to our Delair program.

Power rating (BHP) does not include transmission losses. Performance certified is for installation type B: Free inlet, Ducted outlet. Performance ratings do not include the effect of appurtenances (accessories).

MODEL	TYPICAL MAXIMUM CFM @ SP						Min HP	Max HP
	1/2" SP	1" SP	1 1/2" SP	2" SP	2 1/2" SP	3" SP		
207	1400	1250	1100	900	700	1/6	3/4	
209	1800	1600	1400	1100	800	1/6	3/4	
9209	2400	2300	2100	1900	1700	1/6	1 1/2	
210	2900	2700	2500	2100	1700	1/6	1 1/2	
9210	2900	2700	2500	2100	1700	1/6	1 1/2	
212	3600	3200	2800	2300	1800	1/6	1 1/2	
9212	4900	4500	4100	3800	3500	1/6	3	
215	5700	5200	4600	4000	3400	1/3	3	
9215	7200	6700	6200	5700	5200	1/3	5	
218 & 9218	9000	8250	7500	6700	5750	1/2	5	
9220	15800	15100	14500	13800	13000	3/4	15	

*CONSULT OUR DELAIR SOFTWARE FOR FAN CURVES & PERFORMANCE DATA. DOWNLOAD DELAIR @ WWW.CANARM.COM/DELAIR

TYPICAL APPLICATIONS FOR OUR INLINE BLOWERS

- An Inline make-up air solution for cases where a rooftop curb mounted solution is not available.
- As an air moving module for systems built up with other components such as heating/cooling coils.
- Noise sensitive areas - the low rpm forward curved wheel typically radiates less vibration than higher rpm backward inclined wheel solutions.
- When the application requires an air mover in a duct system located in a ceiling space.
- Redistribution or recirculation of air in a work space.
- Interlocked with entry doors to prevent entry of cold outdoor air into retail sales space and thus greets customers with warmth.
- Bathroom/ rest room exhaust - one duct blower serving multiple intakes.



IDB, IDB-X, 200, 9200 & 9200-VIB SERIES

Single & Twin Forward Curved Inline Duct Blowers



Twin unit available for 200, 9200, 9200-VIB models
Call for pricing & availability.

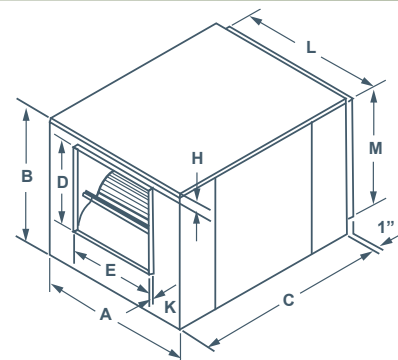
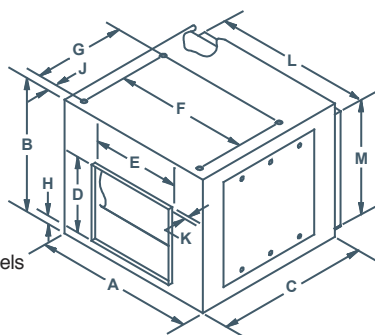

DIMENSIONS

MODEL	A	B	C	OUTLET							INLET		SHAFT DIAMETER	UNIT WEIGHT (LBS) (without motor)
				D	E	F	G	H	J	K	L	M		
IDB07 / IDB-X / 207	18"	15.375"	23"	8 1/4"	9 3/16"	14 1/2"	9 5/8"	1 1/4"	1 1/4"	7/8"	15 7/8"	13 3/8"	3/4"	43
IDB09 / IDB-X / 209	21"	18"	23"	10 1/4"	11 13/16"	17 1/2"	11 3/4"	1 1/4"	1 3/4"	7/8"	19"	16"	3/4"	55
IDB10 / IDB-X / 210	22.25"	20"	24 3/4"	11 3/8"	13 1/8"	18 3/4"	13 3/8"	1 1/4"	1 3/4"	7/8"	20 1/4"	18"	3/4"	65
IDB12 / IDB-X / 212	27"	23"	27 1/2"	13 7/16"	15 5/8"	23 1/2"	16 1/8"	1 1/4"	1 3/4"	7/8"	25"	21"	3/4"	82
IDB15 / IDB-X / 215	33.5"	28"	32"	15 7/8"	18 5/8"	28"	19 1/2"	2 5/8"	1 3/4"	7/8"	30 1/2"	25"	1"	140
218	41.5"	34"	44"	19 5/8"	22 5/8"	35"	24"	2 3/4"	1 3/4"	1 1/8"	35 3/8"	31 5/8"	1"	158
9209	21"	18"	23"	11 1/4"	12 3/4"	N/A	N/A	1"	N/A	1 1/8"	19"	16"	3/4"	61
9210	22 1/4"	20"	24 3/4"	12 3/8"	14 1/8"	N/A	N/A	1"	N/A	1 1/8"	20 1/4"	18"	3/4"	70
9212	30 1/8"	24 3/4"	34"	14 1/2"	16 5/8"	N/A	N/A	2 1/8"	N/A	1 1/8"	25 1/8"	21 1/8"	1"	143
9215	33 3/4"	28 5/8"	38 1/8"	17"	19 5/8"	N/A	N/A	2 1/8"	N/A	1 1/8"	30 5/8"	25 1/4"	1"	176
9218	41 1/2"	34"	44"	19 5/8"	22 5/8"	N/A	N/A	2 3/4"	N/A	1 1/8"	35 3/8"	31 5/8"	1"	323
9220	44 3/4"	41 1/8"	57 1/2"	25 3/4"	25 3/4"	N/A	N/A	3"	N/A	1 1/8"	38 3/8"	35 1/8"	1 7/16"	515

ACCESSORIES

- Filter sections
- Intake Hoods
- External Vibration Isolators
- Hot Water Coils
- Chilled Water Coils

FILTER SECTIONS & INTAKE HOODS

Series F200A, F9200A & H9200

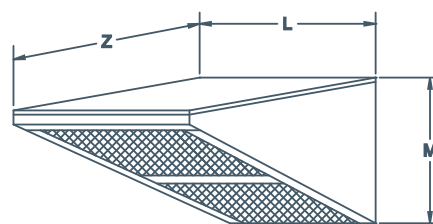
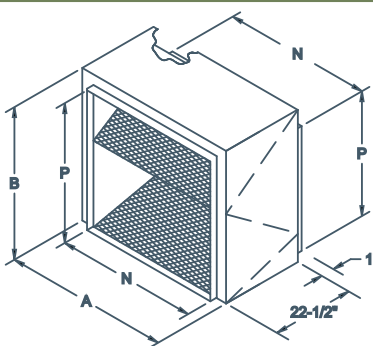
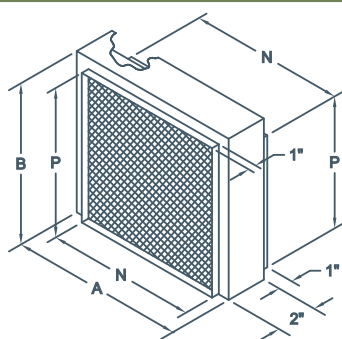

F200A FILTER SECTION
For IDB, IDB-X, 200 & 9200 Series
Duct Blowers

F9200A FILTER SECTION
For Model 9200 Duct Blowers

H9200 INTAKE HOOD
For 9200 Series Duct Blowers

MODEL	A	B	N	P	FILTER		UNIT WEIGHT (LBS)
					SIZE	QUANTITY	
F207A	17 3/4"	15 3/8"	16"	13 1/2"	14 1/8" X 16 5/8"	1	11
F209A	21"	18"	19 1/8"	16 1/8"	16 3/4" X 19 7/8"	1	12
F210A	22 1/4"	20"	20 3/8"	18 1/8"	18 3/4" X 21 1/8"	1	14
F212A	27"	23"	25 1/8"	21 1/8"	21 3/4" X 25 7/8"	1	16
F215A	32 1/2"	26 3/4"	30 5/8"	25 1/8"	25 3/4" X 31"	1	21
F218A	37"	33 1/4"	35 1/4"	31 1/2"	32 1/4" X 35 7/8"	1	46
F9220A	39 3/4"	37 1/4"	38 1/2"	35 1/4"	20" X 25"	6	64

MODEL	L	M	Z	FILTER		UNIT WEIGHT (LBS)
				SIZE	QUANTITY	
H9209	19 1/4"	16 9/16"	21 1/4"	16" X 24"	1	14
H9210	20 1/2"	18 9/16"	25 3/4"	15" X 20"	2	16
H9212	25 3/8"	21 9/16"	30 3/4"	20" X 25 & 16" X 25"	2	27
H9215	31 3/16"	25 13/16"	33 1/2"	20" X 28 1/2"	2	38
H9218	35 5/8"	32 11/16"	40 1/4"	20" X 25 (2) & 16" X 25"	3	50
H9220	38 5/8"	35 9/16"	22"	FILTERS NOT INCLUDED USE F9220A		40