

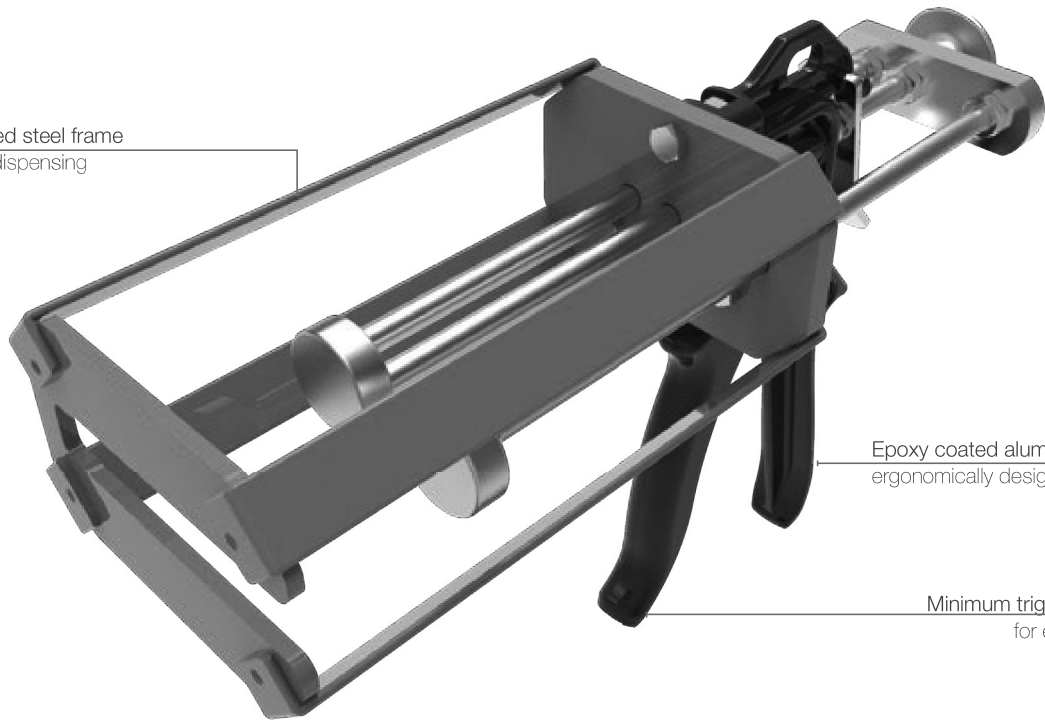

VBM 200X MR

200mL Cartridge Dispenser

Epoxy coated steel frame
for efficient dispensing



Epoxy coated aluminum handle
ergonomically design for comfort

Minimum trigger pressure
for effortless use

Model shown: VBM 200X MR 200mL

Features

- High quality cast aluminum handle
- Epoxy coated steel frame support
- Sintered alloy catch plate
- Snap fit cartridge strap
- Customization possible

Benefits

- For day long comfortable use
- For efficient dispensing
- Wear compensation device (WCD)
- For optimal cartridge support
- Customer labelling

Applications



Bonding



Sealing



Shimming

Product by range



The **VBM 200 MR** 2-component multi ratio manual dispenser has a high-powered 18:1 mechanism with epoxy coated steel frame and wear compensation device.

Specifications

- Lightweight: 1.5kg / 3.3lbs
- Frame Length: 166mm / 4.5in
- Maximum Thrust: 3.5kN
- Handle Material: Epoxy Coated Aluminum
- Frame Material: Epoxy Coated Steel
- Tool Component Approvals: REACH
- Cartridge Capacity: 200mL / 7.0oz
- Cartridge Ratio: 1:1, 2:1, 4:1, 10:1
- Mechanical Advantage Ratio: 18:1
- Viscosity: Medium / High
- Standard Color: Black / Blue
- Customized Versions: Yes

Dimensions

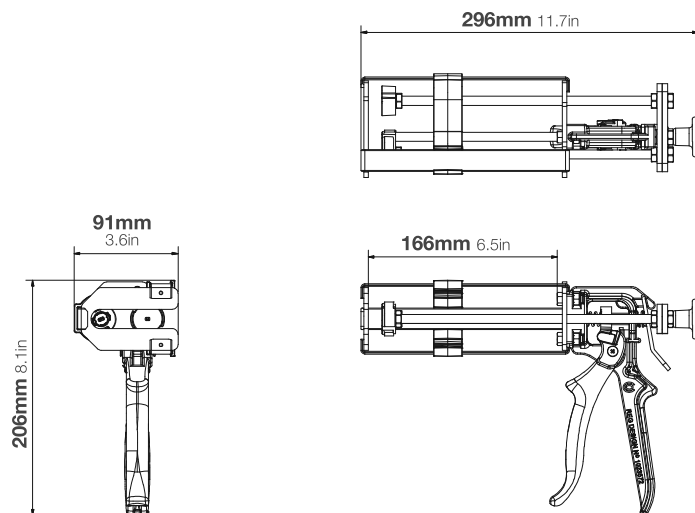

Part number:

DM2C 200-MR-r18-101

Article number:

167324 / M200MR (US)

Packaging:

10 per Box / 1 per Box (US)

Matching MIXPAC™ side-by-side cartridges



C-System / F-System
200mL / 1:1 PP/PA/PBT



C-System / F-System
200mL / 2:1 PP/PA



C-System / F-System
200mL / 4:1 PP/PBT



C-System / F-System
200mL / 10:1 PP/PBT

Compatible side-by-side cartridges

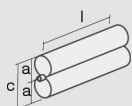

Plastic Cartridge
200mL / 1:1 PP/PBT

| 1:1 | mm | inch |
|-----|-------|-------|
| l | 148.0 | 5.83 |
| a | Ø37.0 | Ø1.46 |
| c | 79.0 | 3.11 |

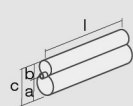

Plastic Cartridge
200mL / 2:1 PP

| 2:1 | mm | inch |
|-----|-------|-------|
| l | 148.0 | 5.83 |
| a | Ø50.0 | Ø1.97 |
| b | Ø31.0 | Ø1.22 |
| c | 81.0 | 3.19 |

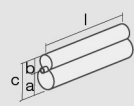

Plastic Cartridge
200mL / 4:1 PP/PBT

| 4:1 | mm | inch |
|-----|-------|-------|
| l | 148.0 | 5.83 |
| a | Ø49.0 | Ø1.93 |
| b | Ø25.0 | Ø0.98 |
| c | 77.0 | 3.03 |

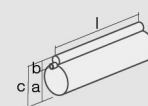

Plastic Cartridge
200mL / 10:1 PP/PBT

| 10:1 | mm | inch |
|------|-------|-------|
| l | 147.0 | 5.79 |
| a | Ø55.0 | Ø2.17 |
| b | Ø19.0 | Ø0.75 |
| c | 78.0 | 3.07 |

Conversion kits

Conversion kit included

Matching accessories

-



VBM 200 MR

200mL Cartridge Dispenser

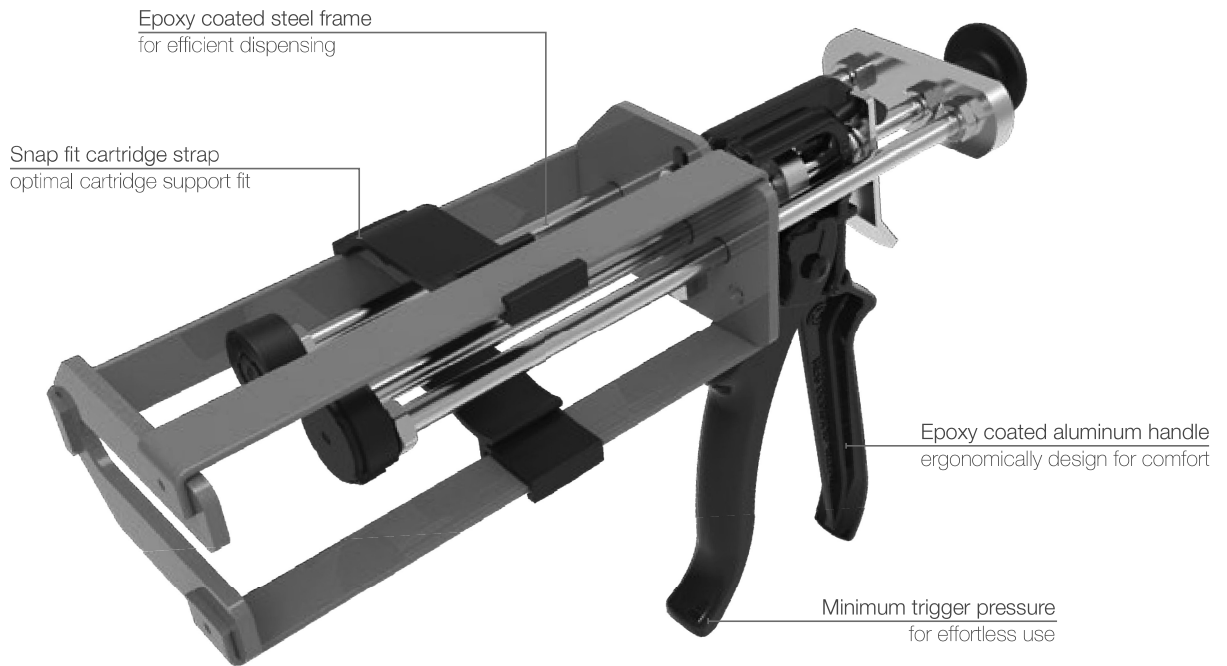

Sulzer | 2-Component COX Dispenser | 50

Model shown: VBM 200 MR 200mL

Features

- High quality cast aluminum handle
- Epoxy coated steel frame support
- Sintered alloy catch plate
- Snap fit cartridge strap
- Customization possible

Benefits

- For day long comfortable use
- For efficient dispensing
- Wear compensation device (WCD)
- For optimal cartridge support
- Customer labelling

Applications

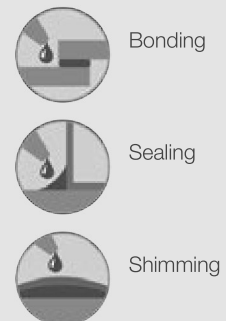

Product by range



The **VBM 100** 2-component manual dispenser has a high-powered 18:1 mechanism designed for use with low to medium viscosity sealants and adhesives.

Specifications

- Lightweight: 1.2kg / 2.6lbs
- Frame Length: 166mm / 6.5in
- Maximum Thrust: 3.5kN
- Handle Material: Epoxy Coated Aluminum
- Frame Material: Epoxy Coated Steel
- Tool Component Approvals: REACH
- Cartridge Capacity: 200mL (7.0oz)
- Cartridge Ratio: 1:1 / 2:1
- Mechanical Advantage Ratio: 18:1
- Viscosity: Low / Medium
- Standard Color: Black / Blue
- Customized Versions: Yes

Dimensions

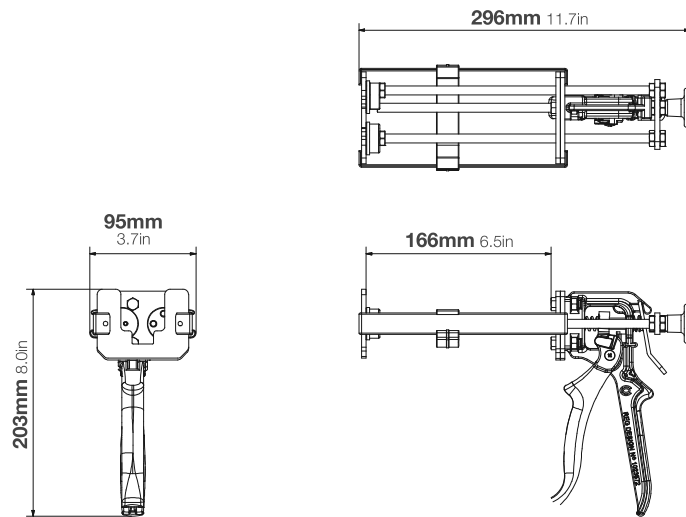

Part number:

DM2C 200-01-r18-101

Article number:

159900 / M100 (US)

Packaging:

10 per Box / 1 per Box (US)

Matching MIXPAC™ side-by-side cartridges

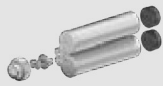

C-System / F-System
200mL / 1:1 PP/PA



C-System / F-System
200mL / 2:1 PP/PA

Compatible side-by-side cartridges

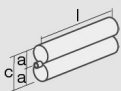

Plastic Cartridge
200mL / 1:1 PP

| 1:1 | mm | inch |
|-----|-------|-------|
| l | 148.0 | 5.83 |
| a | Ø37.0 | Ø1.46 |
| c | 79.0 | 3.11 |

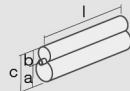

Plastic Cartridge
200mL / 2:1 PP

| 2:1 | mm | inch |
|-----|-------|-------|
| l | 148.0 | 5.83 |
| a | Ø50.0 | Ø1.97 |
| b | Ø31.0 | Ø1.22 |
| c | 81.0 | 3.19 |

Conversion kits

Matching accessories



VBM 100

200mL Cartridge Dispenser

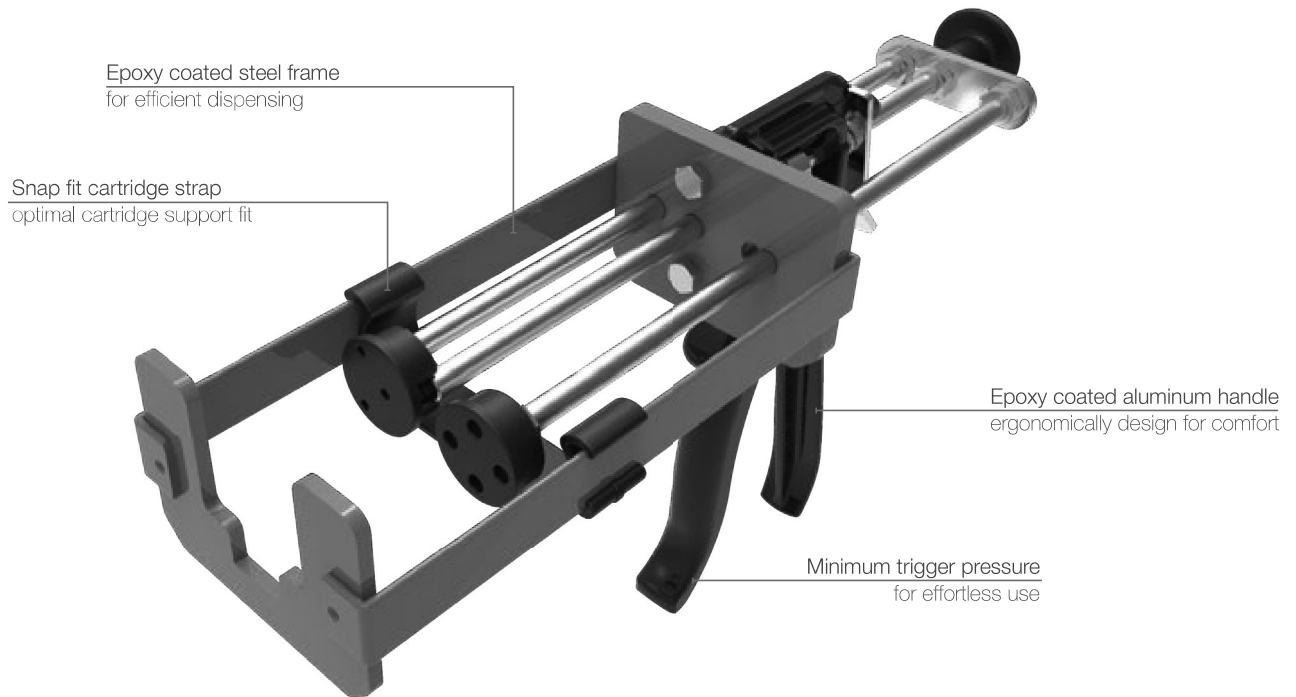

Model shown: VBM 100 200mL

Features

- High quality cast aluminum handle
- Epoxy coated steel frame support
- Sintered alloy catch plate
- Snap fit cartridge strap
- Customization possible

Benefits

- For day long comfortable use
- For efficient dispensing
- Wear compensation device (WCD)
- For optimal cartridge support
- Customer labelling

Applications



Bonding



Sealing



Shimming

Product by range



The **RBM 585X** 2-component manual dispenser has a high-powered 25:1 mechanism with epoxy coated steel frame allows for higher volume and repetitive applications.

Specifications

- Lightweight: 1.2kg / 2.6lbs
- Frame Length: 264mm / 10.4inch
- Maximum Thrust: 3.5kN
- Handle Material: Epoxy Coated Aluminum
- Frame Material: Epoxy Coated Steel
- Tool Component Approvals: REACH
- Cartridge Capacity: 585mL (20.6oz)
- Cartridge Ratio: 3:1
- Mechanical Advantage Ratio: 25:1
- Viscosity: High
- Standard Color: Black / Blue
- Customized Versions: Yes

Dimensions

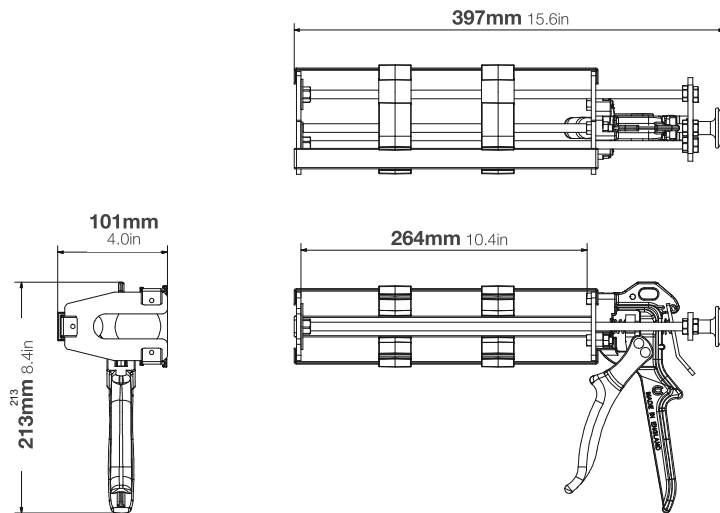

Part number:

DM2C 585-03-r25-001

Article number:

177827

Packaging:

10 per Box

Matching MIXPAC™ cartridges

Compatible side-by-side cartridges

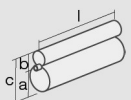

Plastic Cartridge
385mL / 3:1 PP

| 3:1 | mm | inch |
|-----|-------|-------|
| l | 171.0 | 6.73 |
| a | Ø54.4 | Ø2.14 |
| b | Ø32.6 | Ø1.28 |
| c | 90.0 | 3.54 |

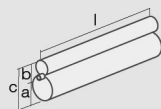

Plastic Cartridge
585mL / 3:1 PP

| 3:1 | mm | inch |
|-----|-------|-------|
| l | 244.0 | 9.61 |
| a | Ø54.4 | Ø2.14 |
| b | Ø32.6 | Ø1.28 |
| c | 90.0 | 3.54 |

Conversion kits

Matching accessories



RBM 585X

585mL Cartridge Dispenser

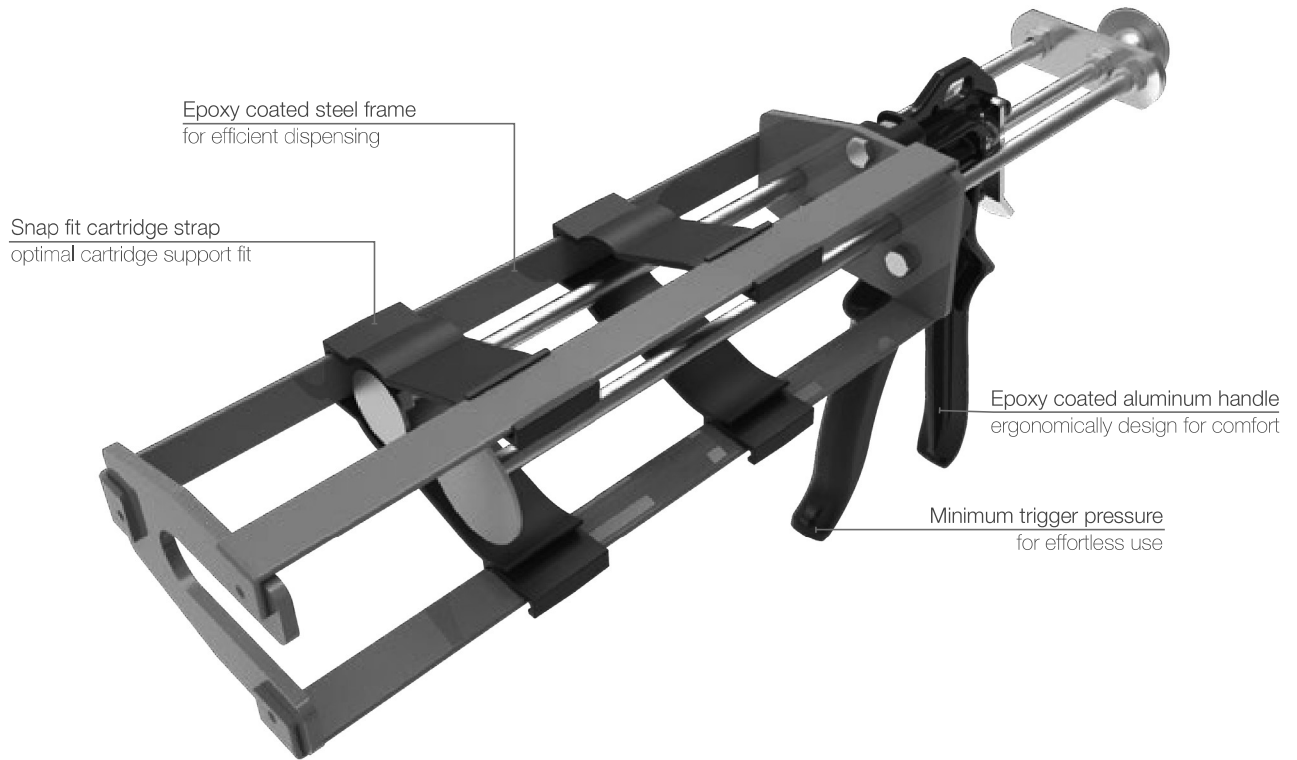

Model shown: RBM 585X 585mL

Features

- High quality cast aluminum handle
- Epoxy coated steel frame support
- Sintered alloy catch plate
- Snap fit cartridge strap
- Customization possible

Benefits

- For day long comfortable use
- For efficient dispensing
- Wear compensation device (WCD)
- For optimal cartridge support
- Customer labelling

Applications



Product by range

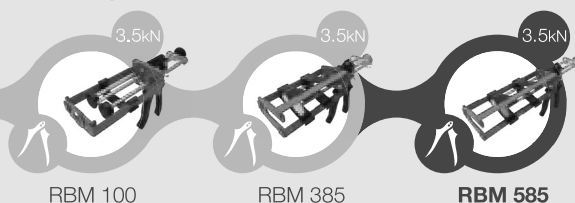

The **RBM 385X** 2-component manual dispenser has a high-powered 25:1 mechanism designed for use with high viscosity sealants and adhesives.

Specifications

- Lightweight: 1.2kg / 2.6lbs
- Frame Length: 194mm / 7.6in
- Maximum Thrust: 3.5kN
- Handle Material: Epoxy Coated Aluminum
- Frame Material: Epoxy Coated Steel
- Tool Component Approvals: REACH
- Cartridge Capacity: 385mL (13.6oz)
- Cartridge Ratio: 3:1
- Mechanical Advantage Ratio: 25:1
- Viscosity: High
- Standard Color: Black / Blue
- Customized Versions: Yes

Dimensions

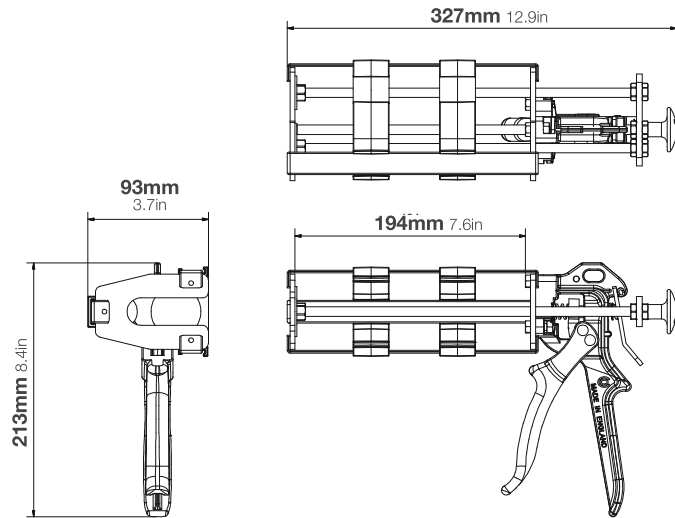

Part number:

DM2C 385-03-r25-001

Article number:

177829

Packaging:

10 per Box

Matching MIXPAC™ side-by-side cartridges

Compatible side-by-side cartridges

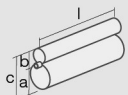

Plastic Cartridge
385mL / 3:1 PP

| 3:1 | mm | inch |
|-----|-------|-------|
| l | 171.0 | 6.73 |
| a | Ø54.4 | Ø2.14 |
| b | Ø32.6 | Ø1.28 |
| c | 90.0 | 3.54 |

Conversion kits

Matching accessories



RBM 385X

385mL Cartridge Dispenser

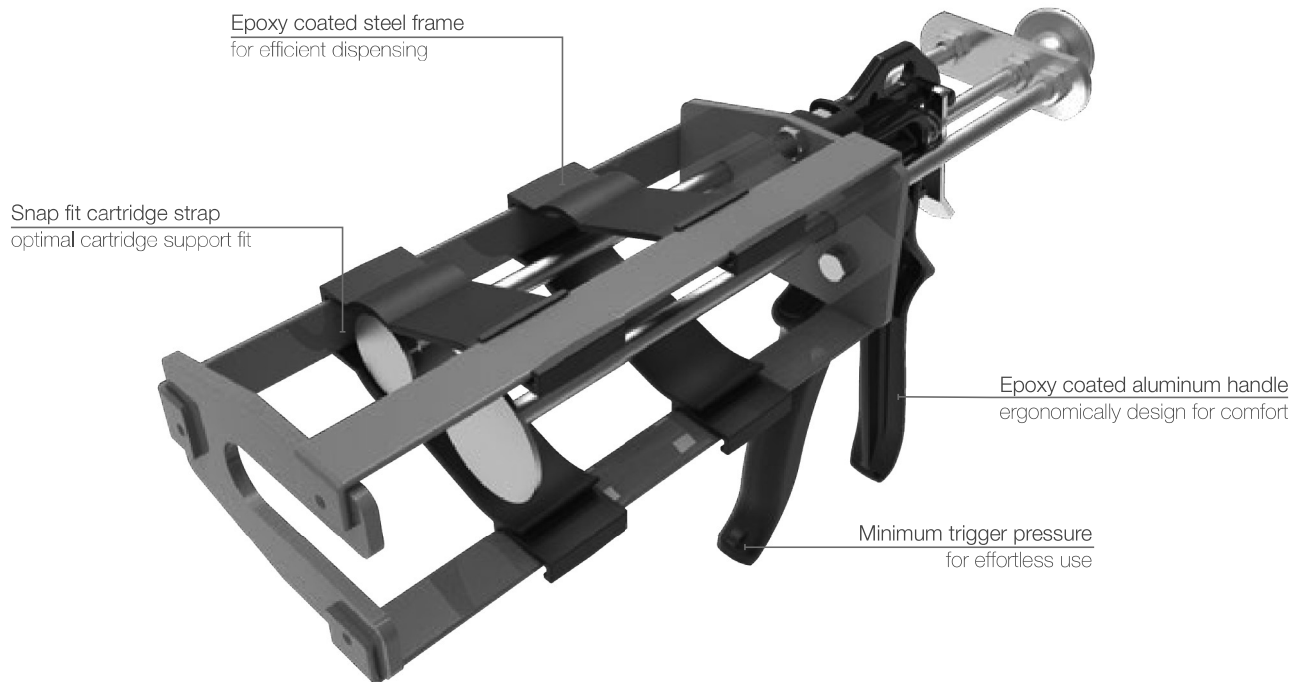

Model shown: RBM 385X 385mL

Features

- High quality cast aluminum handle
- Epoxy coated steel frame support
- Sintered alloy catch plate
- Snap fit cartridge strap
- Customization possible

Benefits

- For day long comfortable use
- For efficient dispensing
- Wear compensation device (WCD)
- For optimal cartridge support
- Customer labelling

Applications



Bonding



Chemical Anchoring



Crack Repair



Sealing



Solid Surface



Repair



Water Proofing

Product by range

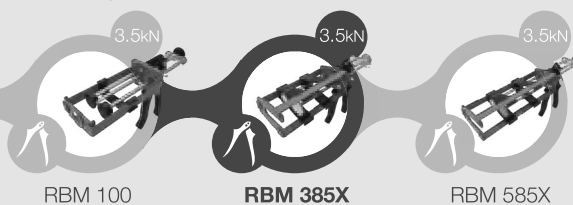

The **RBM 100** 2-component manual dispenser has a high-powered 18:1 mechanism with epoxy coated steel frame and snap fit cartridge straps for optimum support and fit.

Specifications

- Lightweight: 1.2kg / 2.6lbs
- Frame Length: 164mm / 6.5inch
- Maximum Thrust: 3.5kN
- Handle Material: Epoxy Coated Aluminum
- Frame Material: Epoxy Coated Steel
- Tool Component Approvals: REACH
- Cartridge Capacity: 220mL (7.7oz)
- Cartridge Ratio: 1:1
- Mechanical Advantage Ratio: 18:1
- Viscosity: Medium / High
- Standard Color: Black / Blue
- Customized Versions: Yes

Dimensions

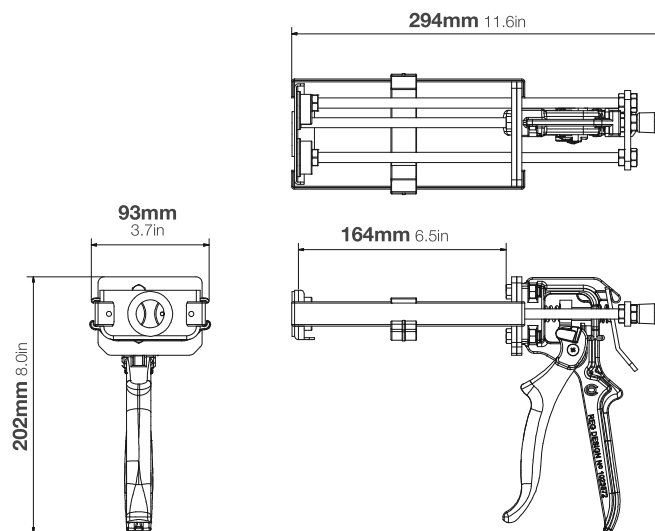

Part number:

DM2C 200-01-r18-201

Article number:

177796

Packaging:

10 per Box

Matching MIXPAC™ cartridges

Compatible side-by-side cartridges

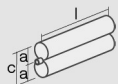

Plastic Cartridge
2x110mL / 1:1 PE

| 1:1 | mm | inch |
|-----|-------|-------|
| l | 144.0 | 5.67 |
| a | Ø37.0 | Ø1.46 |
| c | 76.0 | 2.99 |

Conversion kits

Matching accessories



RBM 100

220mL Cartridge Dispenser

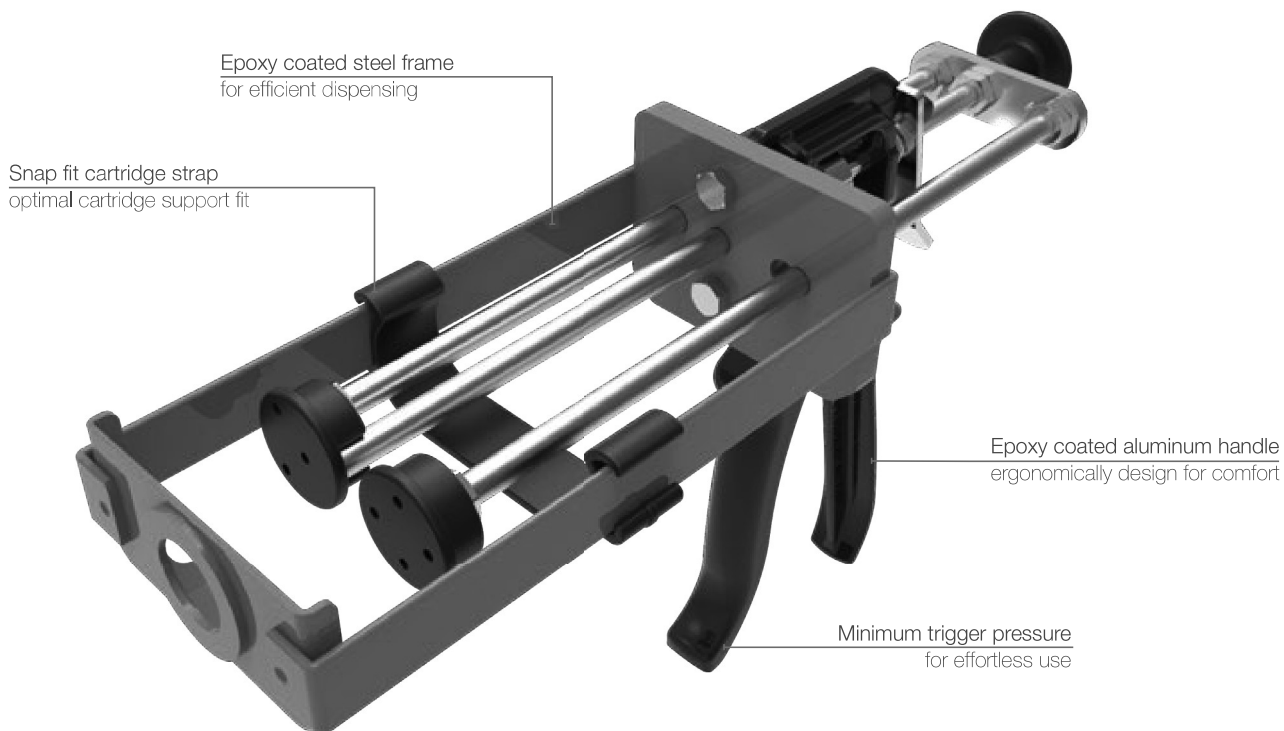

Model shown: RBM 100 220mL

Features

- High quality cast aluminum handle
- Epoxy coated steel frame support
- Sintered alloy catch plate
- Snap fit cartridge strap
- Customization possible

Benefits

- For day long comfortable use
- For efficient dispensing
- Wear compensation device (WCD)
- For optimal cartridge support
- Customer labelling

Applications



Bonding



Sealing



Shimming

Product by range

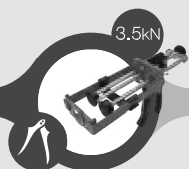

RBM 100



RBM 385



RBM 585

The **CBM 310CP X** 2-component manual dispenser with high-powered 25:1 mechanism and epoxy coated steel frame gives efficient, effortless dispensing for 620mL aluminum cartridges.

Specifications

- Lightweight: 1.5kg / 3.3lbs
- Frame Length: 234mm / 9.2inch
- Maximum Thrust: 4.5kN
- Handle Material: Epoxy Coated Aluminum
- Frame Material: Epoxy Coated Steel
- Tool Component Approvals: REACH
- Cartridge Capacity: 620mL (21.0oz)
- Cartridge Ratio: 1:1
- Mechanical Advantage Ratio: 25:1
- Viscosity: Medium
- Standard Color: Black / Blue
- Customized Versions: Yes

Dimensions

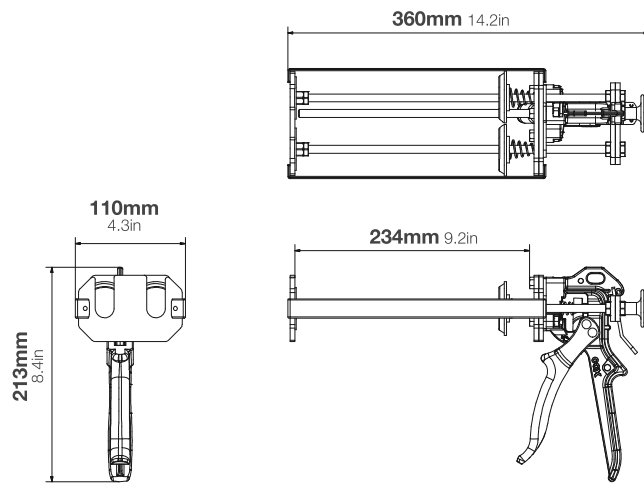

Part number:

DM2C 620-01-r25-201

Article number:

177652

Packaging:

1 per box

Matching MIXPAC™ cartridges

Compatible side-by-side cartridges

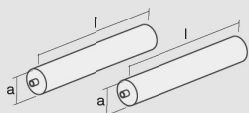

2x 310ml Alu Cartridge
630mL / 1:1 PP

| 1:1 | mm | inch |
|-----|-------|-------|
| l | 215.0 | 8.46 |
| a | Ø79.0 | Ø3.11 |
| c | 160.0 | 6.3 |

Conversion kits

Matching accessories



CBM 310CP X

620mL Cartridge Dispenser

Epoxy coated steel frame
for efficient dispensing



Epoxy coated aluminum handle
ergonomically design for comfort

Model shown: CBM 310CP X 620mL

Features

- High quality cast aluminum handle
- Epoxy coated steel frame support
- Sintered alloy catch plate
- Minimum trigger pressure
- Customization possible

Benefits

- For day long comfortable use
- For efficient dispensing
- Wear compensation device (WCD)
- For effortless use
- Customer labelling

Applications



Bonding



Sealing



Shimming

Product by range



CBM 310/S

CBM 310/XC

CBM 310/CP(X)

The **CBM 310XC** 2-component manual dispenser with high-powered 25:1 mechanism and epoxy coated steel frame is suitable for 620mL aluminum cartridges.

Specifications

- Lightweight: 1.5kg / 3.3lbs
- Frame Length: 233mm / 9.8inch
- Maximum Thrust: 4.5kN
- Handle Material: Epoxy Coated Aluminum
- Frame Material: Epoxy Coated Steel
- Tool Component Approvals: REACH
- Cartridge Capacity: 620mL (21.0oz)
- Cartridge Ratio: 1:1
- Mechanical Advantage Ratio: 25:1
- Viscosity: Medium
- Standard Color: Black / Blue
- Customized Versions: Yes

Dimensions

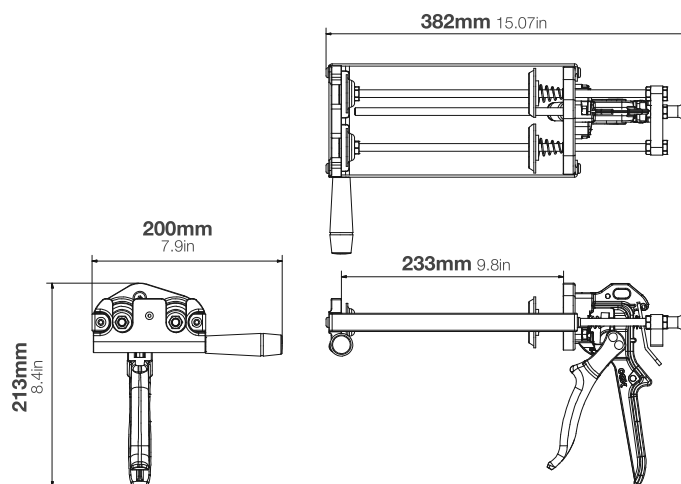

Part number:

DM2C 620-01-r25-101

Article number:

177649

Packaging:

1 per box

Matching MIXPAC™ cartridges

Compatible side-by-side cartridges

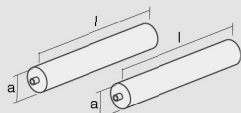

2x 310ml Alu Cartridge
620mL / 1:1 PP

| 1:1 | mm | inch |
|-----|-------|-------|
| l | 215.0 | 8.46 |
| a | Ø79.0 | Ø3.11 |
| c | 160.0 | 6.3 |

Conversion kits

Matching accessories

Connecting manifold supplied for 2x200mL cartridges on page 145.



CBM 310XC

620mL Cartridge Dispenser

Epoxy coated steel frame
for efficient dispensing

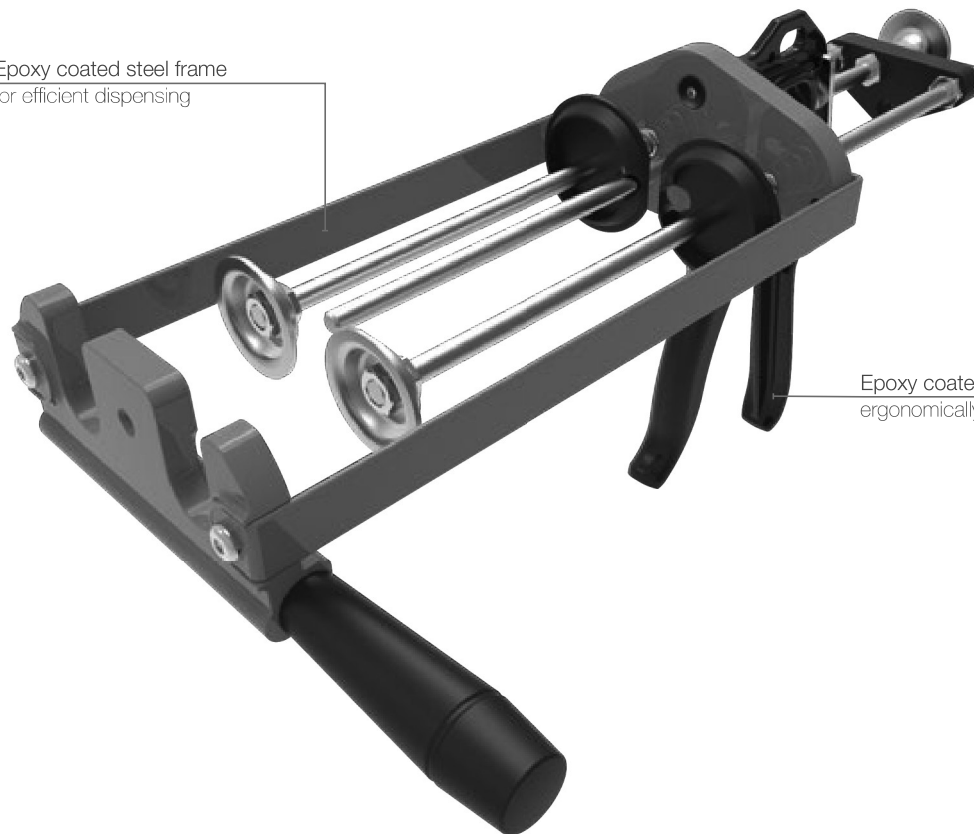

Epoxy coated aluminum handle
ergonomically design for comfort

Model shown: CBM 310XC 620mL

Features

- High quality cast aluminum handle
- Epoxy coated steel frame support
- Sintered alloy catch plate
- Minimum trigger pressure
- Customization possible

Benefits

- For day long comfortable use
- For efficient dispensing
- Wear compensation device (WCD)
- For effortless use
- Customer labelling

Applications



Bonding



Sealing



Shimming

Product by range

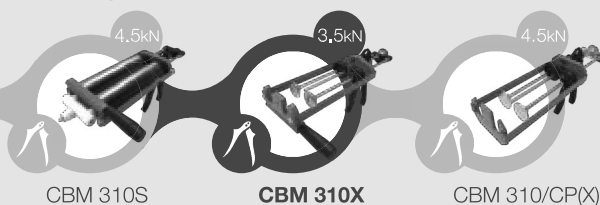

CBM 310S

CBM 310X

CBM 310/CP(X)

The **CBM 310S** 2-component manual dispenser with high-powered 18:1 mechanism and epoxy coated steel frame is suitable for 620mL sachets.

Specifications

- Lightweight: 1.7kg / 3.7 lbs
- Frame Length: 196mm / 7.7inch
- Maximum Thrust: 3.5kN
- Handle Material: Epoxy Coated Aluminum
- Frame Material: Epoxy Coated Steel
- Tool Component Approvals: REACH
- Sachet Capacity: 620mL (21.0oz)
- Sachet Ratio: 1:1
- Mechanical Advantage Ratio: 18:1
- Viscosity: Low / Medium
- Standard Color: Black / Blue
- Customized Versions: Yes

Dimensions

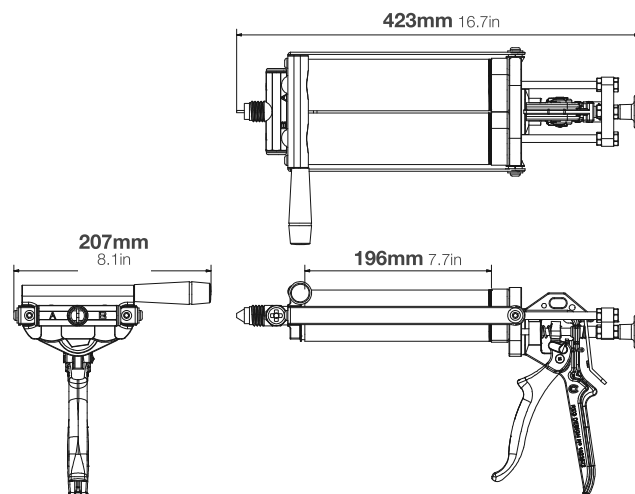

Part number:

DM2C 620-01-r18-001

Article number:

177651

Packaging:

1 per box

Matching MIXPAC™ cartridges

Compatible sachet

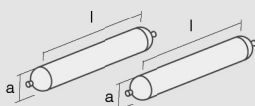

2x 310ml Sachet
620mL / 1:1 PP

| 1:1 | mm | inch |
|-----|-------|-------|
| l | 215.0 | 8.46 |
| a | Ø79.0 | Ø3.11 |
| c | 160.0 | 6.3 |

Conversion kits

Matching accessories

Connecting manifold supplied for 2x200mL cartridges on page 145.



CBM 310S

620mL Sachet Dispenser

Epoxy coated steel frame
for efficient dispensing



Epoxy coated aluminum handle
ergonomically design for comfort

Model shown: CBM 310S 620mL

Features

- High quality cast aluminum handle
- Epoxy coated steel frame support
- Sintered alloy catch plate
- Minimum trigger pressure
- Customization possible

Benefits

- For day long comfortable use
- For efficient dispensing
- Wear compensation device (WCD)
- For effortless use
- Customer labelling

Applications



Bonding



Sealing



Shimming

Product by range

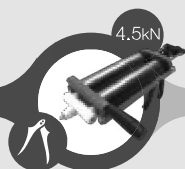

CBM 310/S



CBM 310/XC



CBM 310/CP(X)

The **PPM 1500X** 2-component manual dispenser a high-powered 25:1 mechanism with epoxy coated steel frame offers efficient effortless dispensing.

Specifications

- Lightweight: 1.7kg / 3.7lbs
- Frame Length: 241mm / 9.5inch
- Maximum Thrust: 4.5kN
- Handle Material: Epoxy Coated Aluminum
- Frame Material: Epoxy Coated Steel
- Tool Component Approvals: REACH
- Cartridge Capacity: 1500mL (52.8oz)
- Cartridge Ratio: 1:1
- Mechanical Advantage Ratio: 25:1
- Viscosity: High
- Standard Color: Black / Blue
- Customized Versions: Yes

Dimensions

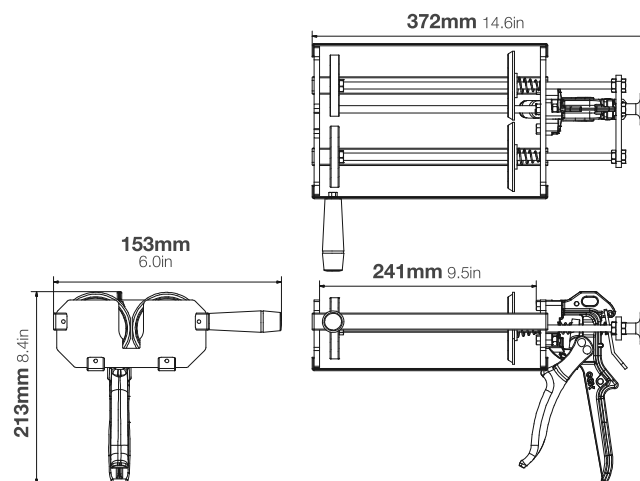

Part number:

DM2C 1500-01-r25-001

Article number:

159304 / M750X/1 (US) 1500mL (1:1)

Packaging:

1 per Box

Matching MIXPAC™ side-by-side cartridges



J-System Cartridge
1500mL / 1:1 PP / PP-GF

Compatible side-by-side cartridges

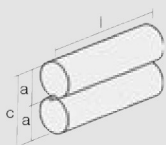

Plastic Cartridge
1500mL / 1:1 PP

| 1:1 | mm | inch |
|-----|-------|-------|
| l | 215.0 | 8.46 |
| a | Ø79.0 | Ø3.11 |
| c | 160.0 | 6.3 |

Conversion kits

Matching accessories



PPM 1500X

1500mL Cartridge Dispenser

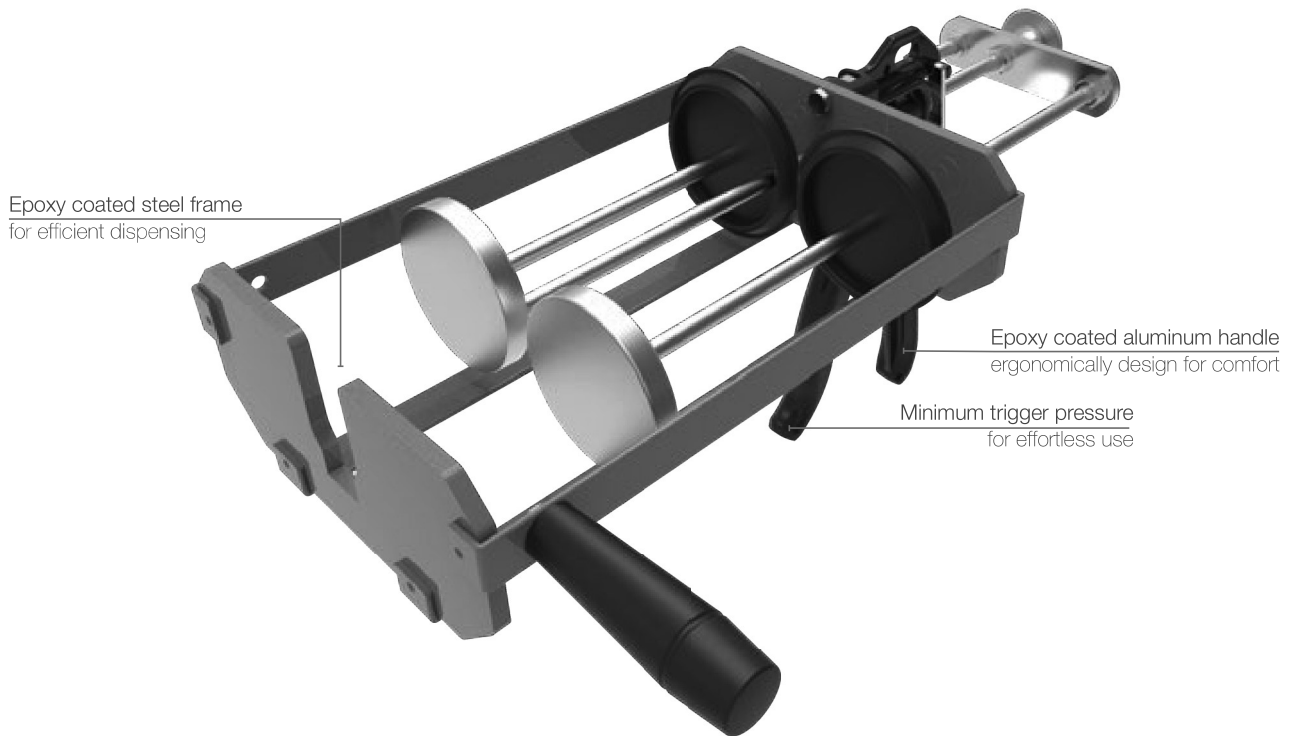

Model shown: PPM 1500X 1500mL

Features

- High quality cast aluminum handle
- Epoxy coated steel frame support
- Sintered alloy catch plate
- Customization possible

Benefits

- For day long comfortable use
- For efficient dispensing
- Wear compensation device (WCD)
- Customer labelling

Applications



Product by range

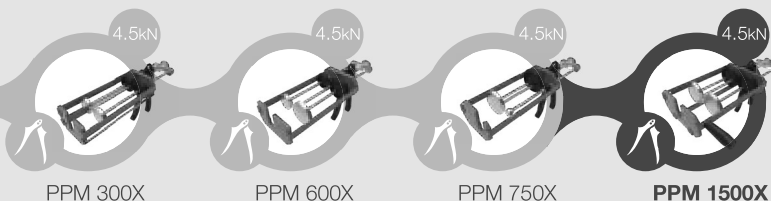

The **PPM 750X** 2-component manual dispenser has a high-powered 25:1 mechanism with epoxy coated steel frame offering efficient effortless dispensing.

Specifications

- Lightweight: 1.7kg / 3.7lbs
- Frame Length: 234mm / 9.2inch
- Maximum Thrust: 4.5kN
- Handle Material: Epoxy Coated Aluminum
- Frame Material: Epoxy Coated Steel
- Tool Component Approvals: REACH
- Cartridge Capacity: 825mL (29.0oz)
- Cartridge Ratio: 10:1
- Mechanical Advantage Ratio: 25:1
- Viscosity: High
- Standard Color: Black / Blue
- Customized Versions: Yes

Dimensions

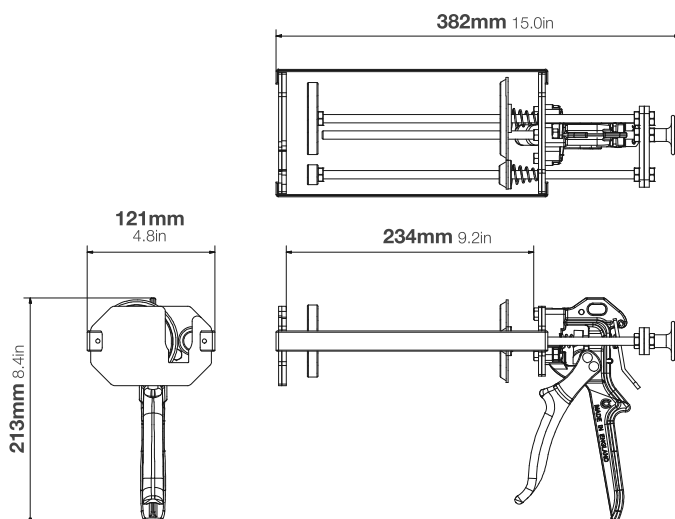

Part number:

DM2C 1500-10-r25-001

Article number:

159305 / M750X/10 (US) 825mL (10:1)

Packaging:

1 per Box

Matching MIXPAC™ side-by-side cartridges



J-System Cartridge
825mL / 10:1 PP/PA

Compatible side-by-side cartridges

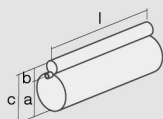

Plastic Cartridge
825mL / 10:1 PP

| 10:1 | mm | inch |
|------|-------|-------|
| l | 216.0 | 8.5 |
| a | Ø80.7 | Ø3.18 |
| b | Ø28.6 | Ø1.13 |
| c | 109.0 | 4.29 |

Conversion kits

Matching accessories



PPM 750X

825mL Cartridge Dispenser



Model shown: PPM 750X 825mL

Features

- High quality cast aluminum handle
- Epoxy coated steel frame support
- Sintered alloy catch plate
- Customization possible

Benefits

- For day long comfortable use
- For efficient dispensing
- Wear compensation device (WCD)
- Customer labelling

Applications



Product by range

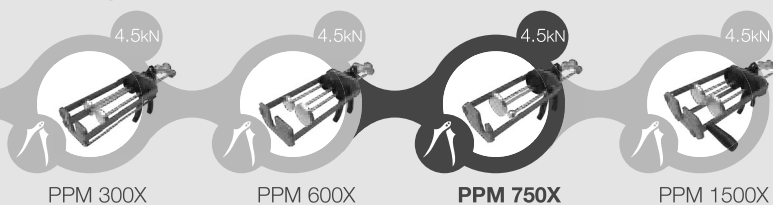

The **PPM 600X** 2-component manual dispenser has a high-powered 25:1 mechanism while the wear compensation device gives the dispenser a longer life.

Specifications

- Lightweight: 2.1kg / 4.8lbs
- Frame Length: 230mm / 9.1in
- Maximum Thrust: 4.5kN
- Handle Material: Epoxy Coated Aluminum
- Frame Material: Epoxy Coated Steel
- Tool Component Approvals: REACH
- Cartridge Capacity: 750mL (26oz), 900mL (31.6oz), 1200mL (42oz)
- Cartridge Ratio: 1:1, 2:1, 4:1
- Mechanical Advantage Ratio: 25:1
- Viscosity: High
- Standard Color: Black / Blue
- Customized Versions: Yes

Dimensions

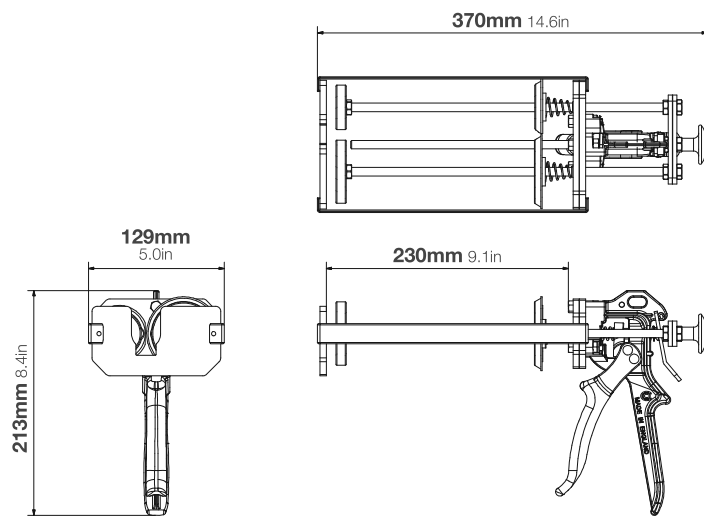

Part number:

DM2C 1200-01-r25-001
DM2C 1200-02-r25-001
DM2C 1200-04-r25-001

Article number:

177835 / M600X/1 (US) 1200mL (1:1)
177830 / M600X/2 (US) 900mL (2:1)
177832 / M600X/4 (US) 750mL (4:1)

Packaging:

1 per Box
1 per Box
1 per Box

Matching MIXPAC™ cartridges

Compatible side-by-side cartridges

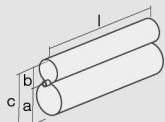

Plastic Cartridge
900mL / 2:1 PP/PA

| 2:1 | mm | inch |
|-----|-------|-------|
| l | 225.0 | 8.86 |
| a | Ø69.0 | Ø2.72 |
| b | Ø50.0 | Ø1.97 |
| c | 119.0 | 4.69 |

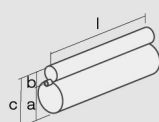

Plastic Cartridge
750mL / 4:1 PP/PA

| 4:1 | mm | inch |
|-----|-------|-------|
| l | 217.0 | 8.54 |
| a | Ø68.0 | Ø2.68 |
| b | Ø34.0 | Ø1.34 |
| c | 102.0 | 4.0 |

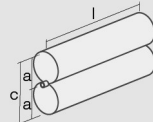

Plastic Cartridge
1200mL / 1:1 PP

| 1:1 | mm | inch |
|-----|-------|-------|
| l | 217.0 | 8.54 |
| a | Ø68.0 | Ø2.68 |
| c | 136.0 | 5.35 |

Conversion kits

Matching accessories



PPM 600X

750/900/1200mL Cartridge Dispenser

Epoxy coated steel frame supports cartridge

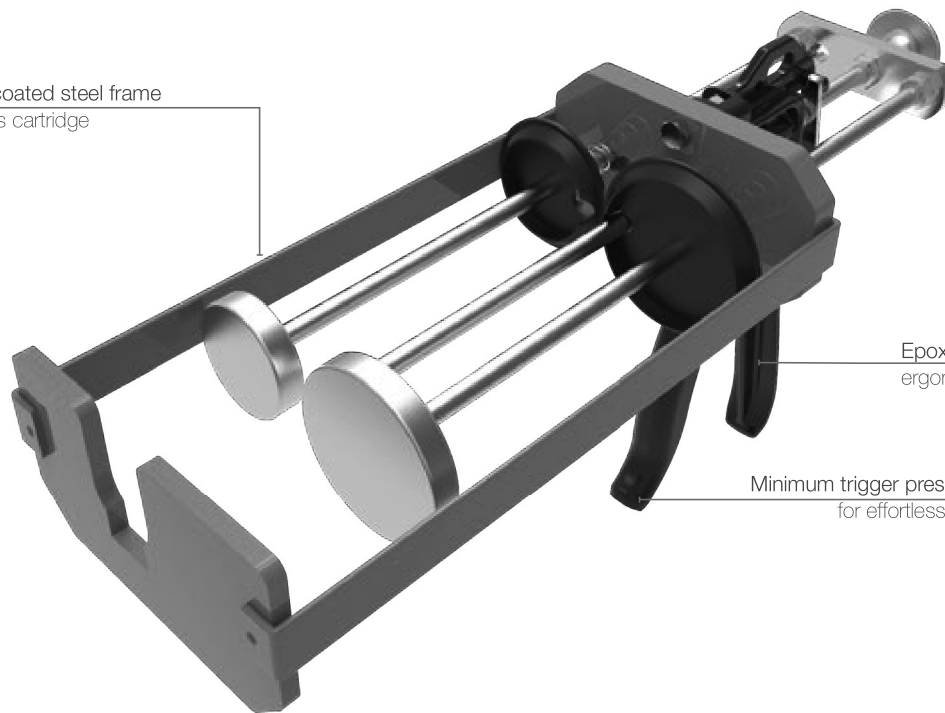

Epoxy coated aluminum handle ergonomically design for comfort

Minimum trigger pressure for effortless use

Model shown: PPM 600X 900mL

Features

- High quality cast aluminum handle
- Epoxy coated steel frame support
- Sintered alloy catch plate
- Customization possible

Benefits

- For day long comfortable use
- For efficient dispensing
- Wear compensation device (WCD)
- Customization possible

Applications



Product by range

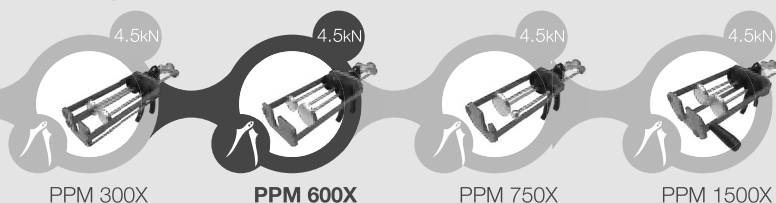

The **PPM 300X** 2-component manual dispenser has a high-powered 25:1 mechanism designed for use with high viscosity sealants and adhesives.

Specifications

- Lightweight: 1.7kg / 3.7lbs
- Frame Length: 232mm / 9.1inch
- Maximum Thrust: 4.5kN
- Handle Material: Epoxy Coated Aluminum
- Frame Material: Epoxy Coated Steel
- Tool Component Approvals: REACH
- Cartridge Capacity: 375mL (12.7oz), 450mL (15.3oz), 600mL (20.3oz)
- Cartridge Ratio: 1:1, 2:1, 4:1
- Mechanical Advantage Ratio: 25:1
- Viscosity: High
- Standard Color: Black / Blue
- Customized Versions: Yes

Dimensions

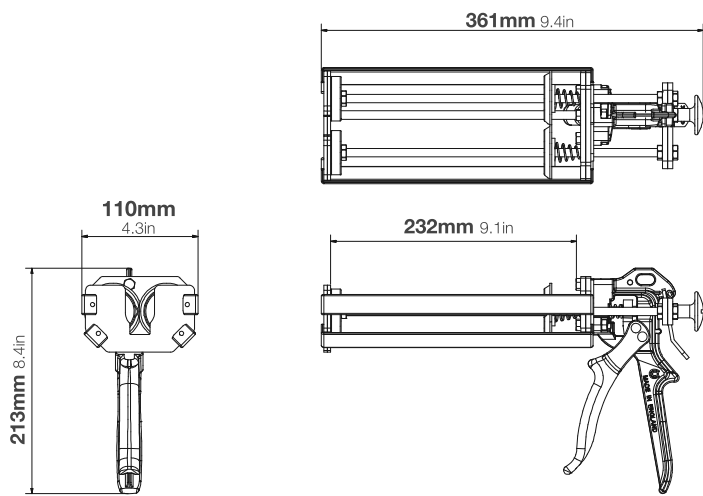

Part number:

DM2C 600-MR-r25-001

Article number:

167327 (multi ratio)

Packaging:

10 per Box

Matching MIXPAC™ cartridges

Compatible side-by-side cartridges

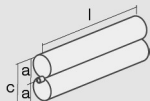

Plastic Cartridge
600mL / 1:1 PP

| 1:1 | mm | inch |
|-----|-------|-------|
| l | 217.0 | 8.54 |
| a | Ø48.0 | Ø1.89 |
| c | 95.5 | 3.76 |

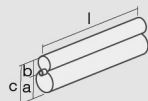

Plastic Cartridge
450mL / 2:1 PP/PA

| 2:1 | mm | inch |
|-----|-------|-------|
| l | 215.0 | 8.46 |
| a | Ø49.5 | Ø1.95 |
| b | Ø36.2 | Ø1.43 |
| c | 86.0 | 3.39 |

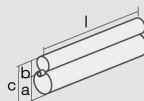

Plastic Cartridge
375mL / 4:1 PP

| 4:1 | mm | inch |
|-----|-------|-------|
| l | 215.0 | 8.46 |
| a | Ø49.3 | Ø1.94 |
| b | Ø26.7 | Ø1.05 |
| c | 76.0 | 2.99 |

Conversion kits

Matching accessories



PPM 300X

375/450/600mL Cartridge Dispenser

Epoxy coated steel frame
for efficient dispensing



Epoxy coated aluminum handle
ergonomically design for comfort

Minimum trigger pressure
for effortless use

Model shown: PPM 300X 600mL

Features

- High quality cast aluminum handle
- Epoxy coated steel frame support
- Sintered alloy catch plate
- Customization possible

Benefits

- For day long comfortable use
- For efficient dispensing
- Wear compensation device (WCD)
- Customer labelling

Applications



Product by range

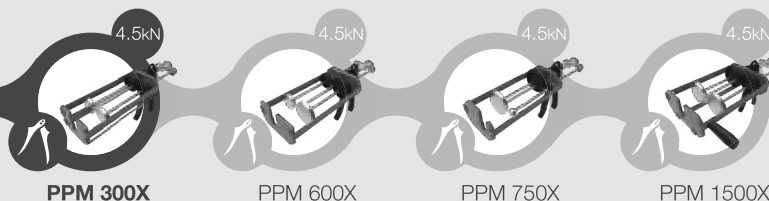

The **PPM 300 LV MR** 2-component manual dispenser offers efficient dispensing while the wear compensation device gives the dispenser a longer life.

Specifications

- Lightweight: 1.7kg / 3.7lbs
- Frame Length: 240mm / 9.4in
- Maximum Thrust: 2.5kN
- Handle Material: Epoxy Coated Aluminum
- Frame Material: Epoxy Coated Steel
- Tool Component Approvals: REACH
- Cartridge Capacity: 450mL (15.8oz)
- Cartridge Ratio: 1:1, 2:1
- Mechanical Advantage Ratio: 12:1
- Viscosity: Low / Medium
- Standard Color: Black / Blue
- Customized versions: Yes

Dimensions

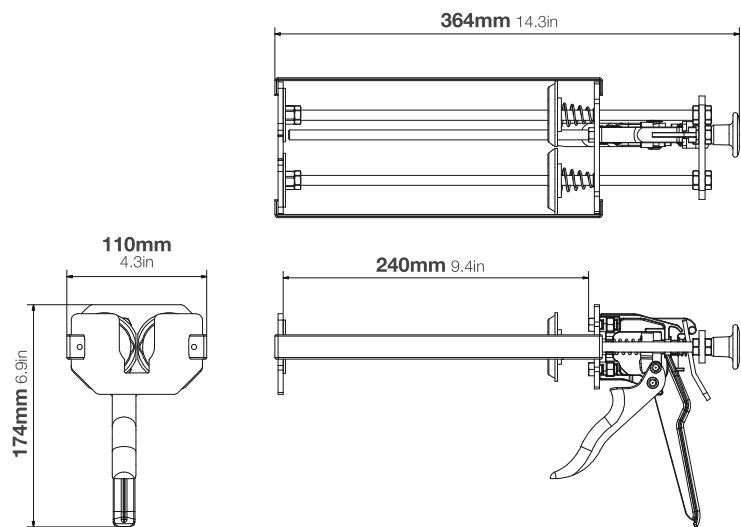

Part number:

M300 LV/2 (US)
M300 LV (US)

Article number:

-
-

Packaging:

1 per Box
1 per Box

Matching MIXPAC™ cartridges

Compatible side-by-side cartridges

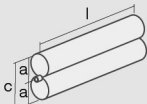

Plastic Cartridge
600mL / 1:1 PP

| 1:1 | mm | inch |
|-----|-------|-------|
| l | 217.0 | 8.54 |
| a | Ø48.0 | Ø1.89 |
| c | 95.5 | 3.76 |

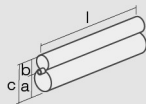

Plastic Cartridge
450mL / 2:1 PP/PA

| 2:1 | mm | inch |
|-----|-------|-------|
| l | 215.0 | 8.46 |
| a | Ø46.5 | Ø1.83 |
| b | Ø33.2 | Ø1.31 |
| c | 86.0 | 3.39 |

Conversion kits

Matching accessories



PPM 300 LV MR

450/600mL Cartridge Dispenser

Epoxy coated steel frame
for efficient dispensing

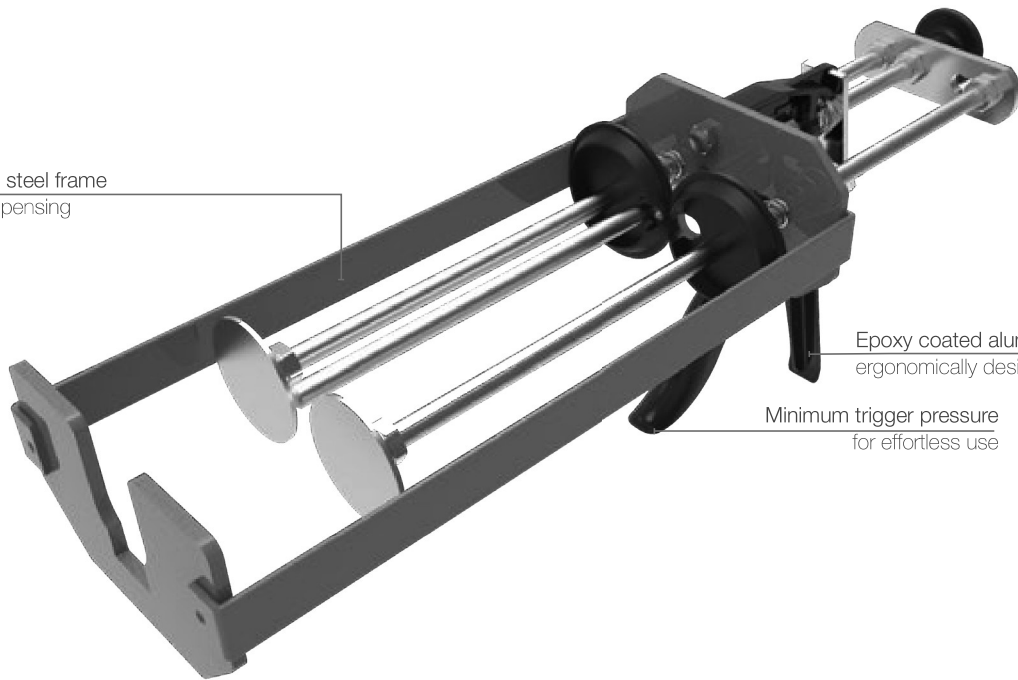

Epoxy coated aluminum handle
ergonomically design for comfort

Minimum trigger pressure
for effortless use

Model shown: PPM 300 LV MR 600mL

Features

- High quality cast aluminum handle
- Epoxy coated steel frame support
- Sintered alloy catch plate
- Customization possible

Benefits

- For day long comfortable use
- For efficient dispensing
- Wear compensation Device (WCD)
- Customer labelling

Applications



Bonding



Crack
Repair



Sealing



Water
Proofing



Solid
Surface

Product by range



PPM 75

PPM 150

PPM 300 LV MR

The **PPM 150** 2-component manual dispenser with 18:1 high-powered mechanism and snap fit cartridge straps for optimal cartridge support and fit.

Specifications

- Lightweight: 1.52kg / 3.3lbs
- Frame Length: 236mm / 14.4inch
- Maximum Thrust: 3.5kN
- Handle Material: Epoxy Coated Aluminum
- Frame Material: Epoxy Coated Steel
- Tool Component Approvals: REACH
- Cartridge Capacity: 300mL (10.5oz)
- Cartridge Ratio: 1:1, 2:1
- Mechanical Advantage Ratio: 18:1
- Viscosity: Medium / High
- Standard Color: Black / Blue
- Customized Versions: Yes

Dimensions

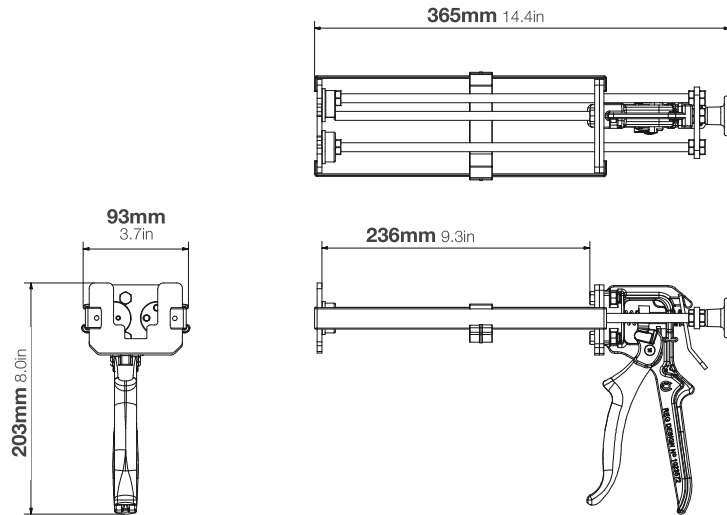

Part number:

DM2C 300-01-r18-001

Article number:

167326 / M150 (US)

Packaging:

1 per Box

Matching MIXPAC™ cartridges

Compatible side-by-side cartridges

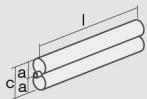

Plastic Cartridge
300mL / 1:1 PP

| 1:1 | mm | inch |
|-----|-------|-------|
| l | 217 | 8.54 |
| a | Ø36.1 | Ø1.42 |
| c | 78.20 | 3.08 |

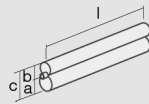

Plastic Cartridge
225mL / 2:1 PP

| 2:1 | mm | inch |
|-----|--------|-------|
| l | 217.0 | 8.54 |
| a | Ø34.0 | Ø1.34 |
| b | Ø24.05 | Ø0.95 |
| c | 58.05 | 2.29 |

Conversion kits

Matching accessories



PPM 150

300mL Cartridge Dispenser

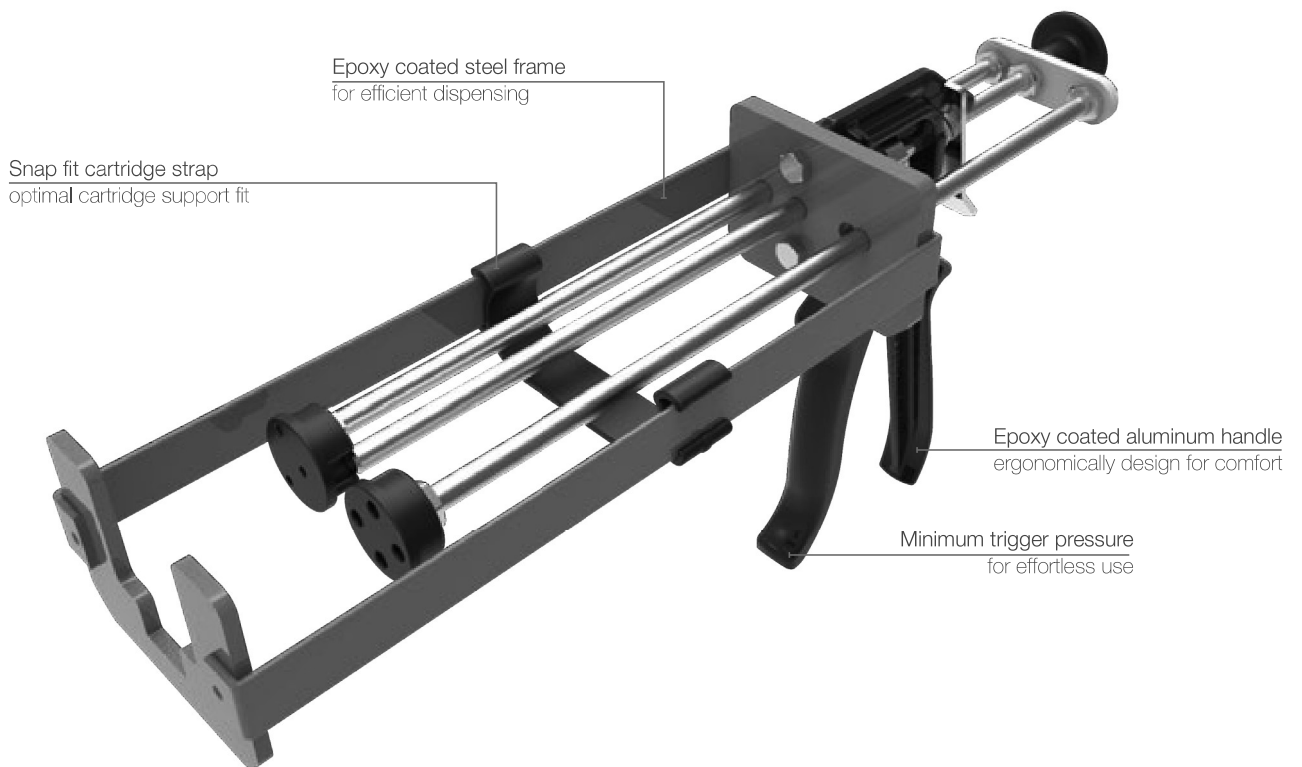

Model shown: PPM 150 300mL

Features

- High quality cast aluminum handle
- Epoxy coated steel frame support
- Sintered alloy catch plate
- Snap fit cartridge strap
- Customization possible

Benefits

- For day long comfortable use
- For efficient dispensing
- Wear compensation device (WCD)
- For optimal cartridge support
- Customer labelling

Applications



Bonding



Sealing



Shimming

Product by range

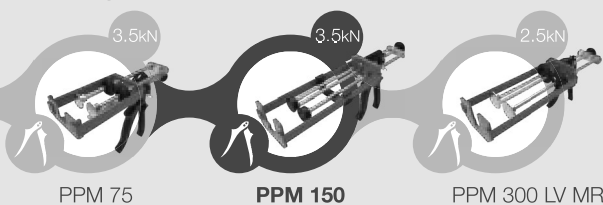

The **PPM 75** 2-component manual dispenser, designed with 18:1 high-powered mechanism for efficient dispensing. While the wear compensation device gives the dispenser a longer life.

Specifications

- Lightweight: 1.0kg / 2.2lbs
- Frame Length: 129mm / 5.1inch
- Maximum Thrust: 3.5kN
- Handle Material: Epoxy Coated Aluminum
- Frame Material: Epoxy Coated Steel
- Tool Component Approvals: REACH
- Cartridge Capacity: 150mL (5.3oz)
- Cartridge Ratio: 1:1
- Mechanical Advantage Ratio: 18:1
- Viscosity: Medium / High
- Standard Color: Black / Blue
- Customized Versions: Yes

Dimensions

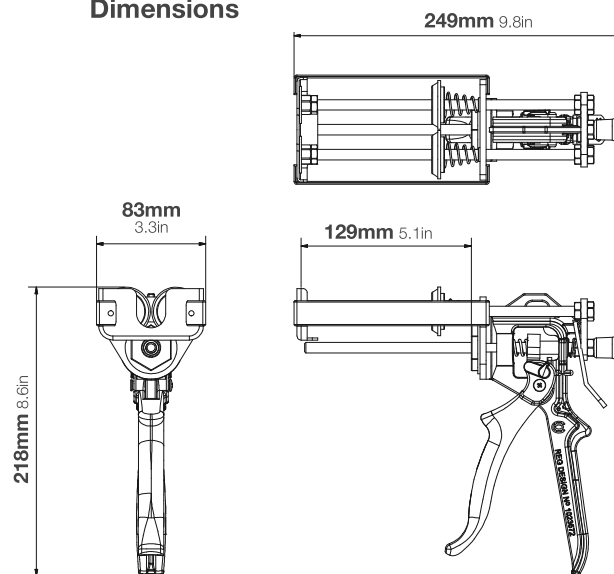

Part number:

DM2C 150-01-r18-001

Article number:

177794 / M75 (US)

Packaging:

10 per Box

Matching MIXPAC™ cartridges

Compatible side-by-side cartridges

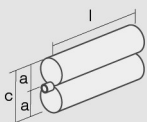

Plastic Cartridge
150mL / 1:1 PP

| 1:1 | mm | inch |
|-----|-------|-------|
| l | 115.0 | 4.53 |
| a | Ø37.0 | Ø1.46 |
| c | 75.0 | 2.9 |

Conversion kits

Matching accessories