

PARTS LIST			
ITEM	QTY	PART NUMBER	DESCRIPTION
3	1	LST580	1/2" LST SCREEN - 80 MESH
4	1	LSTM050B	MINI T-STRAINER BOWL
2	1	LSTM050G	MINI T-STRAINER GASKET
1	1	LSTM050H	1/2" NPT MINI T-STRAINER HEAD
5	1	CE050D	1/2" CE LABEL (N/S)
6	1	LST1200D	200 PSI DECAL (N/S)

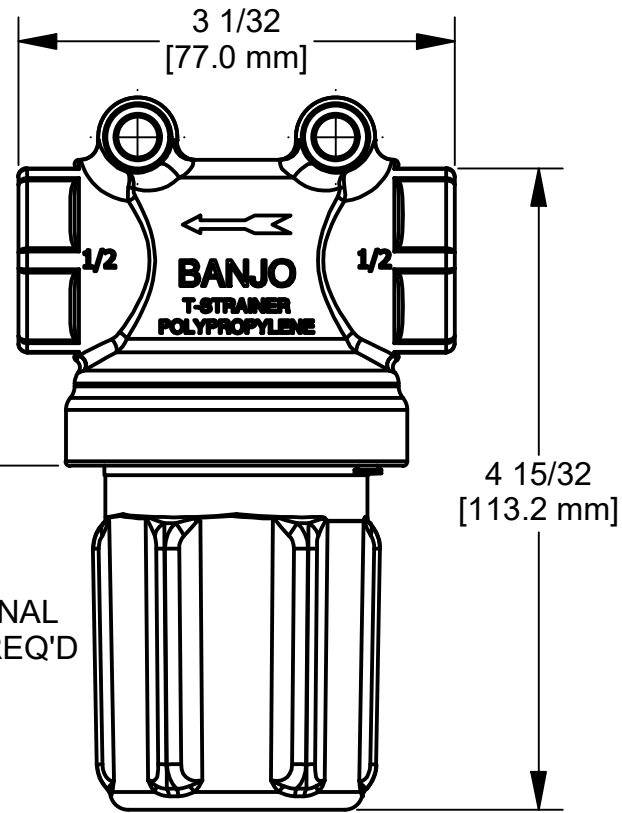

2 3/4" ADDITIONAL CLEARANCE REQ'D FOR SCREEN REMOVAL.

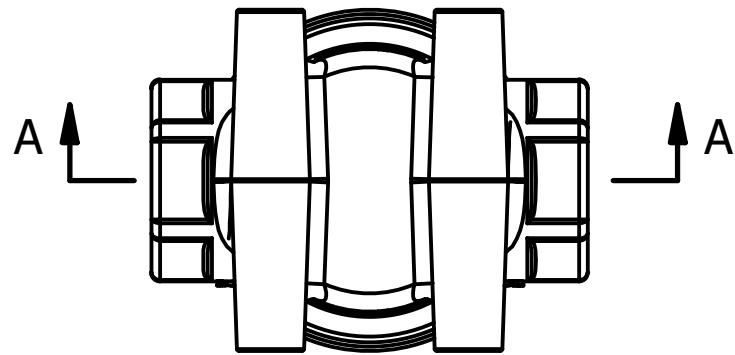
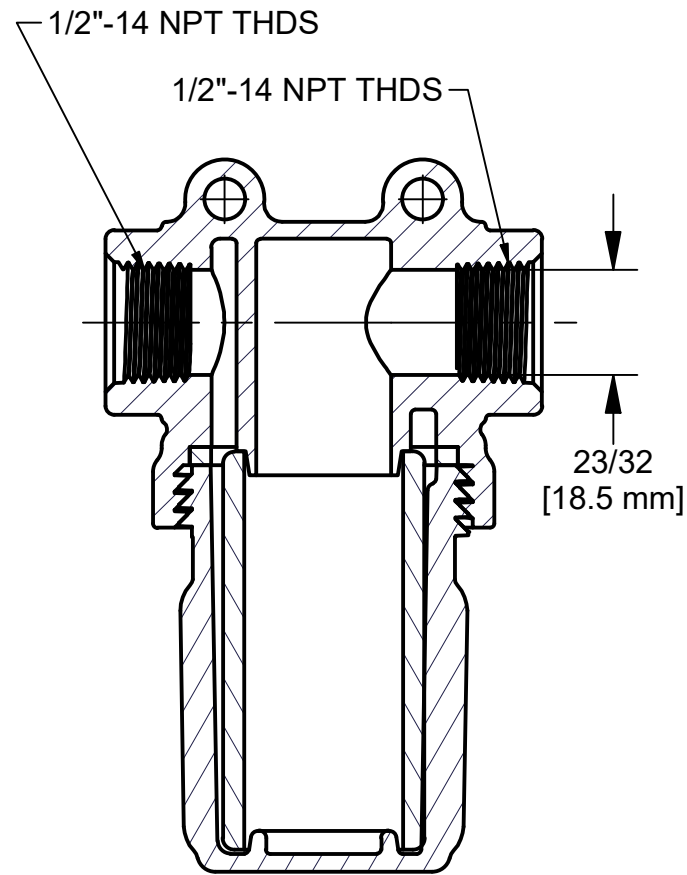

SECTION A-A  
SCALE 3 / 4

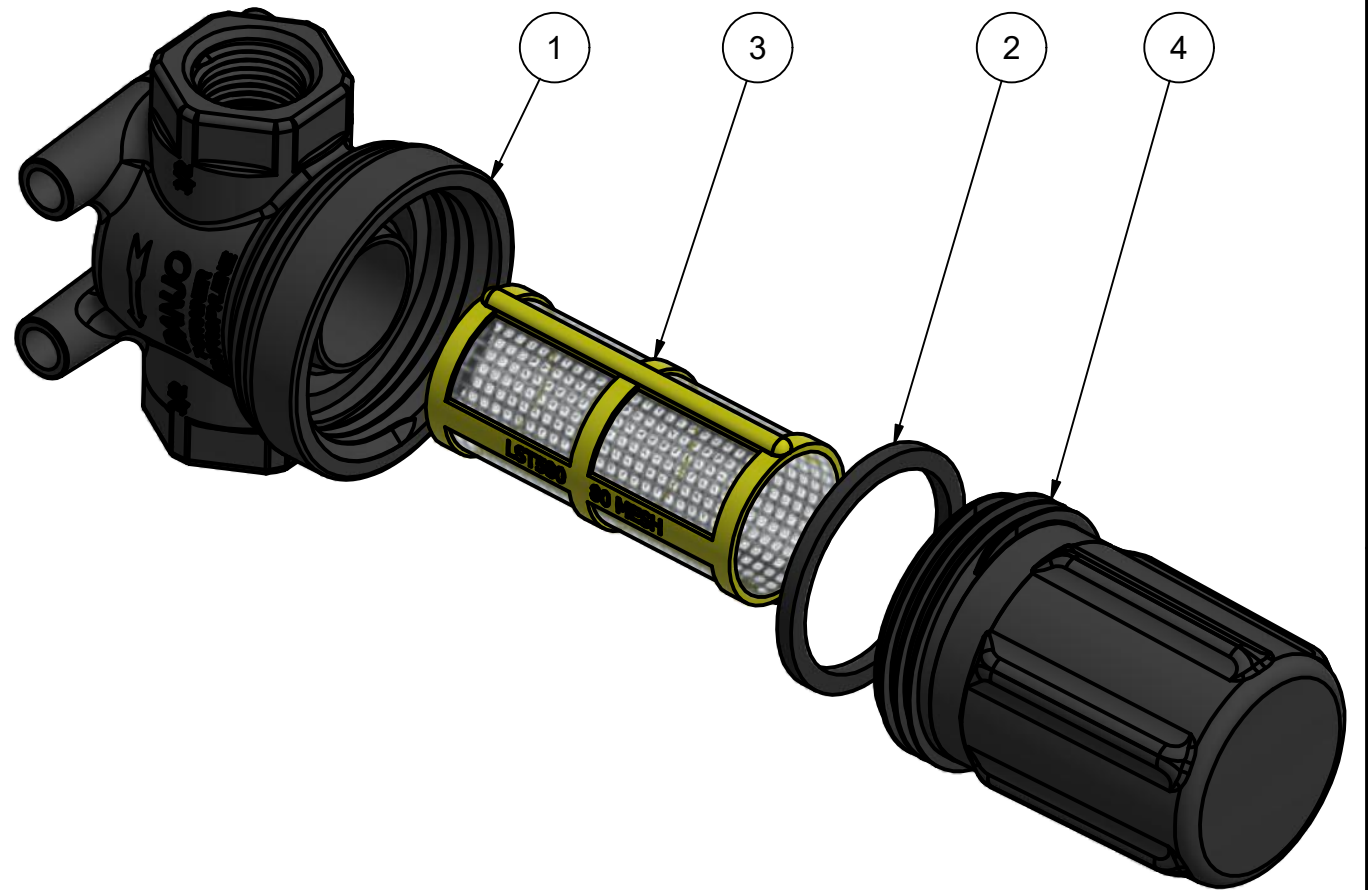

THIS DRAWING AND ALL INFORMATION CONTAINED THEREON ARE THE EXCLUSIVE PROPERTY OF BANJO CORPORATION.

UNLESS SPECIFICALLY NOTED, THIS DRAWING AND ITEMS SHOWN ON THIS DRAWING ARE SUBJECT TO CHANGE AT ANY TIME.



**BANJO CORPORATION**  
150 BANJO DRIVE, CRAWFORDSVILLE, IN 47933  
WEB SITE: WWW.BANJOCORP.COM  
E-MAIL: BANJOSALES@IDEXCORP.COM

DESCRIPTION  
1/2" T-STRAINER - 80 MESH

PART NUMBER  
LSTM050-80