

8 7 6 5 4 3 2 1

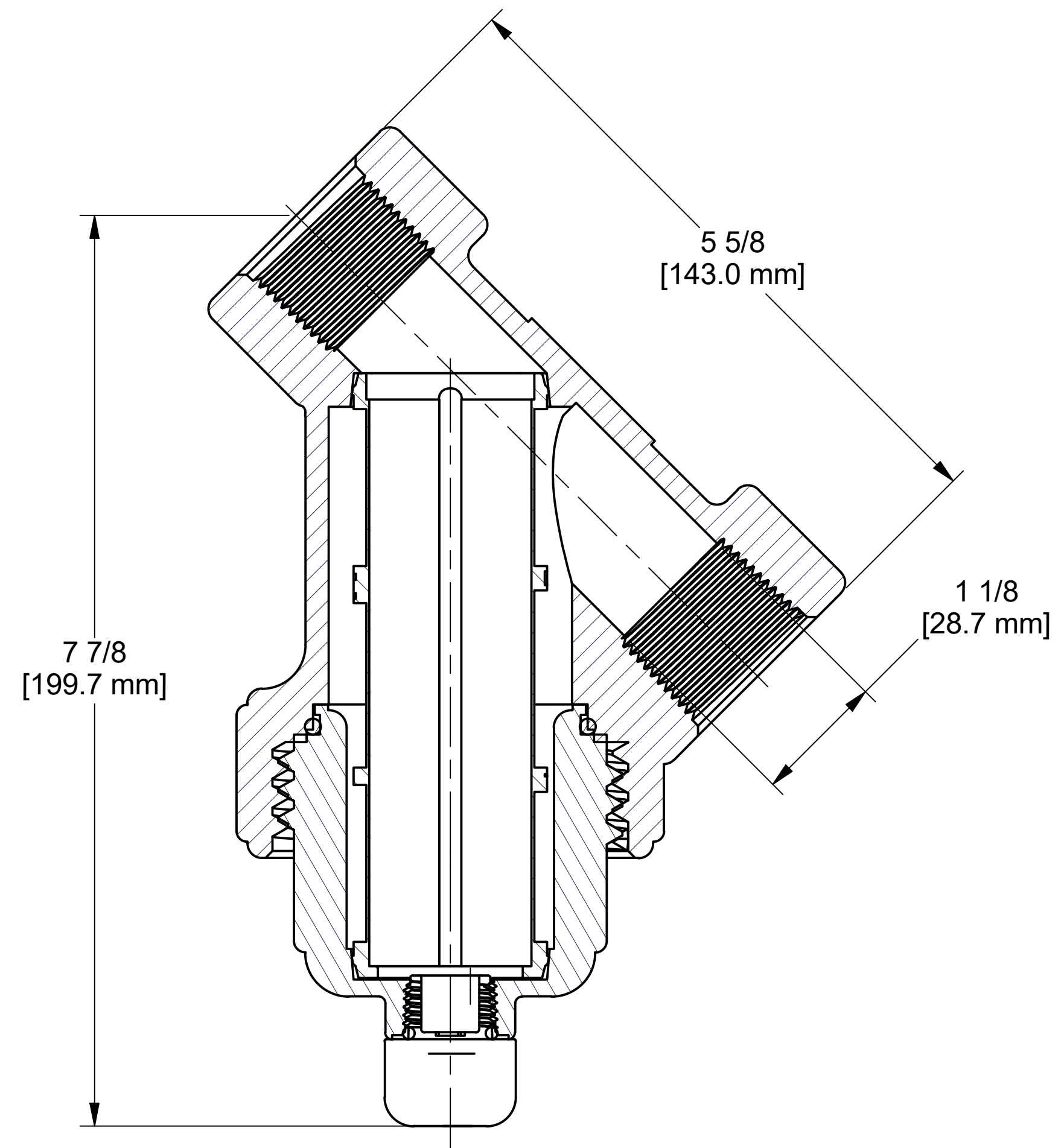

SECTION B-B  
SCALE 1 : 1

\*NOTE:  
ADDITIONAL CLEARANCE REQ'D  
FOR SCREEN REMOVAL: 5 1/4"

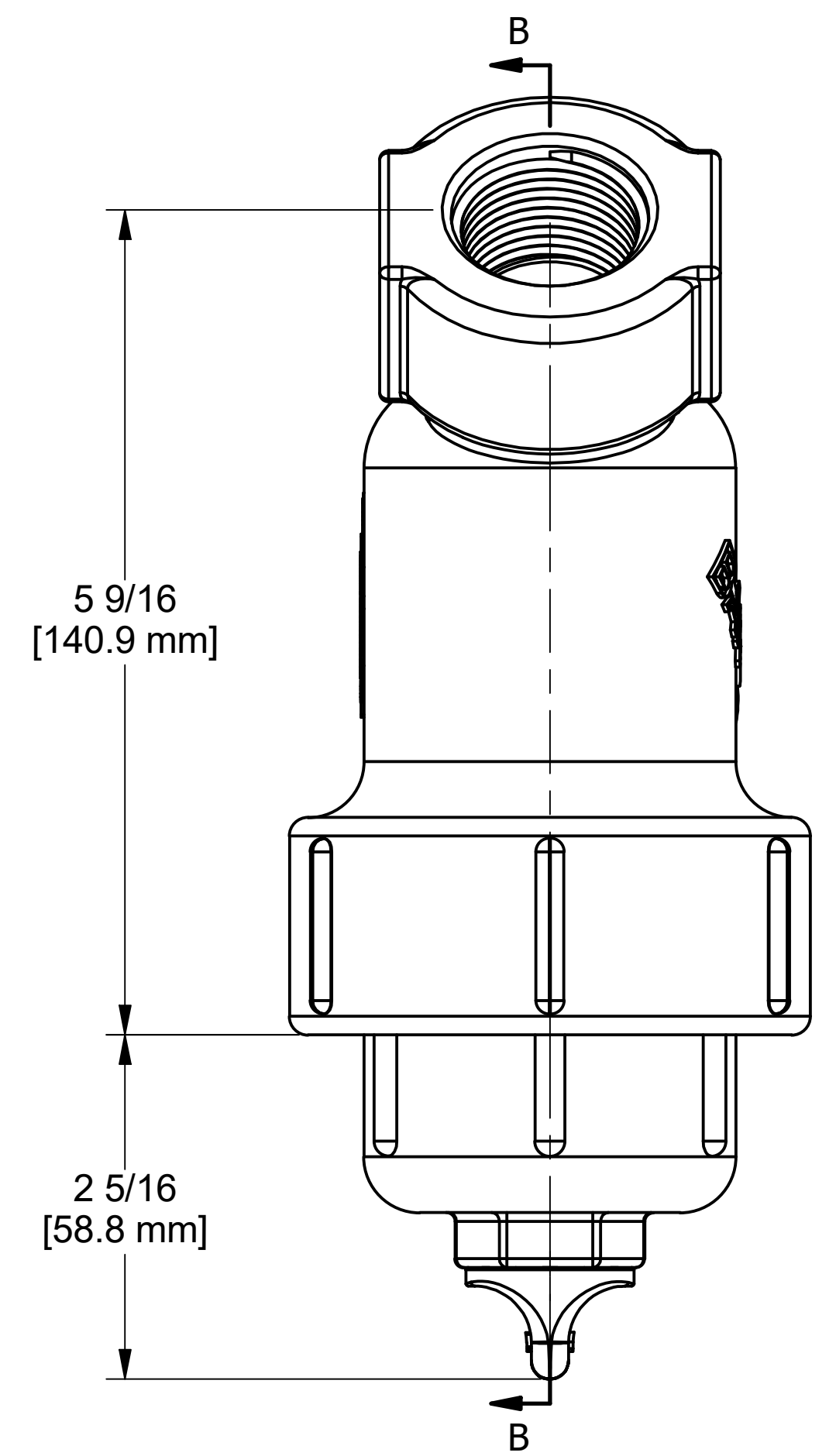
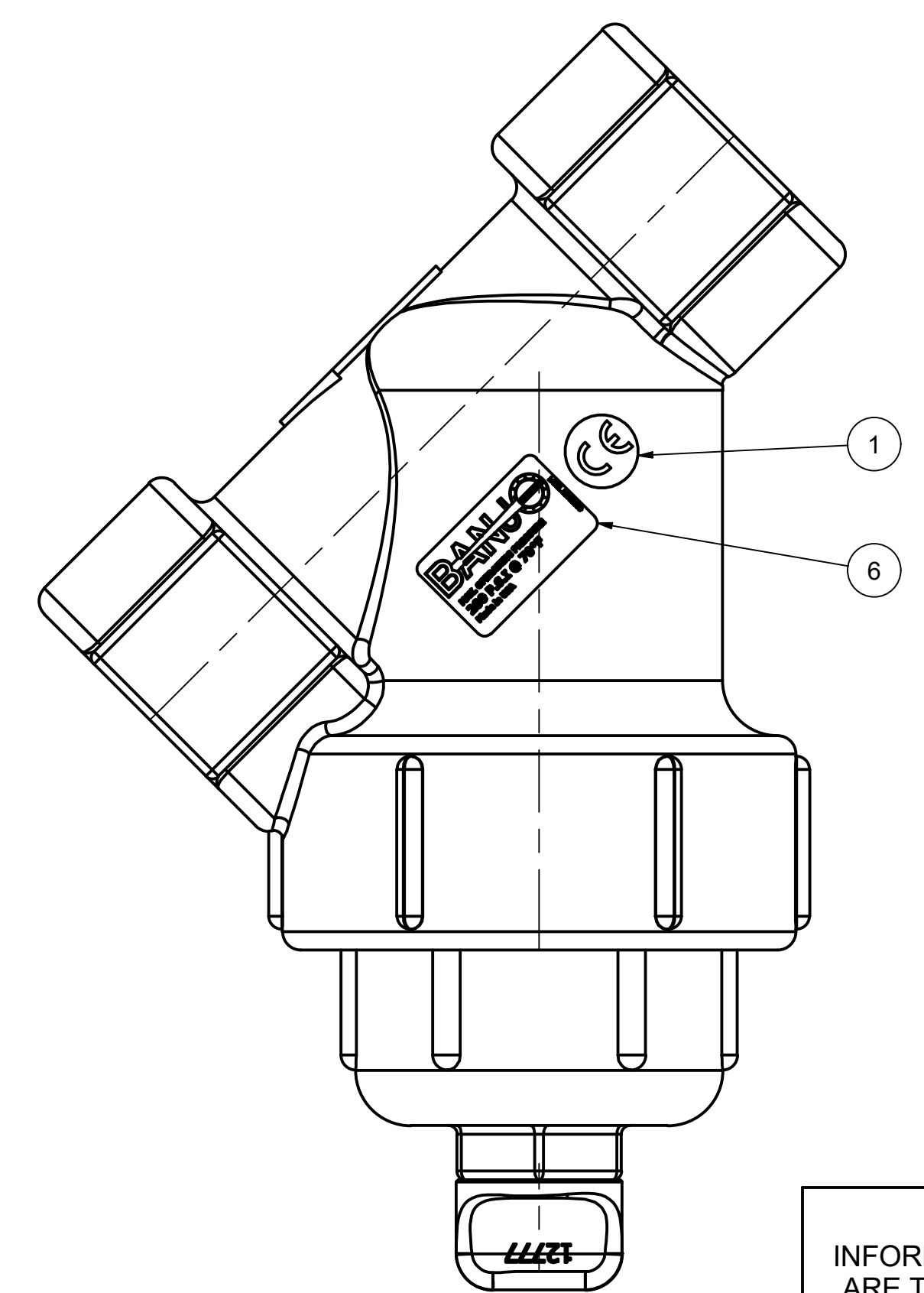
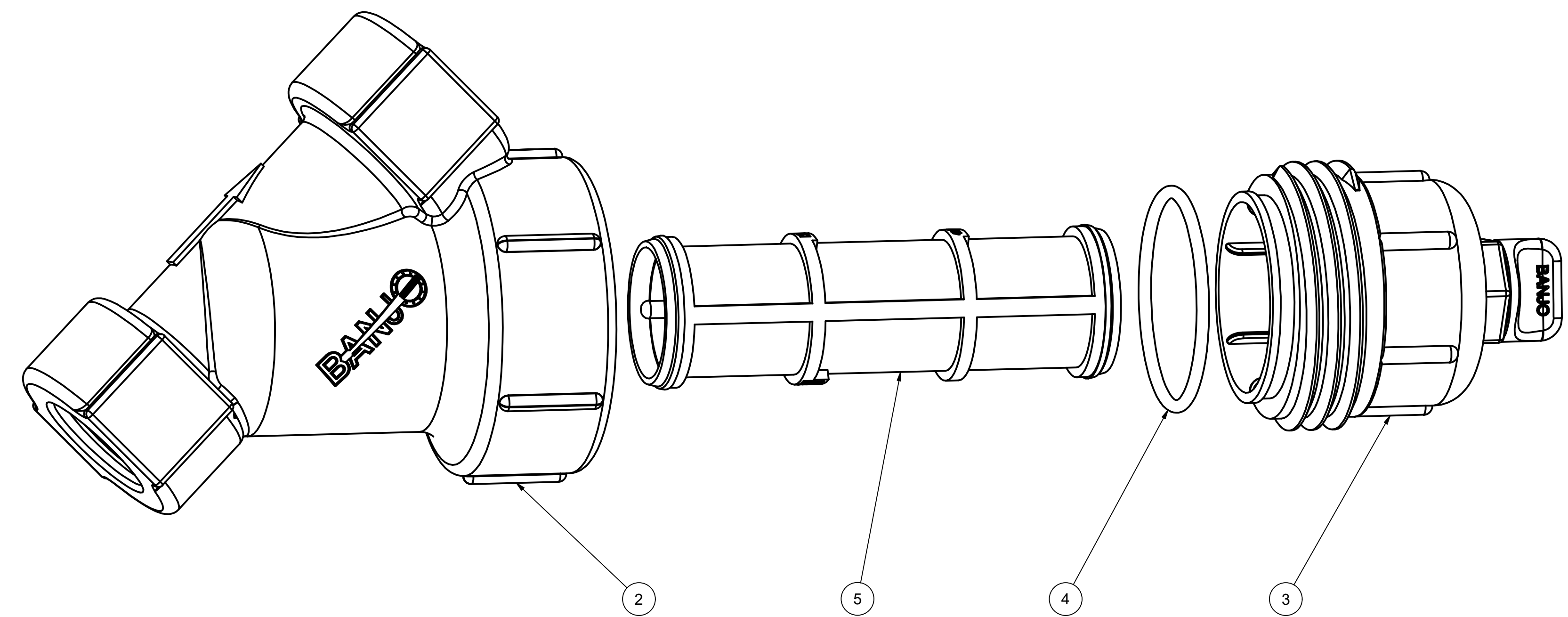
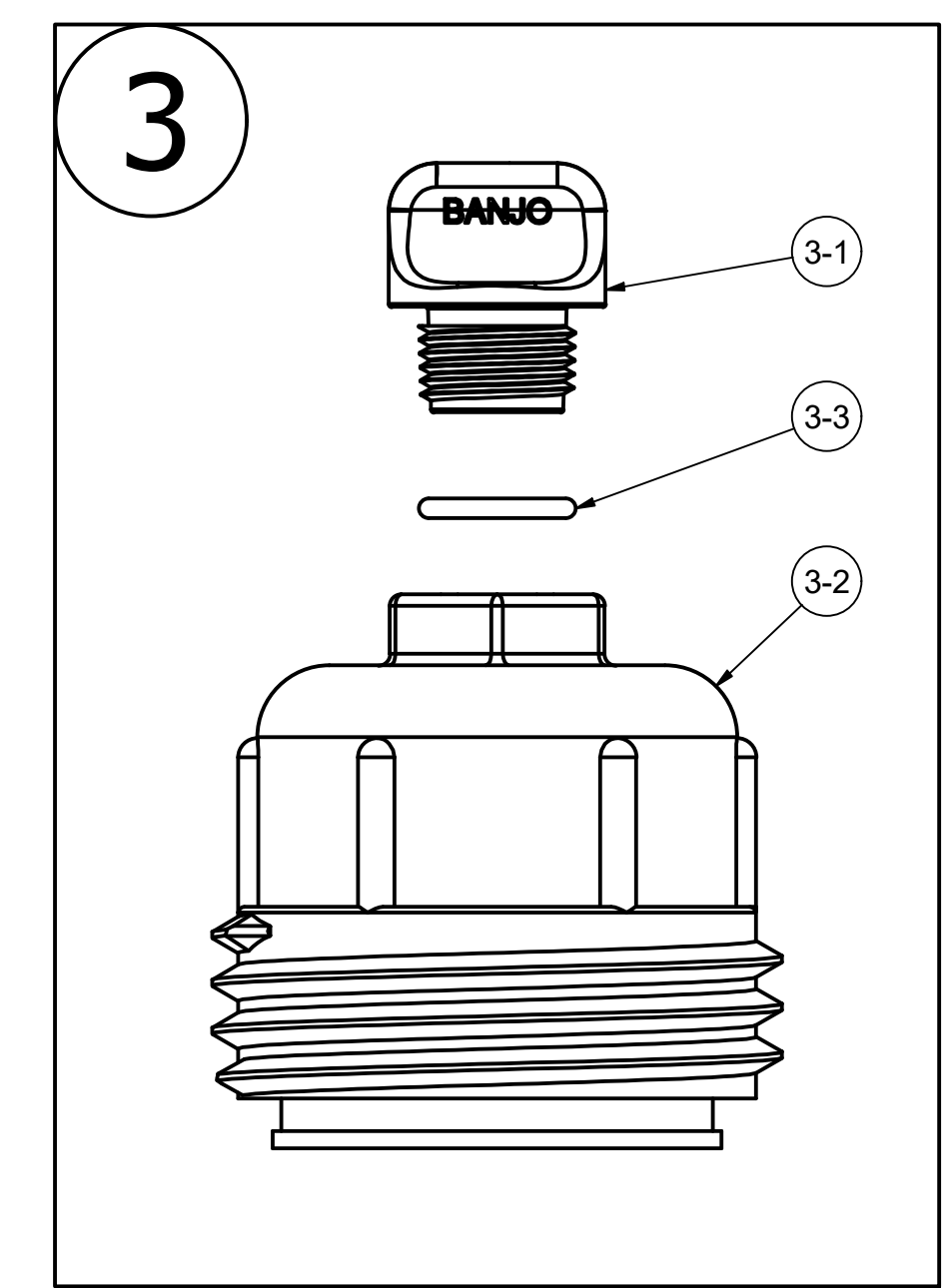

PARTS LIST			
ITEM	QTY	PART NUMBER	DESCRIPTION
1	1	CE050D	CE DECAL
2	1	LS100-B	1" LINE STRAINER BODY
3	1	LS100-C1	LINE STRAINER CAP ASSY
3-1	1	12777	1/2" DRAIN PLUG
3-2	1	LS100XC1	1" LINE STRAINER CAP
3-3	1	UV15163	AS568A -114 O-RING, EPDM, BROWN
4	1	LS100-G	AS568A -228 O-RING, EPDM, BLACK
5	1	LS140	1" LS SCREEN - 40 MESH
6	1	LST1200D	200 PSI DECAL

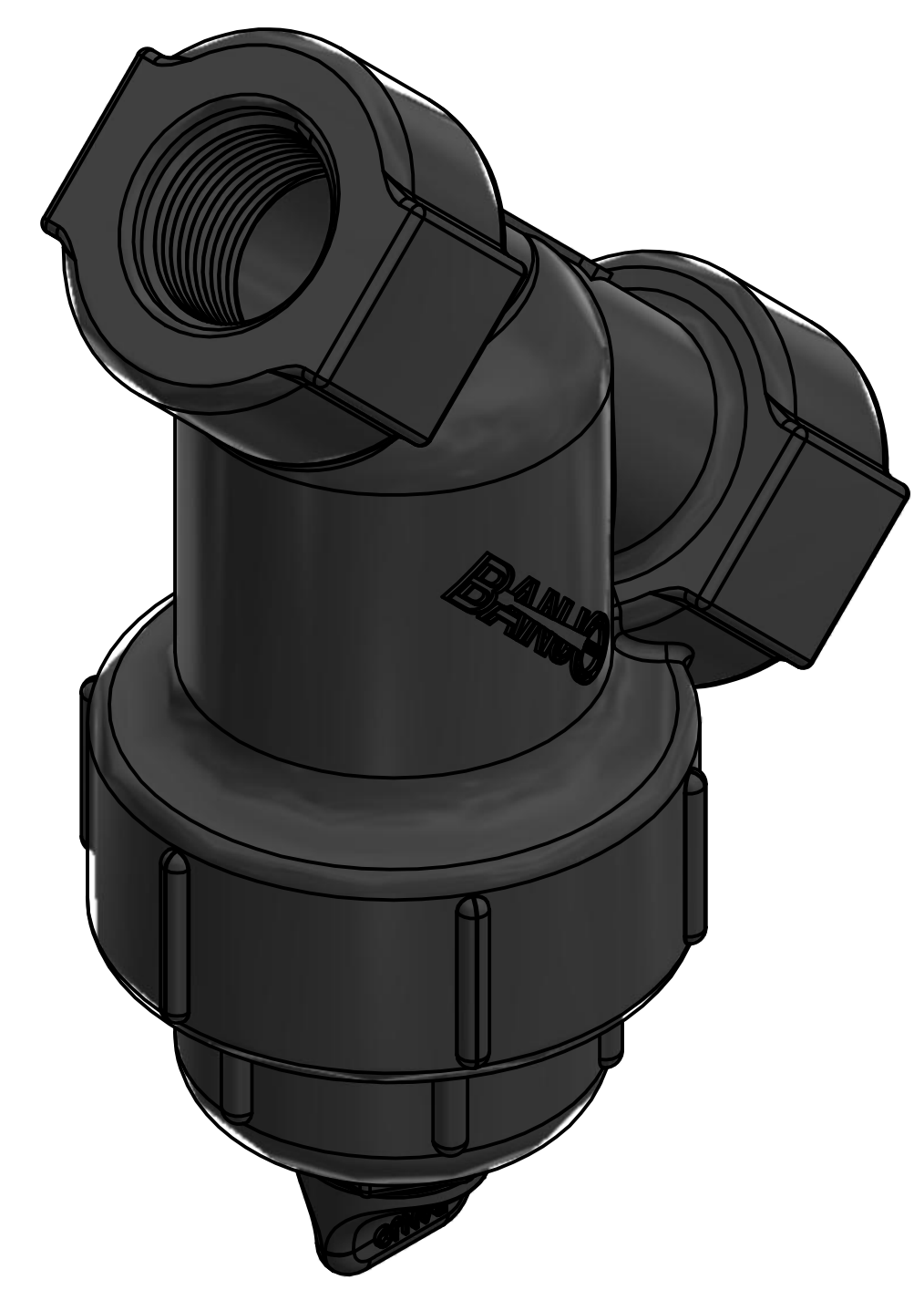

THIS DRAWING AND ALL INFORMATION CONTAINED THEREON ARE THE EXCLUSIVE PROPERTY OF BANJO CORPORATION.  
UNLESS SPECIFICALLY NOTED, THIS DRAWING AND ITEMS SHOWN ON THIS DRAWING ARE SUBJECT TO CHANGE AT ANY TIME.



BANJO CORPORATION  
150 BANJO DRIVE, CRAWFORDSVILLE, IN 47933  
WEB SITE: WWW.BANJO.CORP.COM  
E-MAIL: BANJOSALES@DEXCORP.COM

DESCRIPTION  
**1" LINE STRAINER 40 MESH**

PART NUMBER  
**LS100-40**

8 7 6 5 4 3 2 1