

*NOTE:
ADDITIONAL CLEARANCE REQ'D
FOR SCREEN REMOVAL: 5 1/4"

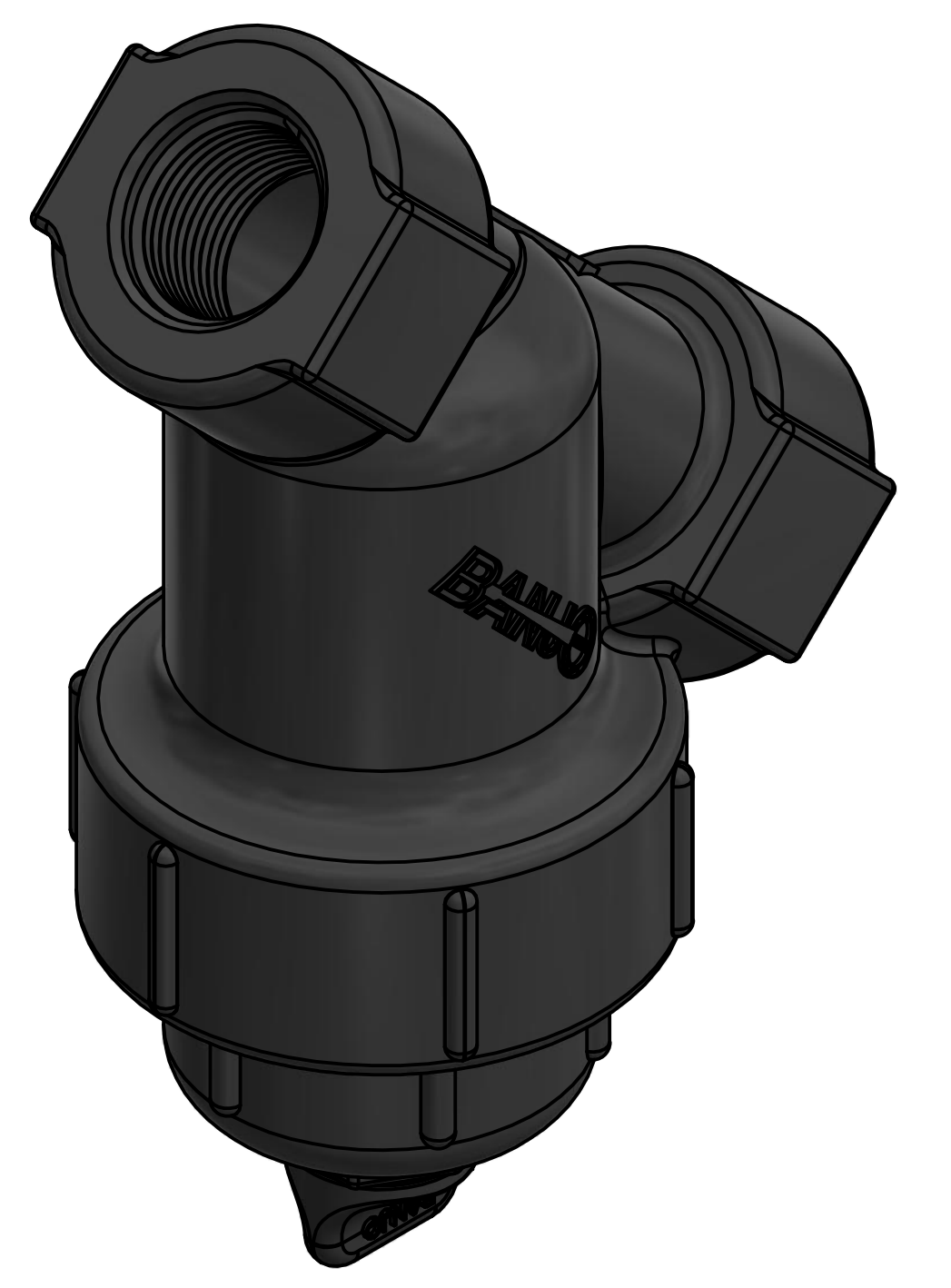
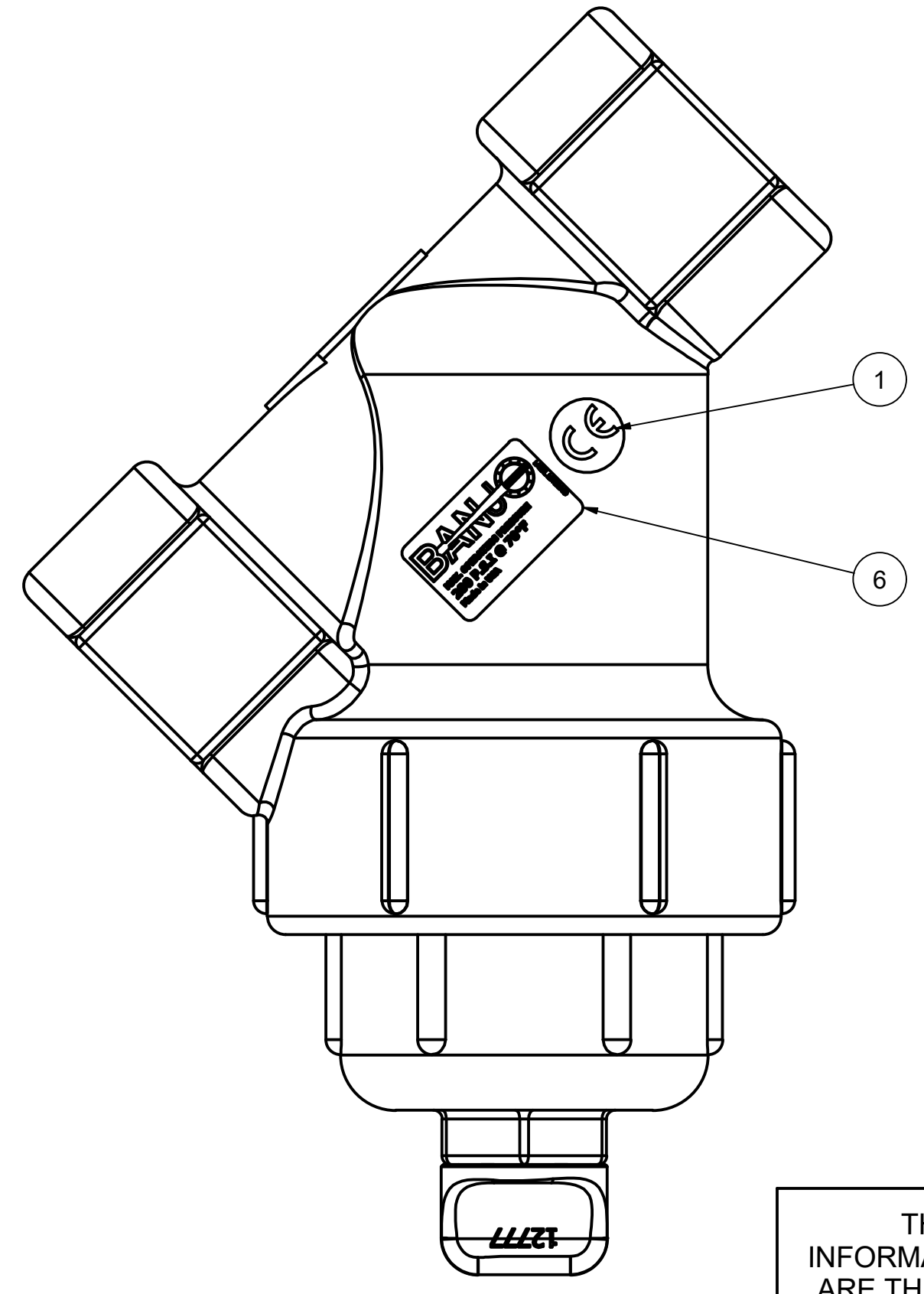
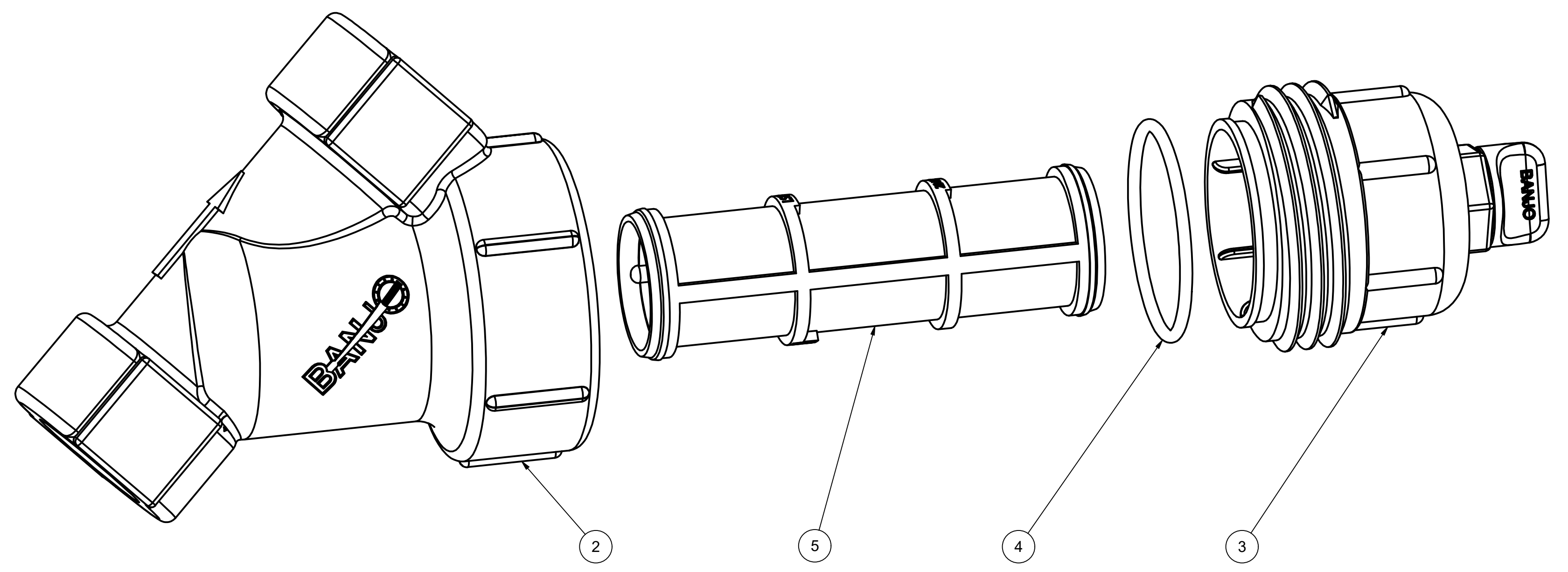
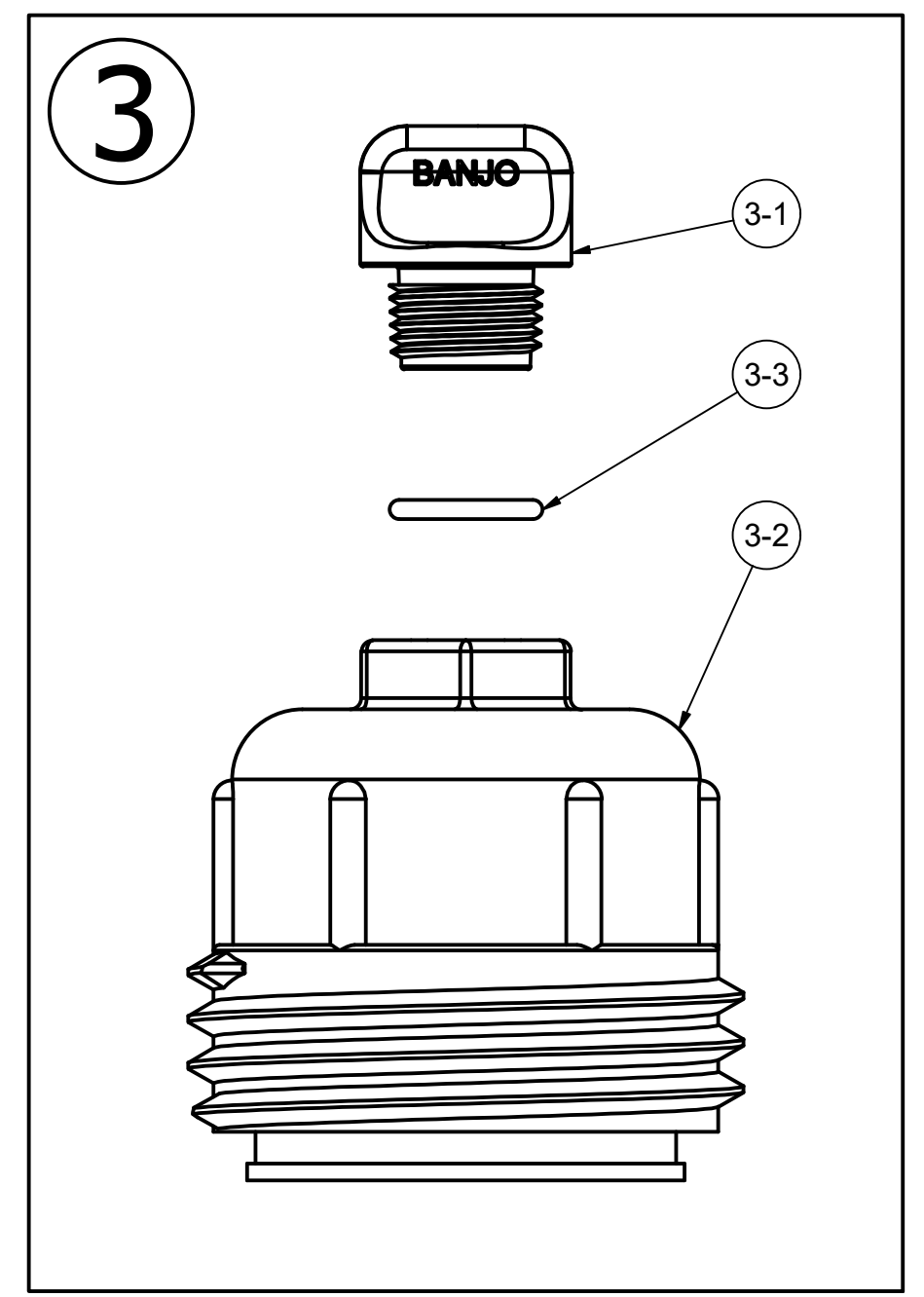

PARTS LIST

ITEM	QTY	PART NUMBER	DESCRIPTION
1	1	CE050D	CE DECAL
2	1	LS100-B	1" LINE STRAINER BODY
3	1	LS100-C1	LINE STRAINER CAP ASSY
3-1	1	12777	1/2" DRAIN PLUG
3-2	1	LS100XC1	1" LINE STRAINER CAP
3-3	1	UV15163	AS568A -114 O-RING, EPDM, BROWN
4	1	LS100-G	AS568A -228 O-RING, EPDM, BLACK
5	1	LS120	1" LS SCREEN - 20 MESH
6	1	LST1200D	200 PSI DECAL

SECTION B-B
SCALE 1:1

THIS DRAWING AND ALL INFORMATION CONTAINED THEREON ARE THE EXCLUSIVE PROPERTY OF BANJO CORPORATION.
UNLESS SPECIFICALLY NOTED, THIS DRAWING AND ITEMS SHOWN ON THIS DRAWING ARE SUBJECT TO CHANGE AT ANY TIME.



BANJO CORPORATION
150 BANJO DRIVE, CRAWFORDSVILLE, IN 47933
WEB SITE: WWW.BANJO.CORP.COM
E-MAIL: BANJOSALES@DEXCORP.COM

DESCRIPTION
1"LINE STRAINER 20 MESH SCREEN

PART NUMBER
LS100-20