

PARTS LIST			
ITEM	QTY	PART NUMBER	DESCRIPTION
1	1	CE050D	CE DECAL
2	1	LS050-B	1/2" LINE STRAINER BODY
3	1	LS075-C1	NEW 3/4" LINE STRAINER CAP
3-1	1	12723	1/4" PIPE PLUG
3-2	1	12724	AS568A -014 O-RING, EPDM, BLACK
3-3	1	LS075XC1	1/2" & 3/4" LINE STRAINER CAP
4	1	LS075-G	AS568A -221 O-RING, EPDM, BLACK
5	1	LS720	3/4" LS SCREEN - 20 MESH
6	1	LST1225D	225 PSI DECAL

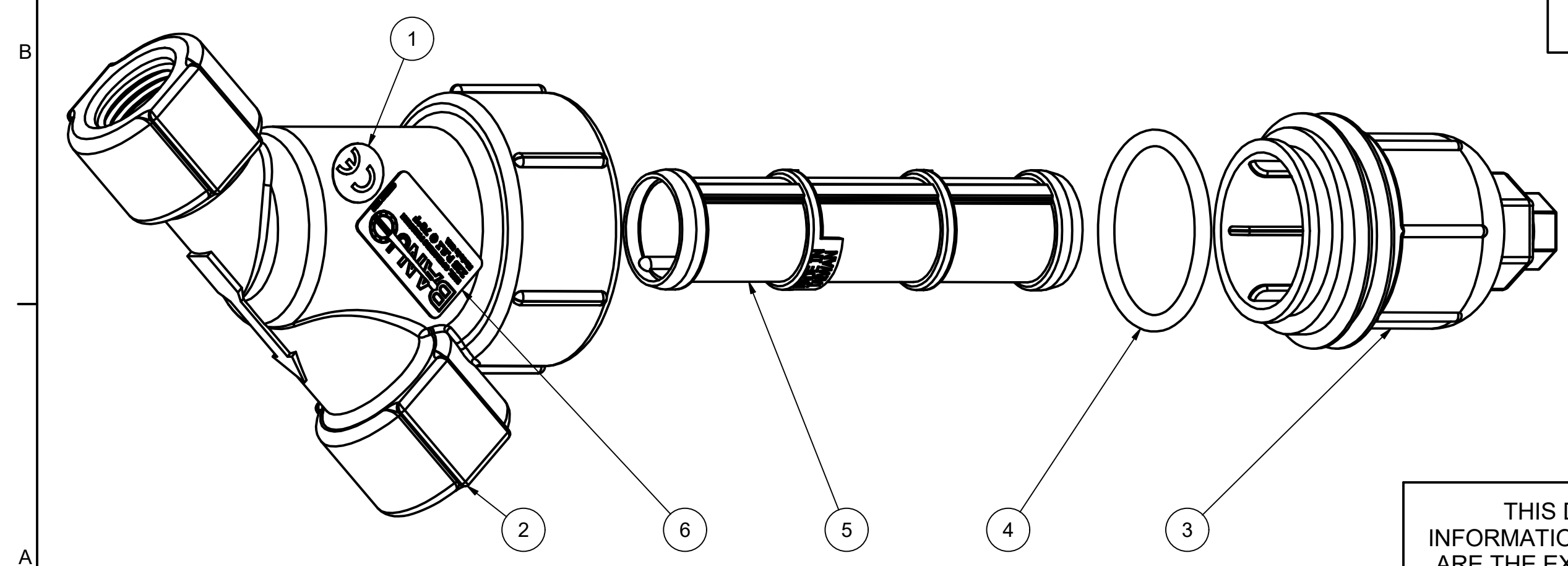

THIS DRAWING AND ALL INFORMATION CONTAINED THEREON ARE THE EXCLUSIVE PROPERTY OF BANJO CORPORATION.

UNLESS SPECIFICALLY NOTED, THIS DRAWING AND ITEMS SHOWN ON THIS DRAWING ARE SUBJECT TO CHANGE AT ANY TIME.

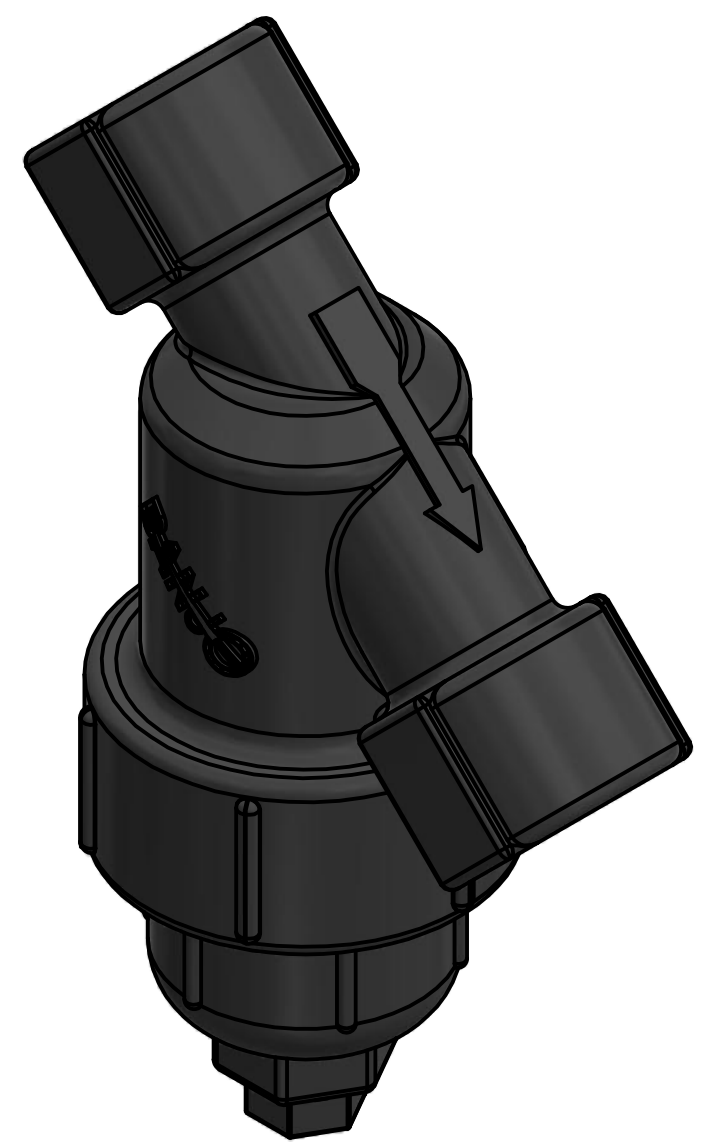
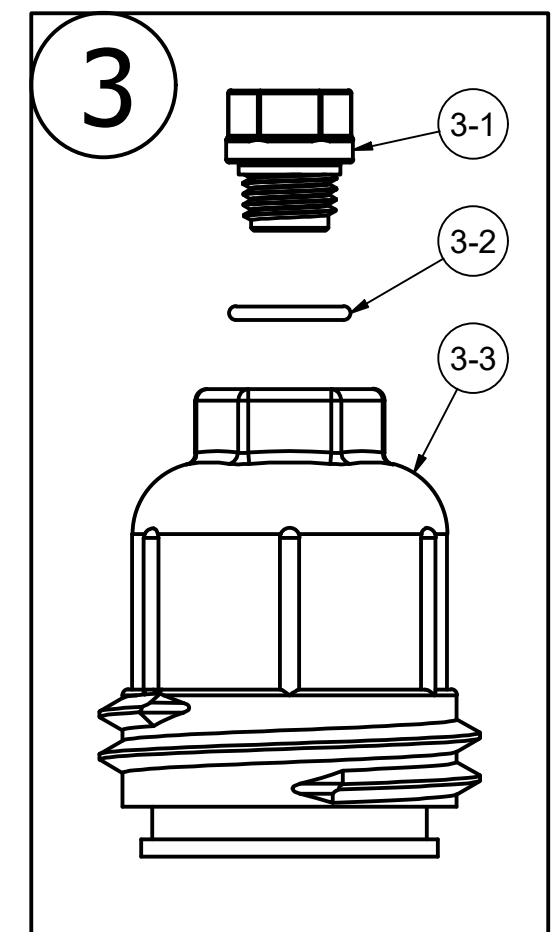

BANJO CORPORATION

BANJO CORPORATION
 150 BANJO DRIVE, CRAWFORDSVILLE, IN 47933
 WEB SITE: WWW.BANJOCORP.COM
 E-MAIL: BANJOSALES@IDEXCORP.COM

DESCRIPTION
1/2" LINE STR 20 MESH

PART NUMBER
LS050-20