

\*NOTE:  
8" ADDITIONAL CLEARANCE  
REQ'D FOR SCREEN REMOVAL.

SECTION B-B  
SCALE 1 : 1

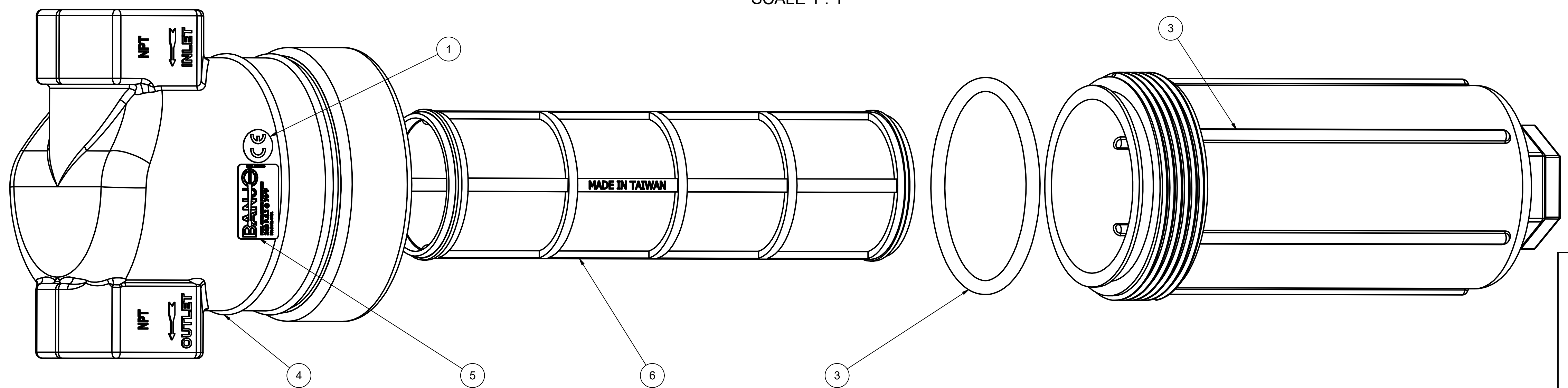

PARTS LIST			
ITEM	QTY	PART NUMBER	DESCRIPTION
1	1	CE050D	CE DECAL
2	1	LST150-B	1 1/2" T-Strainer Bowl Assembly
2-1	1	LSQ200-PL	1" NPT LINE STRAINER PLUG
2-2	1	LSQ200-R	AS568A -123 O-RING, EPDM, BLACK
2-3	1	LST150-XB	1 1/2" T-STRAINER BOWL
3	1	LST150-G	AS568A -336 O-RING, EPDM, BLACK
4	1	LST150-H	1 1/2" T-STRAINER HEAD
5	1	LST1300D	300 PSI DECAL
6	1	LST1580	1 1/2" LST SCREEN - 80 MESH



THIS DRAWING AND ALL INFORMATION CONTAINED THEREON ARE THE EXCLUSIVE PROPERTY OF BANJO CORPORATION.  
UNLESS SPECIFICALLY NOTED, THIS DRAWING AND ITEMS SHOWN ON THIS DRAWING ARE SUBJECT TO CHANGE AT ANY TIME.

BANJO CORPORATION  
150 BANJO DRIVE, CRAWFORDSVILLE, IN 47933  
WEB SITE: WWW.BANJO.CORP.COM  
E-MAIL: BANJOSALES@DEXCORP.COM

DESCRIPTION  
1-1/2" POLY T STRAINER 80 MESH

PART NUMBER  
LST150-80