

**ENERGIZER EN91**  
Industrial

**AA**

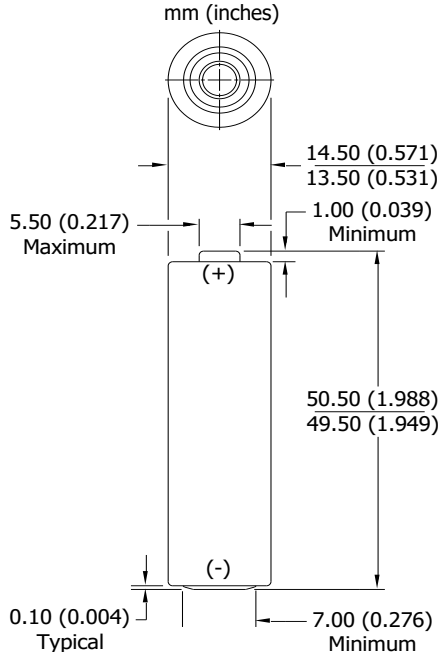

**Industry Standard Dimensions**



**General Information**

**Classification:** Alkaline  
**Chemical System:** Zinc-Manganese Dioxide (Zn/MnO<sub>2</sub>)  
 No added mercury or cadmium  
**Designation:** ANSI-15A, IEC-LR6  
**Nominal Voltage:** 1.5 volts  
**Operating Temp:** -18°C to 55°C (0°F to 130°F)  
**Typical Weight:** 24.0 grams  
**Typical Volume:** 8.1 cubic centimeters  
**Shelf Life:** 10 years at 21°C  
**Terminal:** Flat Contact

**Milliamp-Hours Capacity**

Continuous discharge to 0.8 volts at 21°C

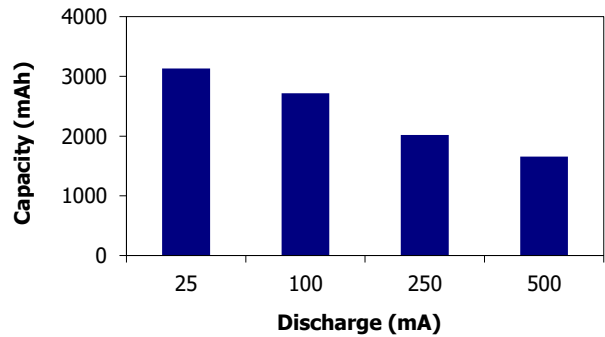

**Industry Standard Tests (21°C)**

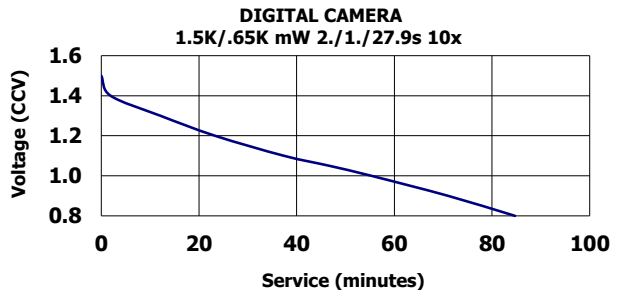
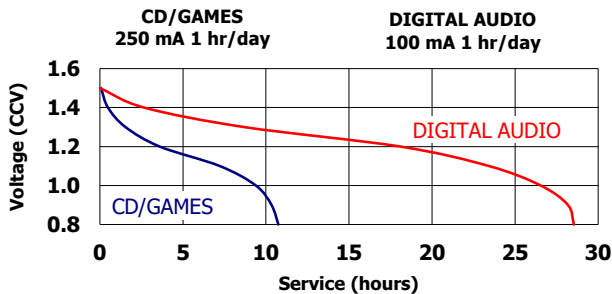
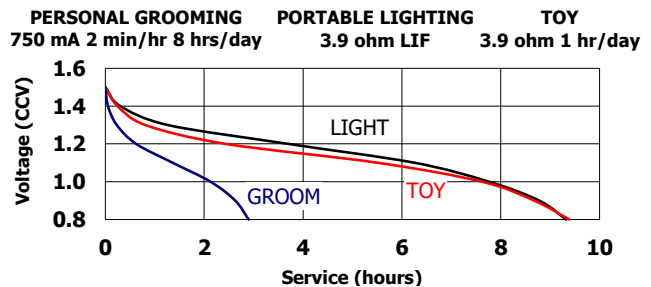
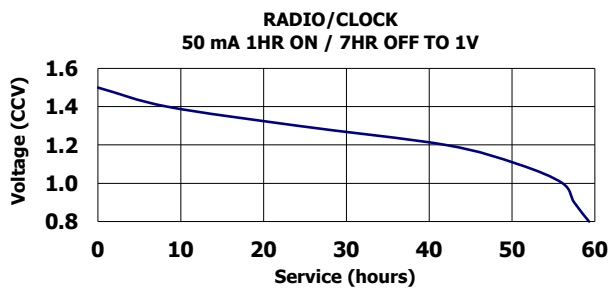

**Important Notice**

This datasheet contains typical information specific to products manufactured at the time of its publication.  
**Contents herein do not constitute a warranty and are for reference only.**