

Weldcraft™ W-375

Hand-Held Water-Cooled
TIG Welding Torches



Quick Specs

Model

W-375 Super Cool

Applications

Aerospace
Aluminum Fabrication
Aluminum Ship Repair
Automotive
Exotic Material Fabrication
Light and Heavy Manufacturing
Maintenance and Repair

Pipe and Tube Fabrication
Precision Metal Fabrication
Pressure Vessel Fabrication
Shipbuilding
Tool and Die
Tube and Pipe
Vocational

Rated Output

DC: 375 A, AC: 265 A

Duty Cycle 100%

Electrode Range

.020–1/8 in. (0.5–3.2 mm)

W-375 Super Cool™ TIG Torch

The W-375 Super Cool is a reliable water-cooled torch designed for demanding, high-amperage applications. The W-375 Super Cool is engineered with innovative technology and welding efficiency in mind.

Super Cool technology provides additional surface area to increase cooling efficiency and capacity.

Reduce downtime due to overheating through consistent water-cooled performance.

Extend torch life with dependable water-cooled technology.

Reduce leakage of gas and water through secure connections in the mechanical fittings.

Note: Torch delivered may vary slightly from image shown.



W-375 Super Cool
(#301 253)



Torch is warranted for 1 year parts.



Miller Electric Mfg. Co.

An ITW Welding Company
1635 West Spencer Street
P.O. Box 1079
Appleton, WI 54912-1079 USA

Equipment Sales US and Canada

Phone: 866-931-9730
FAX: 800-637-2315
International Phone: 920-735-4554
International FAX: 920-735-4125

MillerWelds.com



Torch Packages

Models	Braided Rubber		Braided Rubber with 50 mm Dinse
Name	12.5 ft. (3.8 m)	25 ft. (7.6 m)	25 ft. (7.6 m)
W-375 Super Cool™	#301 253 012	#301 253 025	#301 253 001*

Torch packages include torch body, handle, power cable, gas hose, water hose, and long back cap.

*Cable cover included.

Connectors

Power Cable Connectors



195 380
50-mm Dinse-style gas thru with gas and water return lines for water-cooled torch.



195 377
50-mm Dinse-style with water return line for water-cooled torch.



45V11
Power cable adapter for water-cooled torch.



225 028
50-mm thread-lock-style for water-cooled torch.

Machines	Connection Type	1-Piece Power Cable Connector
TIG Machines		
Syncrowave® 200/210	50-mm Dinse, Gas Thru	195 380
Syncrowave® 250 DX/350 DX (Dinse)	50-mm Dinse	195 377
Syncrowave® 250 DX/350 DX (Stud)	1/2-in. Stud	45V11
Dynasty® 200/280/350, Maxstar® 200/280/350	50-mm Dinse	195 377
Dynasty® 700, Maxstar® 700	50-mm Thread-Lock	225 028
Multiprocess Machines		
Dimension™ 302/452/NT 450/652	1/2-in. Stud	45V11
PipeWorx	1/2-in. Stud	45V11
XMT® 304/350	50-mm Dinse	195 377
XMT® 450	1/2-in. Stud	45V11
Engine-Driven Machines		
Most Big Blue®, Trailblazer®, Bobcat™, Blue Star® and Wildcat® models	1/2-in. Stud	45V11
Big Blue® 450 Duo CST	50-mm Dinse	195 377
General Reference		
	50-mm Dinse	195 377
	50-mm Dinse, Gas Thru	195 380
	50-mm Thread-Lock	225 028
	1/2-in. Stud	45V11
Other Adapter		
	Stud to Dinse Adapter	232 728

Consumables (Refer to Owner's Manual for additional replacement parts.)

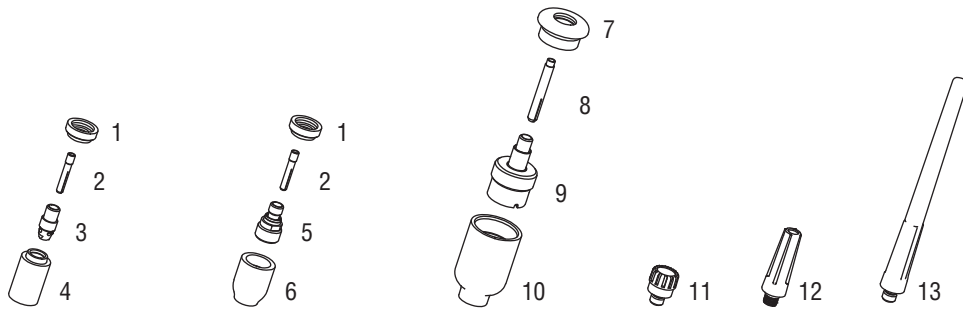

Non-Gas Lens

Electrode Size — inch (mm)	.020 (0.5)	.040 (1.0)	1/16 (1.6)	3/32 (2.4)	1/8 (3.2)				
1 Insulator (required)	598882	598882	598882	598882	598882				
2 Collet	13N20	13N21	13N22	13N23	13N24				
3 Collet Body	13N25	13N26	13N27	13N28	13N29				
Nozzle Size — size # (inch)	3 (3/16)	4 (1/4)	5 (5/16)	6 (3/8)	7 (7/16)	8 (1/2)	10 (5/8)	12 (3/4)	Short
4 Alumina	—	13N08	13N09	13N10	13N11	13N12	13N13	—	—
* Lava	—	13N14	13N15	13N16	13N17	13N18	13N19	—	—
* Long Lava	796F70	796F71	796F72	796F73	—	—	—	—	—
* X-Long Lava	796F74	796F75	796F76	796F77	—	—	—	—	—

Gas Lens

Electrode Size — inch (mm)	.020 (0.5)	.040 (1.0)	1/16 (1.6)	3/32 (2.4)	1/8 (3.2)				
1 Insulator (required)	598882	598882	598882	598882	598882				
2 Collet	13N20	13N21	13N22	13N23	13N24				
5 Gas Lens	45V41	45V42	45V43	45V44	45V45				
Nozzle Size — size # (inch)	3 (3/16)	4 (1/4)	5 (5/16)	6 (3/8)	7 (7/16)	8 (1/2)	10 (5/8)	12 (3/4)	Short
6 Alumina Gas Lens	—	53N58	53N59	53N60	53N61	53N61S	—	—	—

Large Diameter Gas Lens

Electrode Size — inch (mm)	.020 (0.5)	.040 (1.0)	1/16 (1.6)	3/32 (2.4)	1/8 (3.2)				
7 Insulator (required)	54N63-20	54N63-20	54N63-20	54N63-20	54N63-20				
8 Collet	13N20L	13N21L	13N22L	13N23L	13N24L				
9 Large Diameter Gas Lens	45V0204S	45V0204S	45V116S	45V64S	995795S				
Nozzle Size — size # (inch)	3 (3/16)	4 (1/4)	5 (5/16)	6 (3/8)	7 (7/16)	8 (1/2)	10 (5/8)	12 (3/4)	Short
10 Large Dia. Gas Lens	—	—	—	57N75	—	57N74	53N88	53N87	53N89
* Large Dia. Gas Lens-L	—	—	—	57N75L	—	57N74L	53N88L	53N87L	—
* Large Dia. Gas Lens-XL	—	—	—	57N75XL	—	57N74XL	53N88XL	53N87XL	—
* Large Dia. Gas Lens-XXL	—	—	—	57N75XXL	—	57N74XXL	53N88XXL	53N87XXL	—

Back Caps

11 Short 41V33 12 Medium 41V35 13 Long 41V24

*Not shown.

Tungsten

Tungsten for the Most Demanding TIG Welding Applications!

Available in four types and industry-standard diameters, our line of Weldcraft™ tungsten electrodes has undergone rigorous testing to ensure the highest quality and durability. Color-coded packages include ten seven-inch (175 mm) tungsten electrodes.

Note: Refer to manufacturer MSDS sheets for proper preparation and safety. Use proper ventilation/capture during preparation. Refer to manufacturer warning regarding ventilation.



Type	Diameter in. (mm)	Part #	Type	Diameter in. (mm)	Part #
2% Ceriated (EWCe-2)			Pure (EWP)		
Performs well in DC welding and arc starting at low-current settings, and offers excellent performance in AC processes.	0.040 (1.0)	WC040X7	Forms a clean, balled end when heated and provides good arc stability for AC welding with a balanced or unbalanced squarewave or sine wave.	0.040 (1.0)	—
	1/16 (1.6)	WC116X7		1/16 (1.6)	WP116X7
	3/32 (2.4)	WC332X7		3/32 (2.4)	WP332X7
	1/8 (3.2)	WC018X7		1/8 (3.2)	WP018X7
	5/32 (4.0)	WC532X7		5/32 (4.0)	—
2% Lanthanated (EWLa-2)			Rare Earth (EWG)		
Provides excellent arc starting, arc stability and re-ignition, and less tip erosion in AC or DC welding. Can substitute for 2% Thoriated.	0.040 (1.0)	WL2040X7	Combines the best of all alloying elements, and provides excellent arc stability in AC or DC welding.	0.040 (1.0)	—
	1/16 (1.6)	WL2116X7		1/16 (1.6)	WG116X7
	3/32 (2.4)	WL2332X7		3/32 (2.4)	WG332X7
	1/8 (3.2)	WL2018X7		1/8 (3.2)	WG018X7
	5/32 (4.0)	WL2532X7		5/32 (4.0)	—

Genuine Miller® Accessories



Wireless Remote Foot Control #300 429

For remote current and contactor

control. Receiver plugs directly into the 14-pin receptacle of Miller machine. 90-foot (27.4 m) operating range.



Wireless Remote Hand Control #300 430

For remote current and contactor control. Receiver plugs directly into the 14-pin receptacle of Miller

machine. 300-foot (91.4 m) operating range.



RCCS-14 Remote Contactor and Current Control #043 688

North/south rotary-motion fingertip control attaches to TIG torch using two hook-and-loop fasteners. Includes 26.5-foot (8 m) control cord and 14-pin plug.



RCC-14 Remote Contactor and Current Control #151 086

East/west rotary-motion fingertip control attaches to TIG torch using two hook-and-loop fasteners. Includes 26.5-foot (8 m) cord and 14-pin plug.



Cable Covers

#WC0183 11.75 ft. (3.6 m)
For use with torch package #301 253 012.

#WC0182 24.25 ft. (7.4 m)
For use with torch packages #301 253 025 and #301 253 001.

Extension Kit

#EK-1-25-R 25 ft. (7.6 m), rubber



Low-Conductivity TIG Coolant #043 810

Sold in multiples of four in one-gallon recyclable plastic bottles. Miller coolants contains a base

of ethylene glycol and deionized water to protect against freezing to -37° Fahrenheit (-38° C) or boiling to 227° Fahrenheit (108° C).



#AK4C Accessory Kit

Includes one long back cap, one of each size (#5, #6, #7) alumina nozzle, and one of each size (1/16, 3/32, 1/8 inch) of the following: collet, collet body, and 7-inch 2% ceriated tungsten electrode.

Distributed by:

