



Whitehall Manufacturing®
Manufacturer of Healthcare and Rehabilitation Products since 1946

**Ligature Resistant
Stainless Steel Basin
Powder Coated White
ADA Compliant
Model WH3740**



WH3740-WH3374

**INSTALLATION, OPERATIONS AND
MAINTENANCE MANUAL**



IMPORTANT

Important: Some options may slightly alter installation. To ensure proper installation review the manual thoroughly and verify rough-ins before beginning any work. File this manual with the owner or maintenance personnel upon completion of installation.

Industry standard wall backing, for wall hung fixtures, is required. Installer provided wall anchors and wall anchoring hardware with a minimum Pull-Out Force of 1000 pounds (lbs) per anchor for appropriate wall construction.

ANSI, UFAS or ADA compliance is subject to the interpretation and requirements of the local code authority and is the responsibility of the installer for verification.

Single Temp Valve Assembly: Recommended working water pressure is 30 psi (2.07 bars) minimum to 100 psi (6.89 bars) maximum. Maximum temperature is 130°F (54.4°C). Maximum outlet temperature recommended is 105°F (40.6°C). Valve assembly must be drained prior to being subjected to freezing temperatures.

T/P Mixing Valve Assembly: Recommended working water pressure is 30 psi (2.07 bars) minimum to 100 psi (6.89 bars) maximum. Maximum hot water temperature is 180°F (82°C). Temperature adjustment range is 85-115°F (29-46°C). Minimum hot water supply temperature must be 5°F (3°C) above desired set temperature. Valve assembly must be drained prior to being subjected to freezing temperatures. The valve assembly has checks integral to the inlets however, angle stops are to be provided by the installer.

Prior to installation, supply lines must be flushed of all foreign material such as pipe dope, chips, or solder. Debris or foreign material in water supply may damage valve.

Teflon tape is recommended on all threaded waste and supply connections to reduce the possibility of leaks.

Provide 110-120VAC/60Hz/3A (MAX) electrical receptacle for factory supplied 120VAC/9VDC, 100mA plug-in transformer if required.

NOTE: Receptacle(s) must be wired to a GFCI protected circuit. Fixture must be earth grounded per N.E.C. (National Electrical Code).

Upon receiving, verify count and inspect packaging for obvious signs of damage or missing containers. If there are any issues upon receiving make note on bill of lading and report to carrier and manufacturer promptly. Remove fixture assemblies from packaging and ensure all parts are present before beginning installation. Do not discard packaging until all parts have been accounted for. Refer to Acorn terms, conditions of sales and warranty for more information.



Table of Contents

	<u>PAGE</u>
Prior to Installation	a
Table of Contents	1
Accessibility Overview	2
Dimensional Data.....	3
Rough-Ins	4-6
Installation.....	7-13
Troubleshooting	14
Cleaning and Maintenance	15
Programming Piezo Pushbutton	16-18
Components & Repair Parts	19-21
Warranty Information.....	22

Required Items for Installation - Not Supplied

- | | |
|--|---|
| <ul style="list-style-type: none"> ✍ Chalk Line ✍ Hammer ✍ Carpenters Level ✍ 1/2" NPS Outlet Angle Stops ✍ 1/2" NPS Flexible Supply Hose
(For Dual Temperature with Tempering Valves Only) ✍ 5/8" Hex Wrench & 1/8" Allen Wrench for Temperature Adjustment | <ul style="list-style-type: none"> ✍ 1/8" Slotted Tip Screwdriver For Metering Adjustment ✍ Plumbers Putty ✍ Teflon Tape ✍ Fixture Wall Anchors and Anchoring Hardware (and Appropriate Tools) - For 9/16" (4 Places) & 9/32" (5 places) ✍ Driver For 5/32" Hex Driver Bit for Supplied Center Reject Screws |
|--|---|



ACCESSIBILITY OVERVIEW

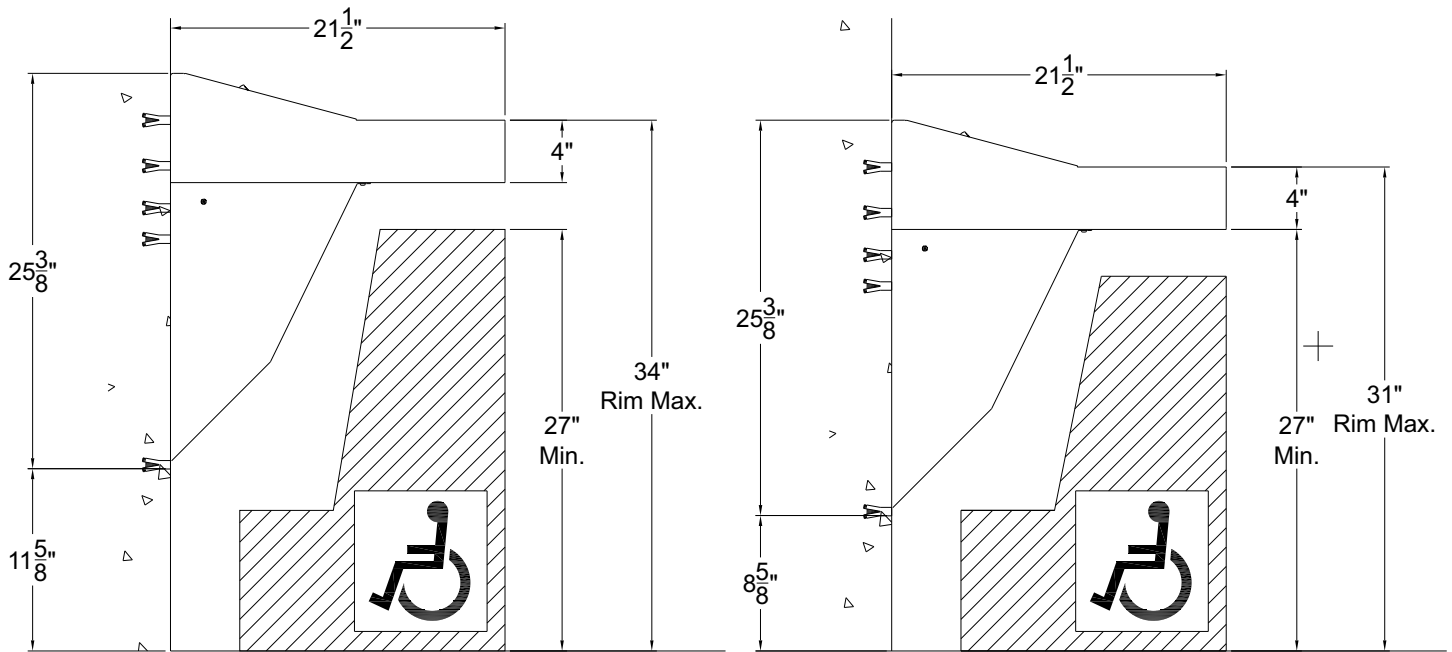

**ADA
Adult**



**ADA ages
6 thru 12**

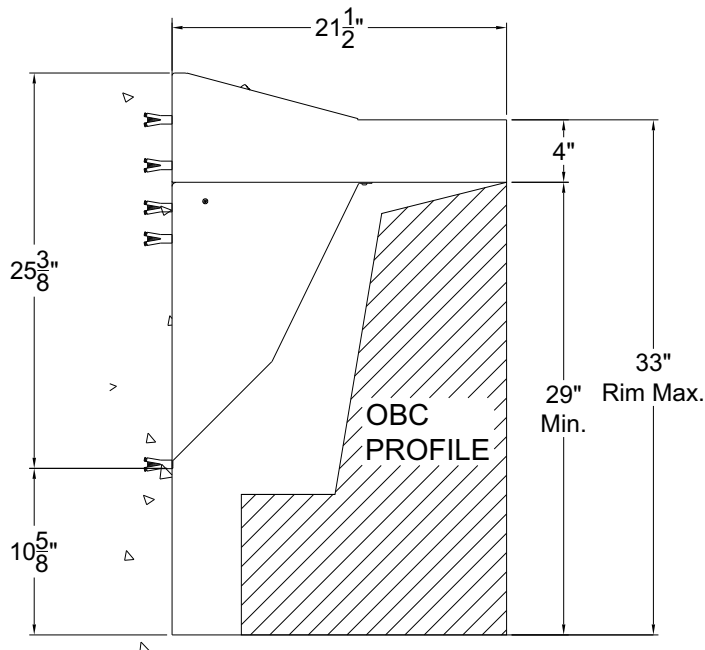

OBC



DIMENSIONAL DATA

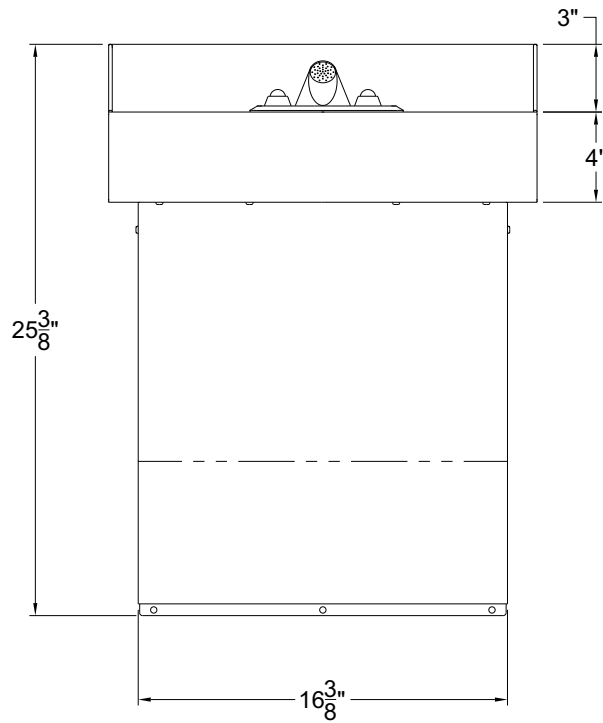
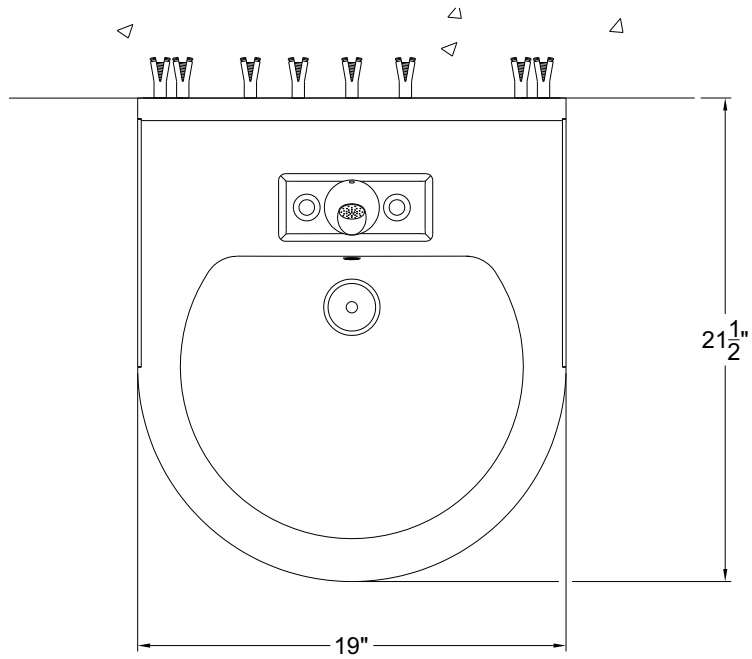



ROUGH-IN DIMENSIONS -ADA (Adult)

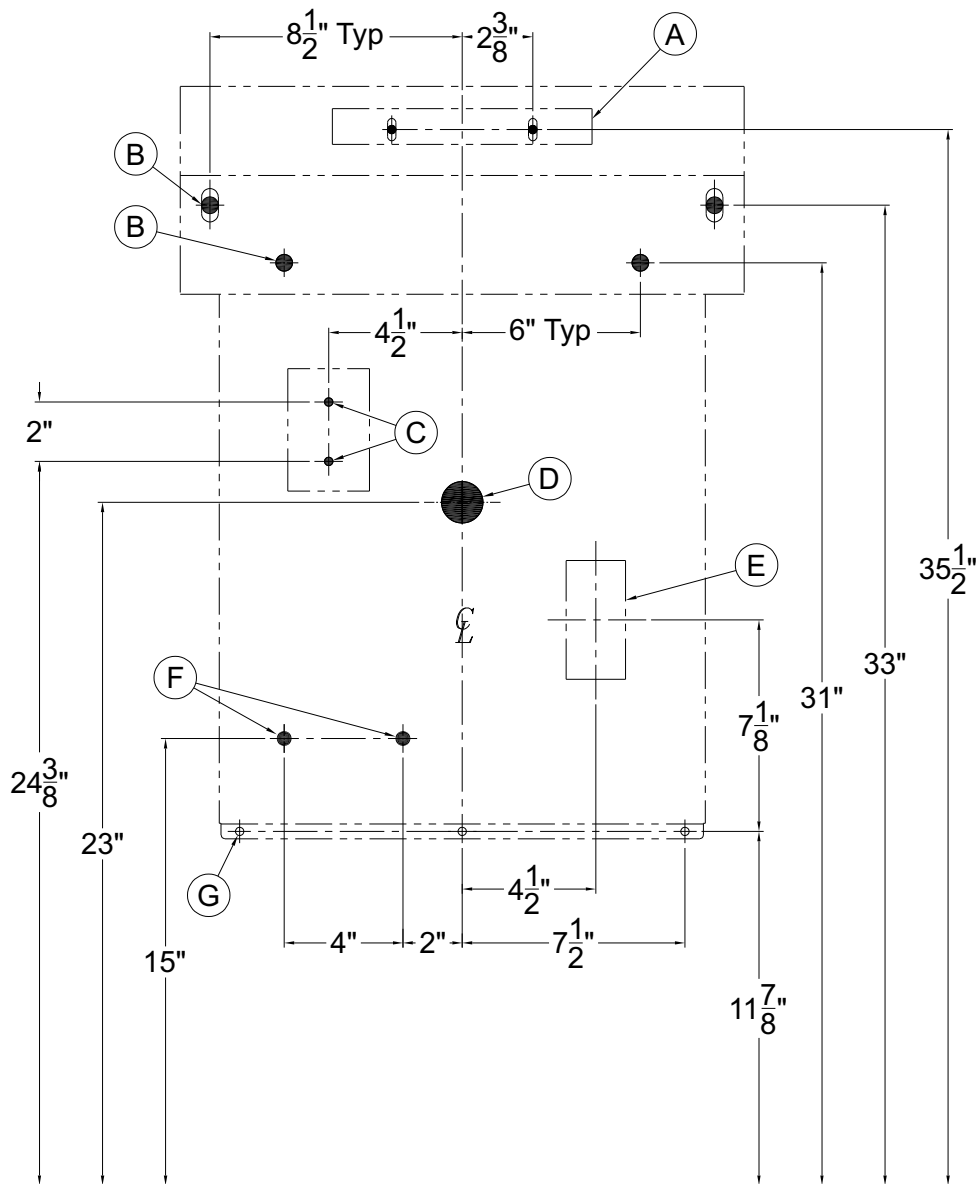

- (A) * Fixture Support Mounting - 8-3/4" Wide Mounting S-Clip w/ (2) Ø9/32" x 3/4" Long Mounting Slots for 1/4" Wall Anchors with min. Pull-Out Force of 1000 lbs per anchor.
- (B) * Fixture Support Mounting - (4) Ø9/16" Mounting Holes for 3/8" Wall Anchors with min Pull-Out Force of 1000 lbs per anchor.
- (C) (2) Ø9/32" Mounting Holes for Valve Mounting Bracket
- (D) Ø1-1/2" Tube Lavy Waste Outlet For Compression Joint
- (E) 120VAC, 60Hz, 3A (Max) GFCI Protected, Electrical Receptacle
- (F) 1/2" NPS Hot & Cold Angle Stops (By Others)
- (G) (3) Ø1/4" Mounting Holes

NOTE: Callouts with (*) requires proper backing to secure wall anchors for fixture support mounting.



ROUGH-IN DIMENSIONS -ADA AGES 6 THRU 12 YEARS

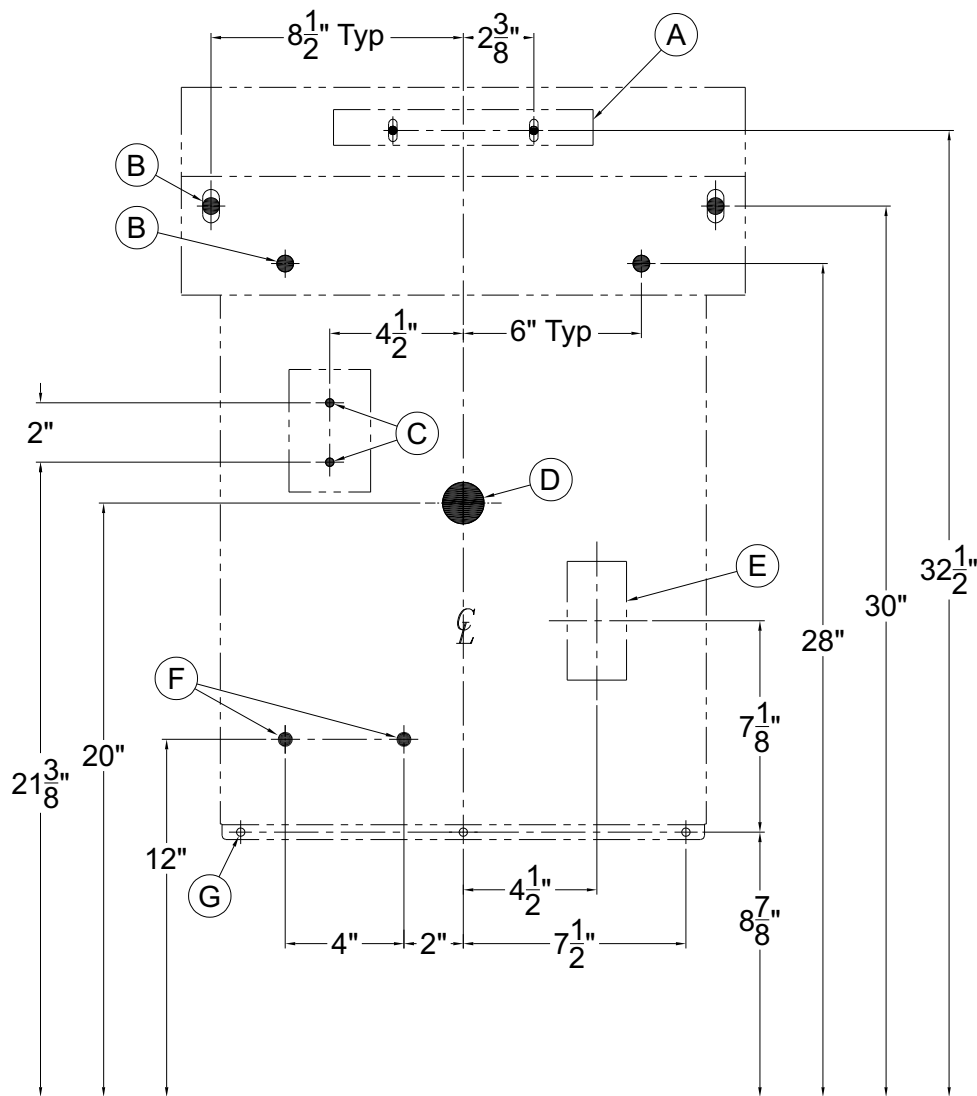

- (A) * Fixture Support Mounting - 8-3/4" Wide Mounting S-Clip w/ (2) Ø9/32" x 3/4" Long Mounting Slots for 1/4" Wall Anchors with min. Pull-Out Force of 1000 lbs per anchor.
- (B) * Fixture Support Mounting - (4) Ø9/16" Mounting Holes for 3/8" Wall Anchors with min Pull-Out Force of 1000 lbs per anchor.
- (C) (2) Ø9/32" Mounting Holes for Valve Mounting Bracket
- (D) Ø1-1/2" Tube Lavy Waste Outlet For Compression Joint
- (E) 120VAC, 60Hz, 3A (Max) GFCI Protected, Electrical Receptacle
- (F) 1/2" NPS Hot & Cold Angle Stops (By Others)
- (G) (3) Ø1/4" Mounting Holes

NOTE: Callouts with (*) requires proper backing to secure wall anchors for fixture support mounting.



ROUGH-IN DIMENSIONS -OBC

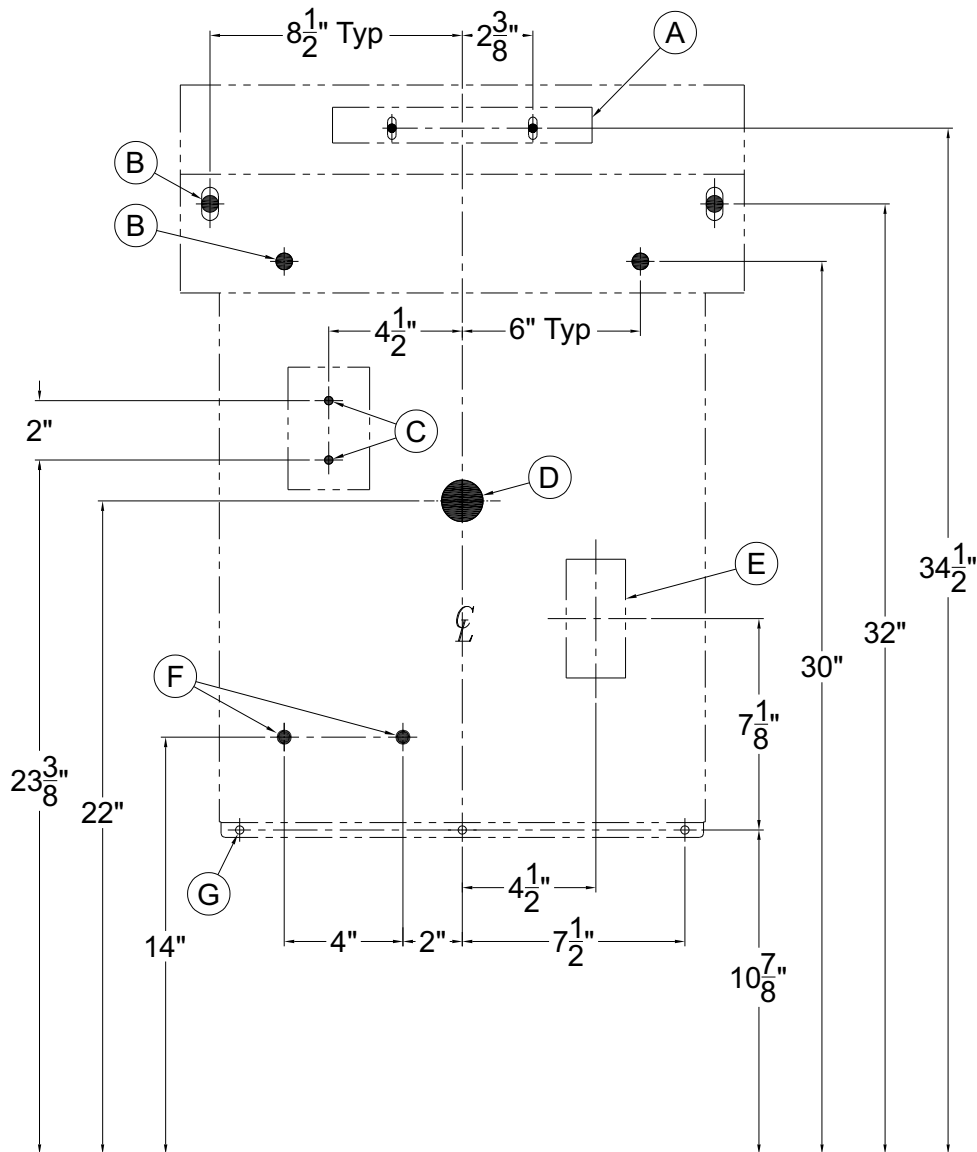

- (A) * Fixture Support Mounting - 8-3/4" Wide Mounting S-Clip w/ (2) Ø9/32" x 3/4" Long Mounting Slots for 1/4" Wall Anchors with min. Pull-Out Force of 1000 lbs per anchor.
- (B) * Fixture Support Mounting - (4) Ø9/16" Mounting Holes for 3/8" Wall Anchors with min Pull-Out Force of 1000 lbs per anchor.
- (C) (2) Ø9/32" Mounting Holes for Valve Mounting Bracket
- (D) Ø1-1/2" Tube Lavy Waste Outlet For Compression Joint
- (E) 120VAC, 60Hz, 3A (Max) GFCI Protected, Electrical Receptacle
- (F) 1/2" NPS Hot & Cold Angle Stops (By Others)
- (G) (3) Ø1/4" Mounting Holes

NOTE: Callouts with (*) requires proper backing to secure wall anchors for fixture support mounting.



FIXTURE ANCHORING

- 1 With trap enclosure removed, remove the valve assembly and anchor the valve mounting bracket and mounting S-Clip to the wall using mounting hardware by others, refer to dimensional data for rough-in information. For mounting S-Clip, 1/4" wall anchors with min. Pull-Out Force of 1000 lbs per anchor is required.

- 2 Once the valve mounting bracket is anchored to the wall, mount the valve assembly to the valve mounting bracket using mounting hardware provided by the installer.

- 3 Before anchoring basin to the wall remove waste assembly. After the waste assembly has been removed, install mounting hardware to fixture. Center and butt the basin to the finished wall. Slide down the basin so basin and mounting S-Clip engages. 3/8" wall anchors with min. Pull-Out Force of 1000 lbs per anchor required for fixture mounting. Assemble waste assembly and make appropriate connections. Test for leaks for usage.

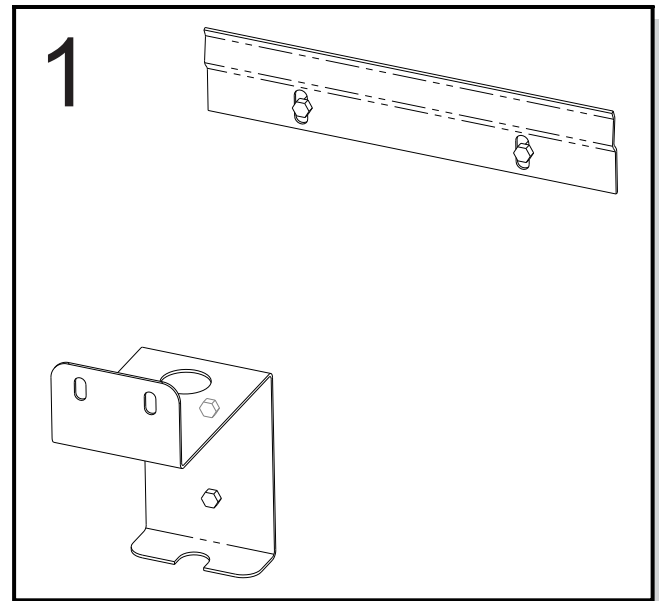

HINT: It may be advantages to install deck trim such as faucets, soap dispensers or other accessories prior to wall mounting.

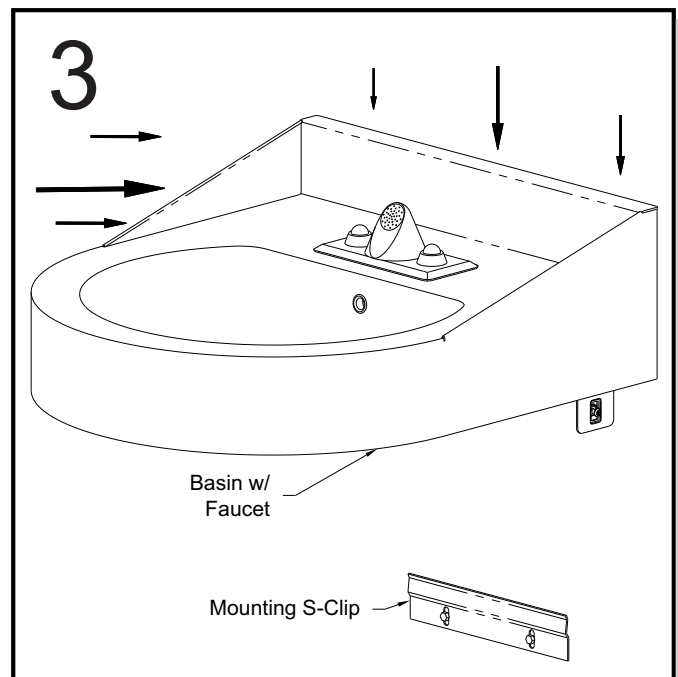
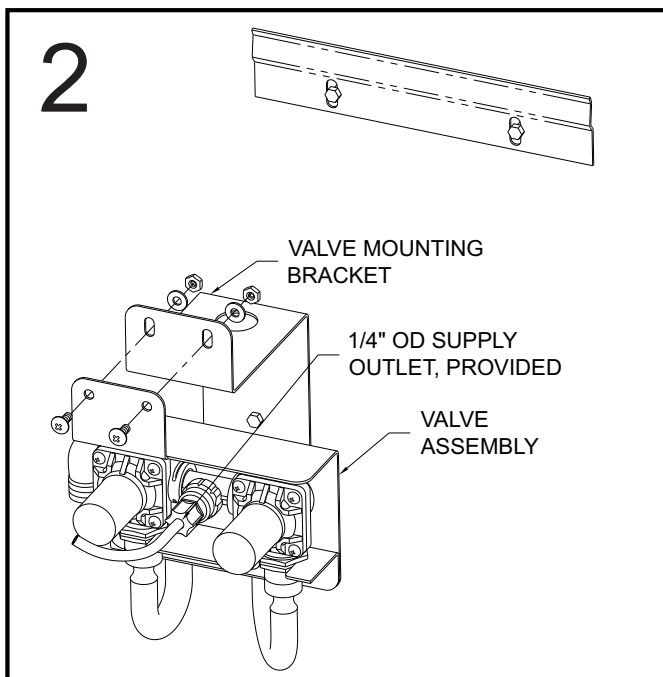



WASTE ASSEMBLY



HINT: Teflon tape is recommended on all threaded waste and supply connections.

4 Install strainer to basin using plumbers putty on underside of grid strainer flange. Insert the Overflow Insert through the Overflow Hole and tighten to 3/8" O.D. Elbow Adapter. From beneath basin, assemble rubber gaskets, overflow adapter, fiber gasket and jam nut as shown to strainer and tighten securely. Add close elbow to strainer assembly as indicated.

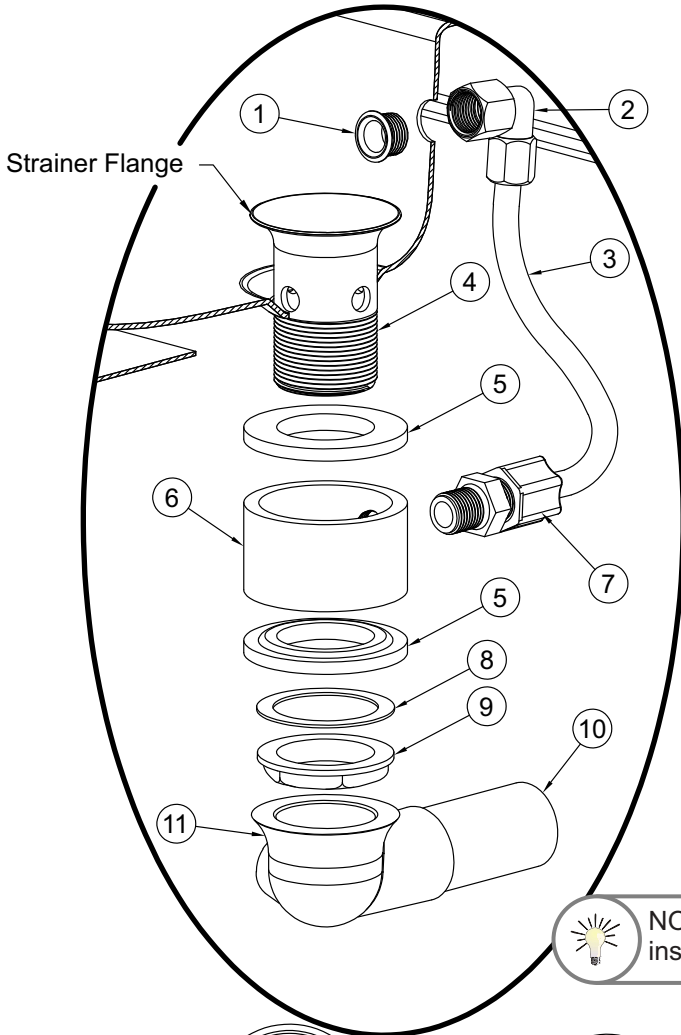

- ① Overflow Insert
- ② 3/8" O.D. x 3/8" NPT Female Connection
- ③ 3/8" O.D. Overflow Tube
- ④ Strainer w/ 1-1/2" - 16 UNE Threads
- ⑤ Rubber Gasket
- ⑥ Overflow Adapter
- ⑦ 3/8" O.D. x 3/8" NPT Male Connection
- ⑧ Red Flat Fiber Gasket
- ⑨ 1-1/2" - 16 UNI Rough Chrome Brass Nut
- ⑩ Waste Outlet Connection
- ⑪ 1-1/4" - 27 UNI Close Ell w/ 3/8" NPTI Clean-Out Plug



NOTE: Waste assembly may require field cutting and fitting by the installer.

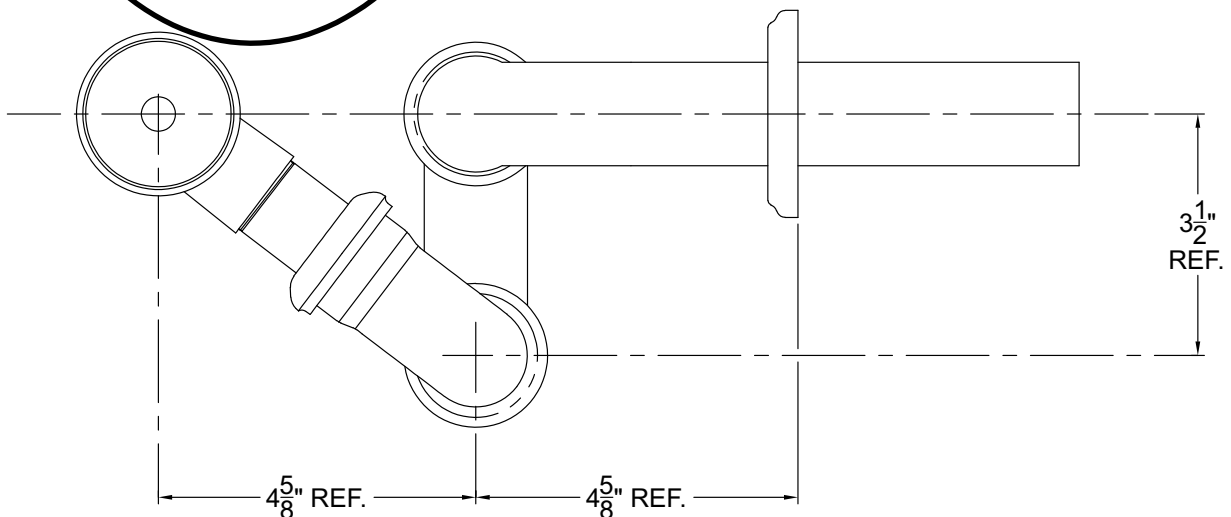

5 Assemble waste piping using teflon tape on all threaded connections and make up waste connections to 1-1/2" P-trap.



VALVE INSTALLATION



Before making up the supply connections, the supply lines must be flushed of all foreign material such as pipe dope, pipe chips, solder, sand, etc.

-03-M SINGLE TEMPERATURE METERING VALVE

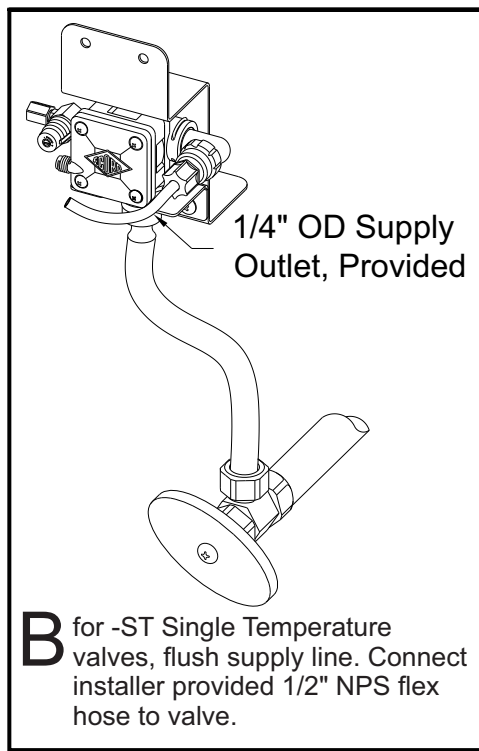

DUAL TEMP. WITH MX-TP VALVE

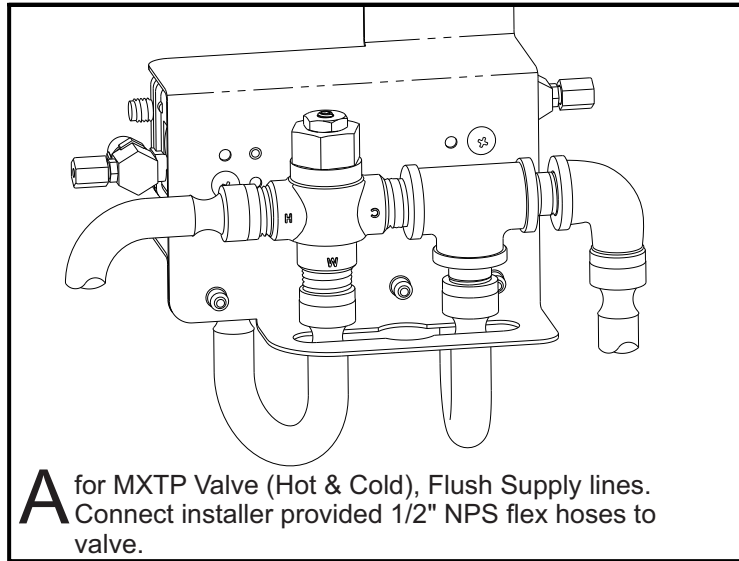

-04-M HOT & COLD METERING VALVE

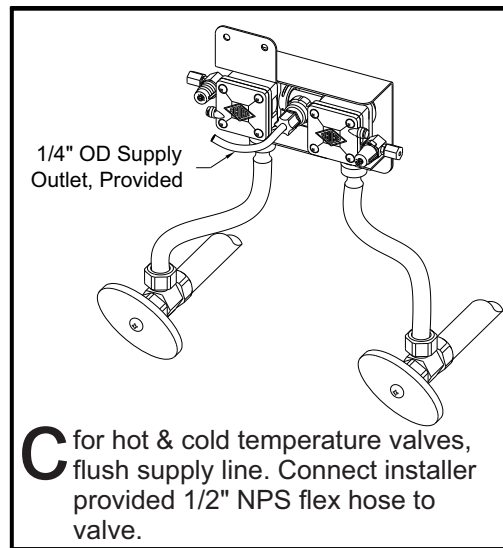

Valve Assembly Installation:

NOTE: Installation should be in accordance with accepted plumbing practices. Angle stops are recommended and is the responsibility of the installer

- 1) Locate suitable place for mounting the valve assembly. Valve assembly should be accessible for service and adjustment and as close to the point-of-use as possible. Wall anchors and anchoring hardware, for \varnothing 3/8" mounting holes, provided by installer.
- 2) Connect hot and cold water to supply valve using 1/2" NPTE connections.
- 3) Connect outlet of tempering valve to spout(s) using 1/4" OD tubing and adapter.
- 4) Turn on hot and cold water supplies. If any leaks are observed, hand tighten connections as necessary to stop leaks before proceeding.

-MXTP VALVE ONLY

- 5) Turn on fixture and allow water to flow for 2 minutes. Measure water temperature at outlet. If water is not at desired temperature, adjust as necessary.



VALVE ADJUSTMENT & SERVICING

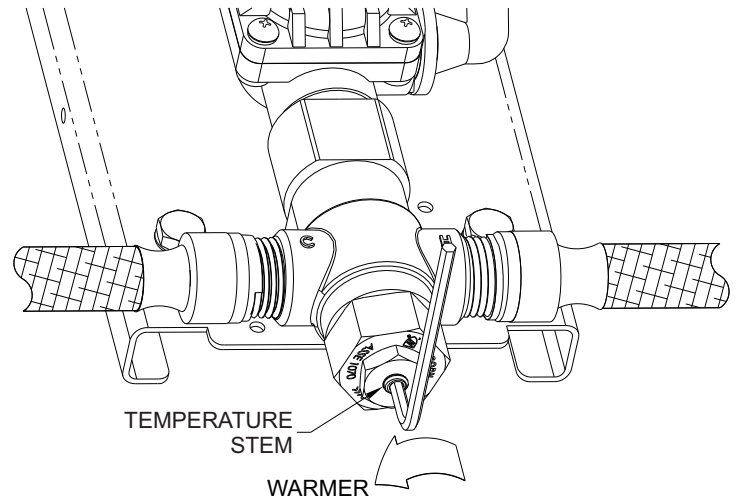
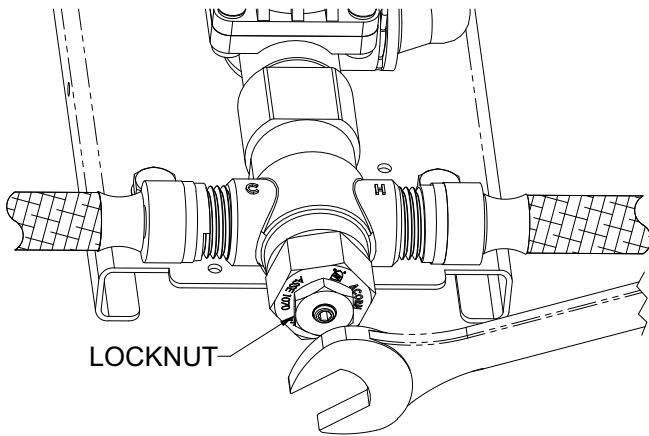

Temperature Adjustment:

- 1) Loosen locknut.
- 2) Turn on fixture and run water for at least 2 minutes. Allow supply temperature to stabilize.
- 3) Turn temperature stem counter-clockwise for hotter or clockwise for colder outlet temperature.
- 4) Tighten locknut to prevent accidental or unauthorized temperature adjustment.
- 5) Re-check outlet temperature.

Cleaning Valve Screen:

Before starting process shut-off water supply and activate water valve to depressurize the water line.

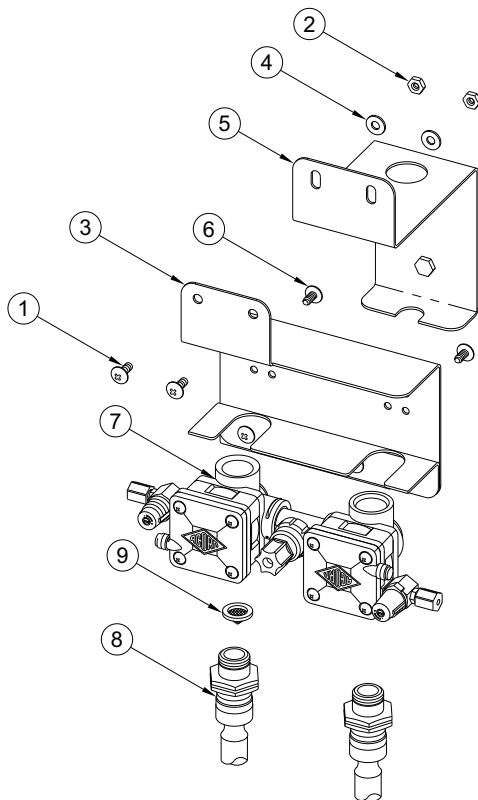

- 1) Disconnect supply hose(s) from stops.
- 2) Using a Phillips screw driver remove #10-32 phillips screws ① while using a 3/8 wrench to retain #10-32 hex nuts ② to free valve assembly with valve bracket ③. Once screws, nuts and washers ④ have been removed place in a safe place for reassembly.
- 3) With valve assembly free from wall bracket ⑤ remove #10-32 phillips screw(s) ⑥ from the back of the valve bracket ③ to allow valves ⑦ to be free.
- 4) With valves completely loose pull out adapter with supply hoses ⑧ from valves in order to get access to the screen washer ⑨. The screen washer should remain inside of the valve opening and easy to remove for servicing.
- 5) Reassemble in reverse order
- 6) Completely flush supply lines of all foreign debris before reconnecting to fixture.
- 7) Air within the valve assembly or the structure supply piping will cause an irregular outlet stream until purged out by incoming water. Covering the spout with a clean cup (or similar object) is recommended when first activating the valve assembly to prevent excessive splashing. Activate valve assembly until steady water is achieved.



VALVE CONNECTIONS

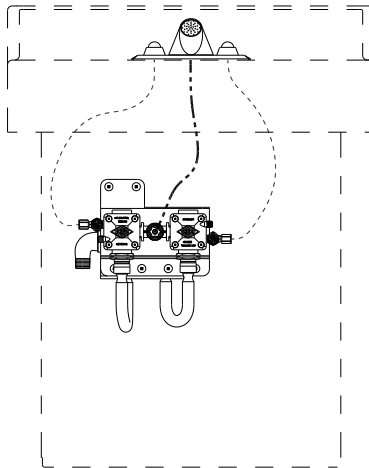

----- 1/8" O.D. AIR TUBE
 _____ 1/4" O.D. WATER TUBE

! IMPORTANT

Leave a minimum 1/4" of polyethylene tubing protruding through the Ferrule Nut. This is necessary to ensure proper tubing connection.

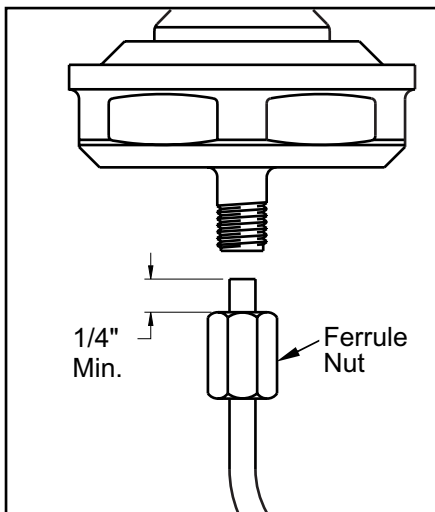

Ferrule Nut
 Timing Screw
 To adjust timing, turn timing screw.

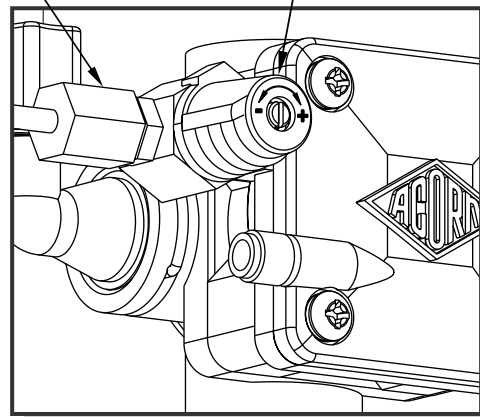

Turn timing screw clockwise to increase timing.

! IMPORTANT

Do not over tighten ferrule nuts.



SENSOR OPERATION & CONNECTIONS

-SO Sensor Operation Range Adjustment

1. Make sure power supply is disconnected from sensor and make short circuit on red wires. See DETAIL A.
2. Connect power supply to sensor. Red light should be flashing.
3. Move hand in front of sensor to distance of 2" to 4" within 5 seconds and wait until red light flashes quickly.
4. Move hand to desired sensing distance. See DETAIL B.
5. Hold hand at desired sensing distance until red light stops flashing and solenoid activates. See DETAIL C.

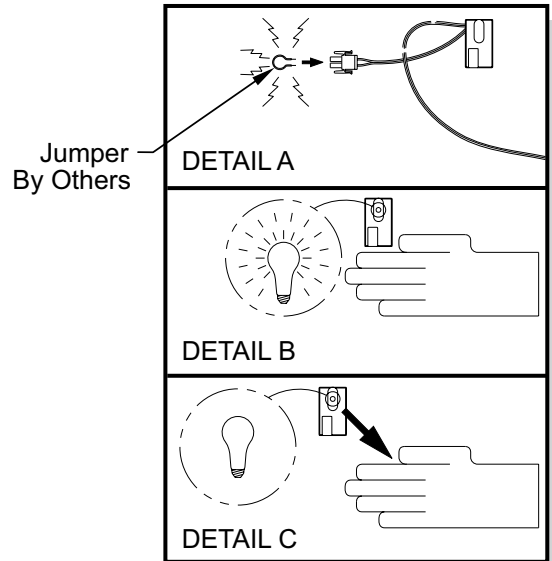

-SO Sensor Operation or -PPZ Programmable Piezo Pushbutton

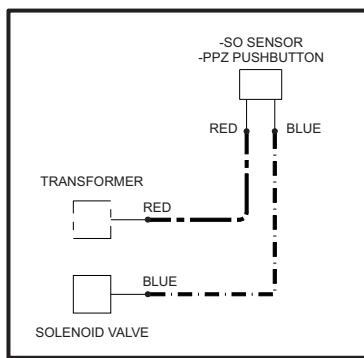
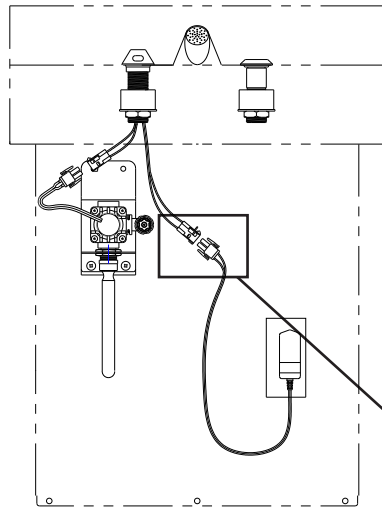

! IMPORTANT

Transformer must be plugged into a GFI protected circuit. Fixture must be earth grounded per N.E.C. or applicable codes.

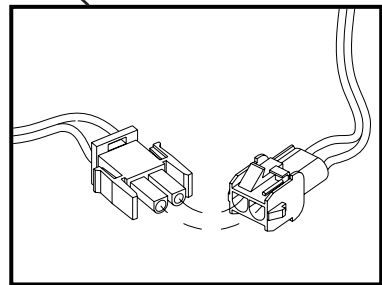



ACCESS PANEL INSTALLATION

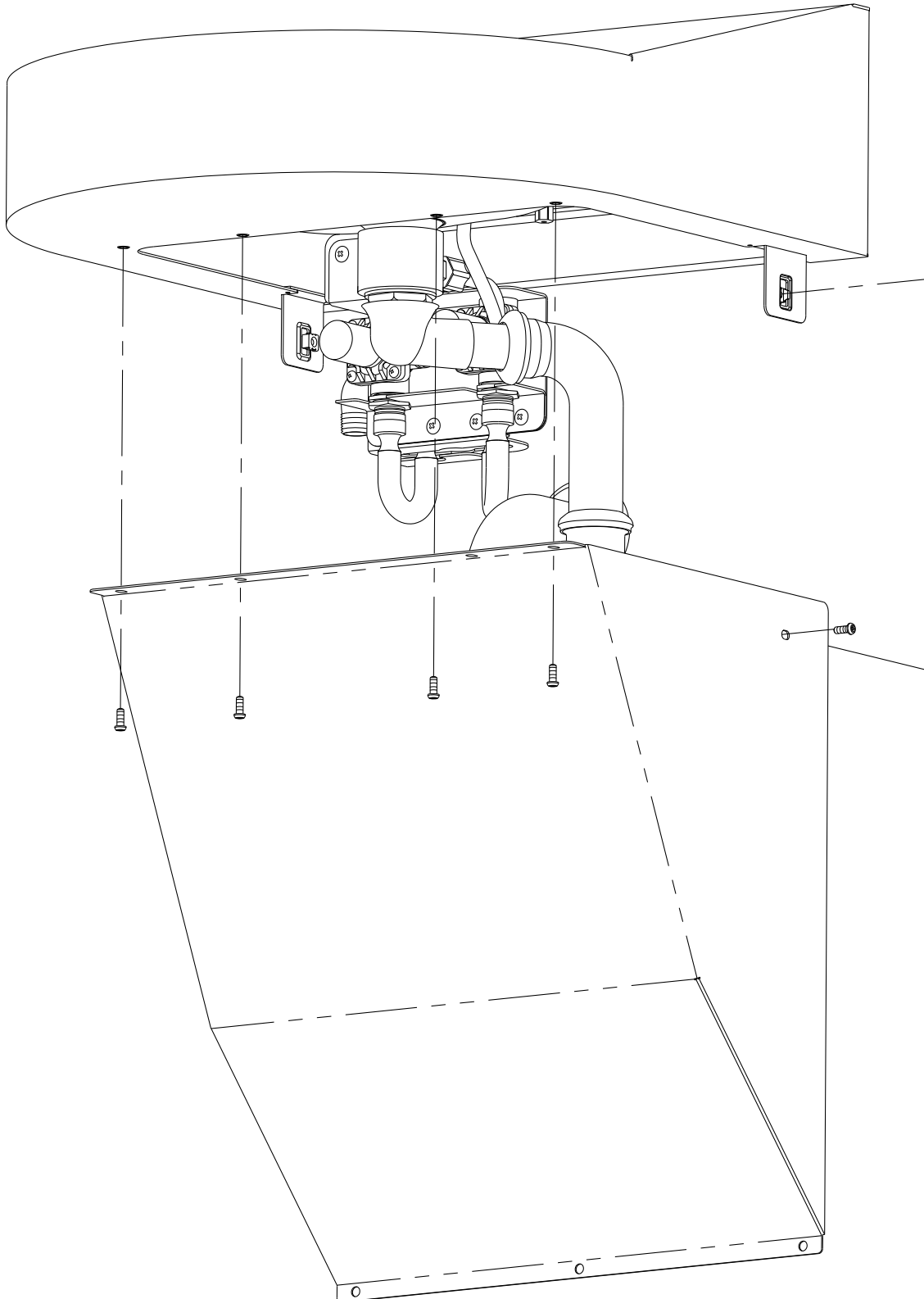

Install P-Trap cover using #10-32 x 1/2" center reject hex head screws provided. Secure bottom of P-Trap cover to wall with anchoring hardware provided by others.



TROUBLE SHOOTING FOR OPTIONAL PUSHBUTTON OPERATED VALVES

Normal Valve Function: Hand pushbutton operated valve has an adjustable flow time from 5 to 60 seconds.

CONDITION: WATER DOES NOT FLOW

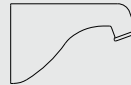

Probable Cause	Solution
Water main closed.	Open water main.
Checkstops closed.	Open checkstops.
Debris or scale in checkstop strainer	Remove checkstop strainer and clean.
Air leaks from 1/8" O.D. tubing or fittings.	Replace damaged tubing or fitting.
Pushbutton air diaphragm leaks.	Replace pushbutton air diaphragm.
Servomotor diaphragm center hole is blocked.	Remove blockage.
Servomotor upper diaphragm is damaged.	Replace servomotor upper diaphragm.
Low or no water pressure at supplies.	Increase water pressure to 30 PSI minimum.

CONDITION: WATER DRIPS, WON'T SHUT OFF

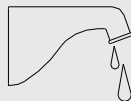

Probable Cause	Solution
Servomotor diaphragm offset hole is blocked.	Remove blockage.
Servomotor seat is damage	Replace servomotor seat.
Servomotor plate or diaphragm is obstructed.	Remove cause of obstruction.
Servomotor timer assembly is damaged.	Replace servomotor timer assembly.

CONDITION: REDUCED WATER FLOW

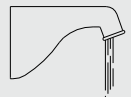

Probable Cause	Solution
Valve riser tubing is crimped.	Straighten valve riser tubing.
Debris or scale in checkstop strainer	Remove checkstop strainer and clean.
Blockage in valve flow control.	Remove blockage.
Low water pressure at supplies.	Increase water pressure to 30 PSI minimum.
Lime deposits in hot water pipes.	Remove lime deposits with appropriate cleaning solution.

CONDITION: PREMATURE WATER SHUT OFF

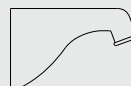

Probable Cause	Solution
Air leaks from 1/8" O.D. tubing or fittings.	Replace damaged tubing or fitting.
Pushbutton air diaphragm leaks.	Replace pushbutton air diaphragm.



CARE AND CLEANING OF STAINLESS STEEL SURFACE

NORMAL CLEANING

Clean weekly or more often, as needed (especially high polishing surfaces)

RECOMMENDED CLEANING MATERIALS

- Sponge – natural or artificial
- Nylon or other soft-bristle material brush
- Soft cloth (as used on automobile finishes)

RECOMMENDED CLEANING SOLUTIONS

- Hand dishwashing liquid/soft water solution
- Mild soap/soft water solution
- 3M Stainless Steel Cleaner/Polish
- White vinegar/soft water solution (for brightening, removing oil and hard water deposits)
- CLR Brand Cleanser or baking soda/soft water solution (for brightening, removing hard water deposits)
- Club soda and sponge

FOR HIGH POLISH STAINLESS STEEL

Note: High polish stainless steel surfaces should never come into contact with any abrasive cleaning brush, cloth or cleaning agent.

To remove smudges and fingerprints:

Wipe surfaces with a quality Stainless Steel Cleaner/Polish. Apply using a soft non-abrasive cloth, wipe surfaces with stainless steel cleaner/polish.

To remove rust stains:

Wipe surfaces with CRES (available from Acorn) or equivalent cleaner. Use recommended solutions. Apply using a soft non-abrasive sponge. Rinse surfaces immediately after application. Always follow cleaner product directions provided. Afterwards, using a soft, non-abrasive cloth, wipe surfaces with stainless steel cleaner/polish.

FOR TOUGH PROBLEMS

- CRES Cleaner specifically for rust stains (available from Acorn)
- Tarn-X for general stains
- #7 chrome polish
- Silver polish

To remove stubborn spots or to treat a scratch (Standard Satin Finish Only):

Use of synthetic, abrasive, general-purpose pads such as Scotch Brite is recommended. Apply the stainless steel cleaner/polish to the synthetic, abrasive pads and CAREFULLY rub out spot with cleaner/ polish. Be sure to rub in the direction of the grain! Do not allow steel wool to come in contact with the stainless steel. Steel particles can embed into the stainless steel surface and create rust!

Stainless steel should be kept clean at all times. If maintained, stainless steel surfaces will retain their new, clean, polished appearance indefinitely. To remove water spots or rust spots, stainless steel cleaner/polish on a cloth is recommended.

IF SPOTS ARE STUBBORN OR IF YOU WISH TO TREAT A SCRATCH: synthetic, abrasive, general-purpose pads such as Scotch Brite are recommended. Apply the stainless steel cleaner/polish to the synthetic, abrasive pad and CAREFULLY rub out spot with cleaner/polish. **Be sure to rub in the direction of the grain!** Do not allow steel wool to come in contact with stainless steel. Steel particles can embed into the stainless steel surface and create rust.



Programmable Piezo Pushbutton

Programming Instructions (Flow Time Adjustment)

The Button is factory set an 8 sec. timing cycle, if an 8 sec. cycle is adequate, then **no** programming adjustment is required. Pushing the button during the timing cycle will stop the cycle (Cycle Interrupt).

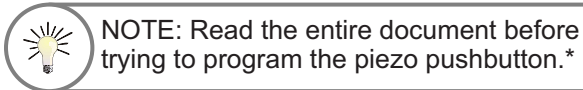

NOTE: Read the entire document before trying to program the piezo pushbutton.*

THE TIME SETTINGS PROGRAM USES 3 DIFFERENT TIMING MODES:

- **1 second timing mode:** Each push of the button adds 1 second to the total timing cycle.
- **5 second timing mode:** Each push of the button adds 5 seconds to the total timing cycle.
- **20 second timing mode:** Each push of the button adds 20 seconds to the total timing cycle.

To program the piezo pushbutton, you will need to be able to see the back of the piezo pushbutton.

Prevision must be made to access the back of the piezo pushbutton. There is an LED on the back of the piezo pushbutton under a layer of transparent epoxy, used as a programming indicator light (see page 3).



NOTE: This programming procedure moves along rapidly, there is only about 2 or 3 seconds between programming operations.

In order to start the programming the piezo pushbutton, the button must be powered down. Disconnect the red power cable and wait 20 seconds, then reconnect the red power cable.

As soon as the cable is reconnected the LED will start flashing, it will flash 4 times, then stays on for 3 seconds. During the 3 second period, push the piezo button once, the LED will go out, now you are in the **1 sec timing mode** and each time the button is pushed the LED will flash, adding 1 sec to the total timing cycle.

To move on to the **5 sec timing mode**, pause and wait for the LED to flash 2 times, now you are in the 5 sec timing mode. Each time the button is pushed the LED will flash, adding 5 sec to the total timing cycle.

To move on to the **20 sec timing mode**, pause and wait for the LED to flash 3 times, now you are in the 20 sec timing mode and each time the button is pushed the LED will flash, adding 20 sec to the total timing cycle. After programing is complete, pause and wait for the LED to flash 4 times and then 5 times, which completes the programming.

GENERAL NOTES:

- When a **timing mode is not required** then **do not** push the button and wait for the next timing mode.
- Each timing mode (1 sec, 5 sec or 20 sec timing mode) can be sequenced up to 100 times, that is the number of times, the button can be pushed, to increase the total timing cycle in each timing mode.

*See work sheet on page 2 which will simplify the programming procedure.



Programmable Piezo Pushbutton

Programming Instructions (Flow Time Adjustment)

WORKSHEET

(FILL IN ALL BOXES, WHICH WILL SIMPLIFY THE PROGRAMMING PROCEDURE)

Fill in all the Boxes below



Determine the number of seconds per timing cycle

1 Push = 1 Second

x 1 = sec



PROGRAMING STEPS:

- Power down piezo button for 20 seconds.
- Reconnect power.
- LED flashes, then stays on.
- While the LED is steady on, push button.
- LED turns off.

- You are in the 1 sec timing mode, immediately push the button, 1 push equals 1 sec added to the total timing cycle.
- Pause and wait for the LED to flash 2 times.

ADD 

1 Push = 5 Seconds

x 5 = sec



- You are in the 5 sec timing mode, immediately push the button, 1 push equals 5 sec added to the total timing cycle.
- Pause and wait for the LED to flash 3 times.

ADD 

1 Push = 20 Seconds

x 20 = sec



- You are in the 20 sec timing mode, immediately push the button, 1 push equals 20 sec added to the total timing cycle.

EQUALS 

Total timing cycle equals

 seconds

NOTE: if you miss a step in the programming procedure, just power down the button and start again from the first step.

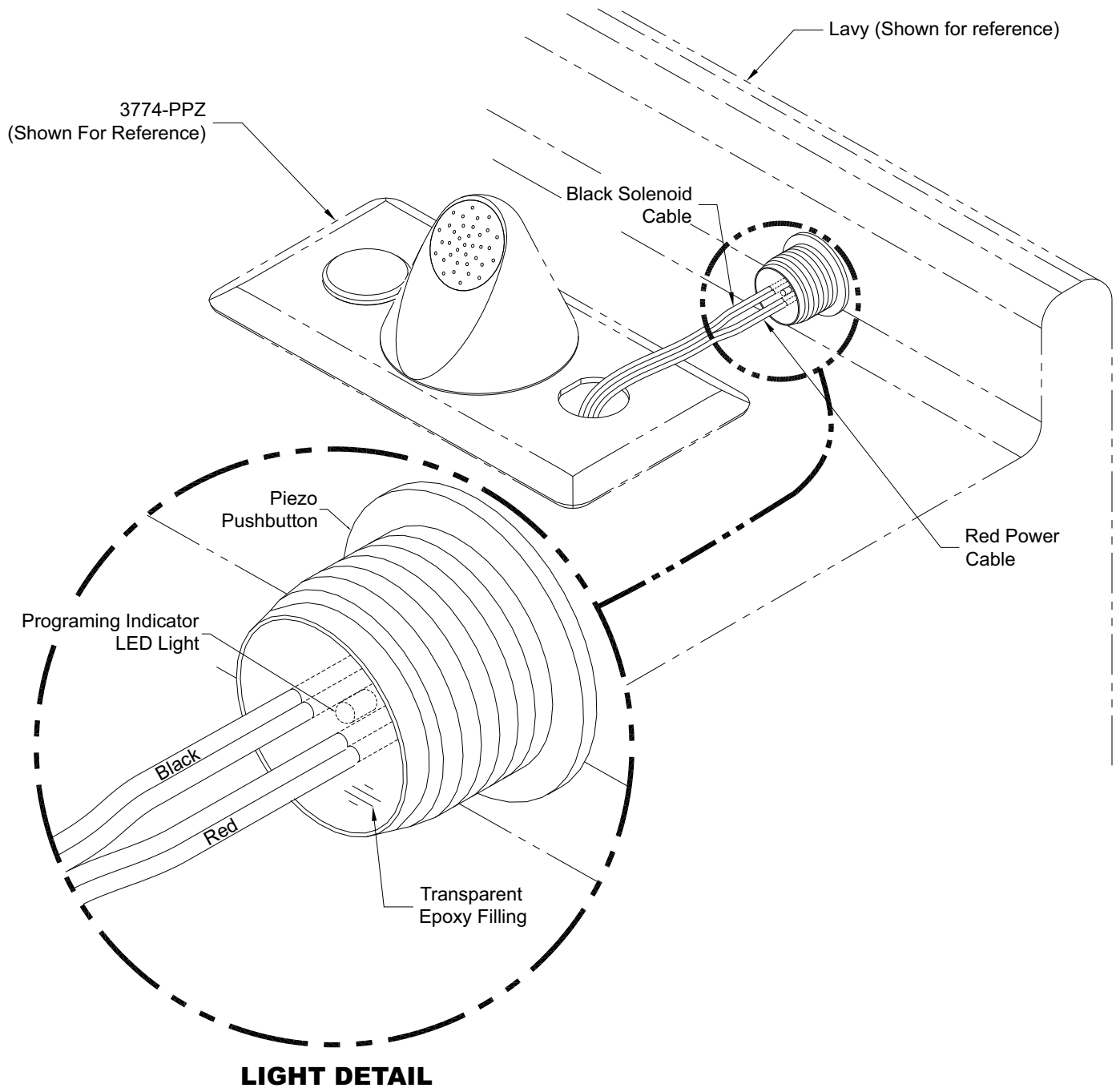



COMPONENTS & REPAIR PARTS

Description	Part No.	Diagram
HARDWARE		
#10-32 UNF x 1/2" S/S Phil Truss HD Screw	0116-010-000	
#10-32 x 1/2" S/S Hex C/R HD Screw	0112-002-000	
Allen Head Bit With Center Reject	0296-025-199	
COMBINED WASTE ASSEMBLY		
1-1/4" OD Waste Bend Connection	4970-180-001	
1-1/2" OD Tubular P-Trap	4953-001-000	
Ligature Resistant Elbow Strainer	4926-080-001	
ENCLOSURES		
P-Trap Cover	6207-331-199	
ELECTRONIC HARDWARE		
9VDC Plug-In Transformer	0710-735-001	
9 VDC Battery-Pak Assy (6 AA Batteries Not Included)	0710-358-001	
Battery-Pak Mounting Bracket	6155-013-199	

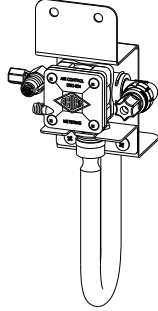
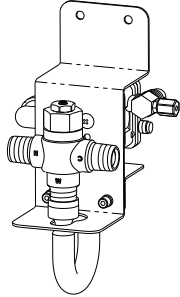
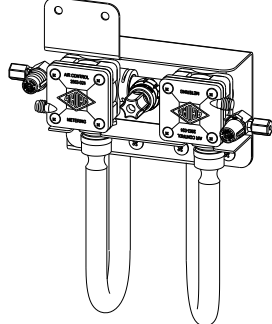
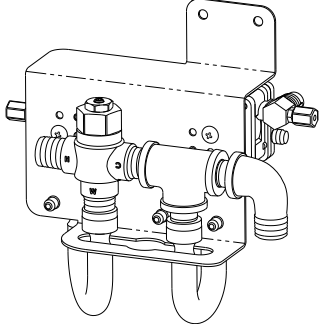

COMPONENTS & REPAIR PARTS

Description	Part No.	Diagram
VALVE		
<p>-WH3376L</p> <p>Optional -03-M Single Temp, Metering Valve Assembly</p>	2590-900-001	
<p>-WH3376L-MXTP</p> <p>Optional -03-M-MXTP, Single Temp, Temperature-Pressure Balancing Mixing Valve, ASSE 1070 Compliant</p>	2590-901-001	
<p>-WH3377L</p> <p>Optional -04-M Hot & Cold, Metering Valve Assembly</p>	2590-910-001	
<p>-WH3377L-MXTP</p> <p>Optional -04-M-MXTP, Hot & Cold, Temperature-Pressure Balancing Mixing Valve, ASSE 1070 Compliant</p>	2590-911-001	



COMPONENTS & REPAIR PARTS

Description	Part No.	Diagram
VALVE		
<p>-WH3377L-PPZ -WH3377L-WSF-SO -WH3375L-WSF-SO</p> <p>Optional Electronic Metering Valve Assembly, Single Temperature</p>	2590-905-001	
<p>-WH3377L-PPZ-MXTP -WH3377L-WSF-SO-MXTP -WH3375L-SO-MXTP</p> <p>Optional Electronic Metering Valve Assembly, Single Temp, Temperature-Pressure Balancing Mixing Valve, ASSE 1070 Compliant</p>	2590-906-001	
<p>-WH3377L-PPZ</p> <p>Optional Electronic Metering Valve Assembly, Hot and Cold</p>	2590-915-001	
<p>-WH3377L-PPZ-MXTP</p> <p>Optional Electronic Metering Valve Assembly, Hot and Cold, Temperature-Pressure Balancing Mixing Valve, ASSE 1070 Compliant</p>	2590-916-001	



Whitehall Manufacturing®
Manufacturer of Healthcare and Rehabilitation Products since 1946

Mailing Address:

P.O. Box 3527 • City of Industry, CA 91744-0527 U.S.A

Physical Address:

15125 Proctor Avenue • City of Industry, CA 91746 U.S.A

Phone 800-782-7706 • 626-968-6681

Fax 626-855-4862

Web: www.whitehallmfg.com

E-mail: info@whitehallmfg.com

MANUFACTURER'S WARRANTY

Go to www.whitehallmfg.com to fill out eWarranty Registration, keyword search: WARRANTY.

Whitehall Manufacturing Company warrants that its products are free from defects in material or workmanship under normal use and service for a period of one year from date of shipment. Whitehall's liability under this warranty shall be discharged solely by replacement or repair of defective material, provided Whitehall is notified in writing within one year from date of shipment, F.O.B. Industry, California.

This warranty does not cover installation or labor charges, and does not apply to materials which have been damaged by other causes such as mishandling or improper care or abnormal use. The repair or replacement of the defective materials shall constitute the sole remedy of the Buyer and the sole remedy of Whitehall under this warranty. Whitehall shall not be liable under any circumstances for incidental, consequential or direct charges caused by defects in the materials, or any delay in the repair or replacement thereof. This warranty is in lieu of all other warranties expressed or implied. Product maintenance instructions are issued with each fixture, and disregard or non-compliance with these instructions will constitute an abnormal use condition and void the warranty. If you have any questions or require technical assistance, please call 800-743-8219.

NOTICE TO KEEP ORIGINAL PACKAGING- Regarding warranty claims: customer must retain original packaging for one year upon receipt of product. If packaging is discarded, it is the customer's responsibility to provide adequate packaging. Any shipping claims that are a direct result of customer-provided packaging materials will be handled by the shipper.