

TEMPERATURE RATING	<p>Standard seals: -30°C to +80°C -22°F to 176°F</p> <p>High temperature seals: -20°C to +200°C* -4°F to +392°F</p> <p>Low temperature seals: -45°C to +80°C -49°F to +176°F</p>
SPEED	Gas springs are tested at 750mm/min (29.53 inch/min). Faster/Slower speeds are possible but must be tested in application.
SIDE FORCES	Should not be exposed to tilting or side forces. Use guide column and/or rotating connecting parts to eliminate transfer to gas spring.
VIBRATIONS	Certain damping characteristics can create vibrations that may resonate within the application and could cause noise. This can be reduced/eliminated by changes in installation or changing connecting parts. Rotating connecting parts or a rubber grommet* may help to isolate the gas spring from vibration.
ENVIRONMENT	Piston rod must not be painted and should be protected against shocks, scratches or dirt. Cover tubes* can be installed to protect piston rod from contact from foreign objects. Our gas springs are maintenance free. Do not oil or grease the rod or seals. Do not use cleaning products or solvents on the gas spring.
AIRBORNE PARTICULATE	Internal seals of gas springs must be protected from airborne particulates. A scraper* may be added to help reduce/eliminate ingestion of such particulates. Must be tested in application.
CHEMICALS	It is recommended to use our high-quality 316L stainless steel gas springs in food, chemical and salt water applications. Cleaning chemicals should not contact the gas spring. FDA oil* is available upon request where required.

*Non-standard components must be specified when the order is placed and may change the length of the gas spring

**Ultimately it is the customers' responsibility
to ensure the suitability of the
gas springs/product in
their own unique application.**

The theoretical extension force is calculated as follows: [Filling Pressure] x [Cross Section of the Piston Rod].
 By changing these two factors, it is possible for Bansbach® to supply gas springs with any requested extension force.
 Our standard specifications are available from 10N to 5000N. The extension force is always mentioned with the specifications and is recognized as the value F1 measured at 20°C ± 2°C with the piston rod showing downwards.

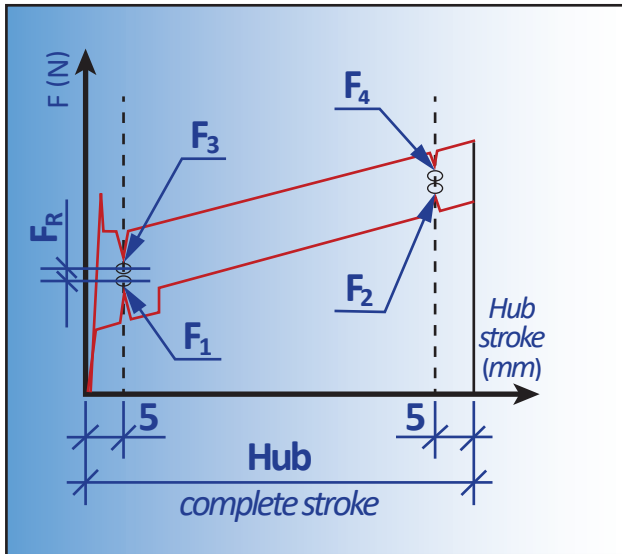

FORCE DIAGRAM

- F1** = extension force with extended piston rod
- F2** = extension force with compressed piston rod
- F3** = pull-in force with extended piston rod
- F4** = pull-in force with compressed piston rod
- FR** = friction force

These values can be influenced by factors such as gas volume and oil quality. One of the special characteristics of Bansbach® gas springs is the low friction force. Through different combinations of nozzle orifices and oil quality, it is possible to control the push-out and push-in speed as required.

CALCULATION PRINCIPLE F1

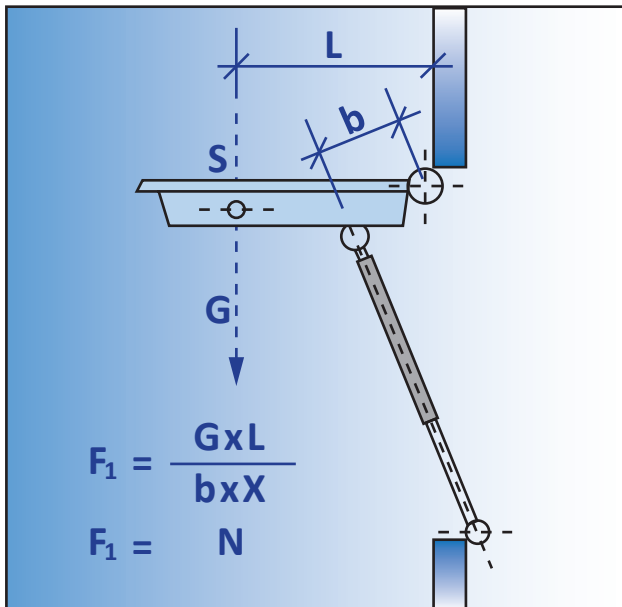

EXTENDED FORCE

- S** = Center of gravity
- G** = Weight of the flap in N (ca. Kp x 10)
- b** = Power arm
(corresponds to about 85% of the required stroke)
- X** = Number of the springs
(in general 2 pieces, one for each side of the flap)

Our general extension force tolerance is +40N/-20N or ± 5-7%
 Physically, the actual force of a gas spring depends on the temperature. For each 10°C, the force changes by approx 3.3%.
 Size and extension force can be made according to your requirements. We would be pleased to help you design a gas spring for your application.

The use of Bansbach Easylift® gas springs requires the same knowledge and attention as other technical systems having to do with force development. Though our engineers will thoroughly explain all detailed technical facts pertaining to your application, the facts mentioned below are routine for many of our regular customers.

1. Bansbach® gas springs will operate in surrounding temperatures from -30°C to +80°C. We can equip our springs with special seals to withstand temperatures as low as -55°C or as high as +200°C. For applications in low temperature surroundings, a detailed clarification of the requirements is necessary. The surrounding temperature has influence on the gas spring characteristic. Changes of the extension force as well as of the damping characteristics have to be considered and should be tested in advance within the application. Gas springs should not be overheated or put in open fire! Other environmental conditions can also influence the considerable life time of gas springs. Please take appropriate, preventative measures into consideration.
2. Gas springs are filled with pure nitrogen. Nitrogen is an inert gas, which does not burn, will not explode and is not poisonous. However, gas springs have very high internal pressure (up to approx. 300 bar). Do not open without instruction!
3. Disposal/Recycling: Gas springs consist of mostly metal and can be recycled, but first the gas must be depressurized.
4. All Bansbach® gas springs are labeled with the warning, "Do Not Open – High Pressure", the part number, and the production date. If these dates are illegible (i.e. removed, painted over or otherwise influenced) we refuse the liability for damages. If any of this information is unreadable, the warranty will be void.
5. Bansbach® gas springs can be used generally as a limit stop in both directions. The occurring forces should not exceed the following approximate values. In case of reaching the limit range or a permanent use as limit stop, please contact Bansbach Easylift®.

SERIES	MAX FORCE (N)	SERIES	MAX FORCE (N)	SERIES	MAX FORCE (N)
3-8	600	8-20 Alu	3,500	12-28	9,250
3-10	600	8-22	5,000	12-40	12,500
4-12	1,500	8-28	7,000	14-28	7,000
6-15	2,500	10-22	5,500	14-28 Stainless	6,250
6-15 Stainless	1,750	10-22 Stainless	3,000	14-40	15,000
6-19	2,000	10-28	8,500	16-28	10,000
8-19	5,000	10-28 Stainless	6,500	20-40 Stainless	15,000
8-19 Stainless	3,000	10-40	7,000	20-40	20,000

This isn't valid for lockable gas springs or traction springs!

Attention: The figures refer to the average pressure range of the respective size. Some connectors such as elbow joints may not be suitable for the above values.

6. Gas springs should be installed with the piston rod downwards. This position ensures the best damping effect. Only Bansbach® gas springs include an integrated grease chamber which allows different directions of installation.
7. Gas springs should not be exposed to any tilting or side forces during operation. If this is unavoidable, please check the installation and use suitable connecting parts.
8. If gas springs are visibly damaged (i.e. broken or deformed connecting parts, bent piston rod, dented cylinder, etc.) due to external causes (accident, collision, extreme overloading, etc.) the pressure of the gas spring MUST be released before the spring is dismantled or used. Please note our disposal and recycling instructions.
9. Gas springs are maintenance-free. Do not grease or oil the piston rod.
10. The piston rod must not be painted and should be protected against shocks, scratches and dirt. The cylinder should not be deformed. Such damage will destroy the sealing system.
11. Bansbach® gas springs can be stored in any position. Pressure loss through long storage is not to be expected. There are no negative values known, but there may be a sticking effect the first time you compress a spring, which may require a higher expenditure of force the first time (initial breakaway force).
12. Warranty claims expire 1 year from date of production. Manufacturing mistakes and/or quality defects are immediately noticeable. If you are unhappy for any reason with the delivered quality, we ask you notify Bansbach immediately. A detailed description of the defect will be necessary to receive approval for returning any part.
13. If gas springs are sent to us for a detailed examination, the agreement for the demolition of this part is given and the property right expires. A return delivery of single components is not possible. If applicable please assign the delivery with e.g. "For functional testing and requesting you to send the parts back." If there is no objective available, the delivered gas springs will be disposed 1 week after the announcement of the test result. For unjustified claims, we reserve the right to charge a lump-sum or the actual costs incurred for handling and disposal.
14. Bansbach® gas springs, which mostly consist of parts held in stock, are produced according to customer orders. A cancellation, post-production modification, order change or refusal is therefore not possible.
15. Bansbach® gas springs are built and tested for highest requirements and highest reliability. Installation advices as well as our comprehensive advices will help you in choosing your gas springs.
NOTE: The examination and suitability for the respective application must be executed by the customer/installers. Do not use the gas springs in applications that are not suitable or in faulty products. We cannot assume any liability for the function and the lifetime of your final product.
16. Damping characteristics can create vibrations which lead to a resonator within the application and may cause noise. Little changes concerning the installation or attachments may help to avoid them.
17. You can select your best dimensions yourself, within the mentioned limits. The tolerance for the lengths is generally deemed to be ±2.5mm; in series production, there is a tolerance of max. ±1mm. If very high demands are placed on durability and stability, please avoid the combination of small diameter + long stroke + high force.