

Above: PS016-0212 (Quartz ABS Plastic) shown with Sign Holder, MP-047 (sold separately)
Below: Using Lower right glove area as a shelf for supplies



Product Description:

- Protection System
- Holds a variety of gowns, three boxes of gloves, one box of earloop-style face masks, one box of shield-style face masks, and built-in storage area (for a variety of medical supplies, fourth box of gloves, or one box of N-95 face masks)
- Keyholes for wall mounting or may be used with a BOWMAN® door or wall hanger
- Made of Clear PETG plastic

Primary Area for Product Usage:

- All patient care areas requiring personal protective equipment and isolation supplies, including oncology clinics, dialysis centers and clinic exam areas

Dispenses:

- Top left section: Gowns folded up to 14.9"W x 4.5"D
- Top right section: One box of shield-style face masks up to 8.1"W x 9.9"H x 4.5"D
- Middle right section: One box of earloop-style face masks up to 8.0"W x 5.3"H x 4.5"D
- Four bottom sections: Four glove boxes up to 11.5"W x 5.5"H x 4.5"D, or three glove boxes and miscellaneous medical supplies in bottom right

Accessories (sold separately):

- Sign Holder MP-047
- BOWMAN® door and wall hangers: MB-450, MB-500, MB-510, and MB-600
- Clip-On Caddy Dispensers: MP-015 and MP-085

Package Specifications:

- 26"L x 6"W x 32"H (66.0 cm x 15.2 cm x 81.3 cm)
- 12 lbs (5.4 kg) - approximated

Product Specifications (overall external dimensions):

- 23.38"W x 26.63"H x 4.75"D (59.4 cm x 67.6 cm x 12.1 cm)
- 3.10 lbs (1.4 kg) - approximated

Mounting Specifications:

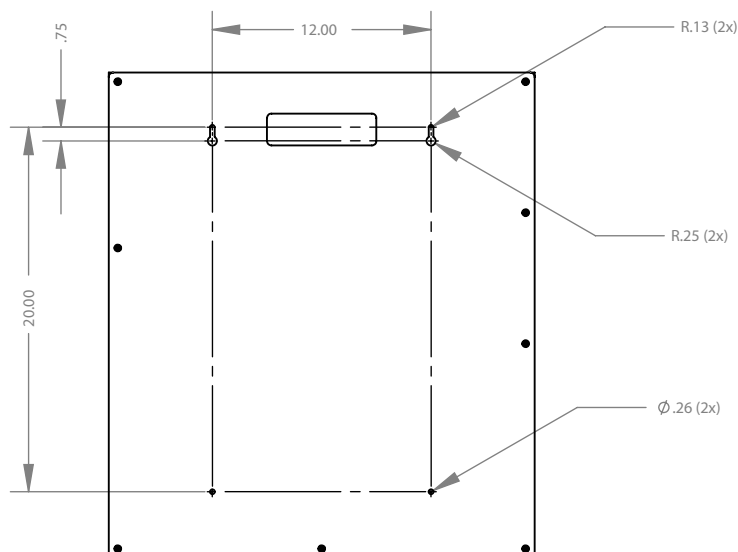

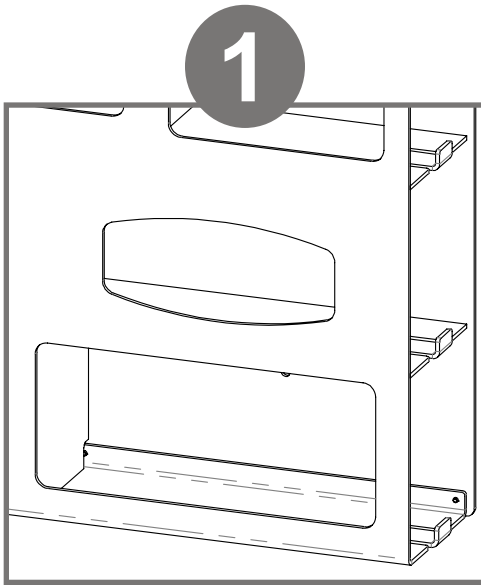

Open section at lower right can be used to store a variety of boxed or loose medical supplies.

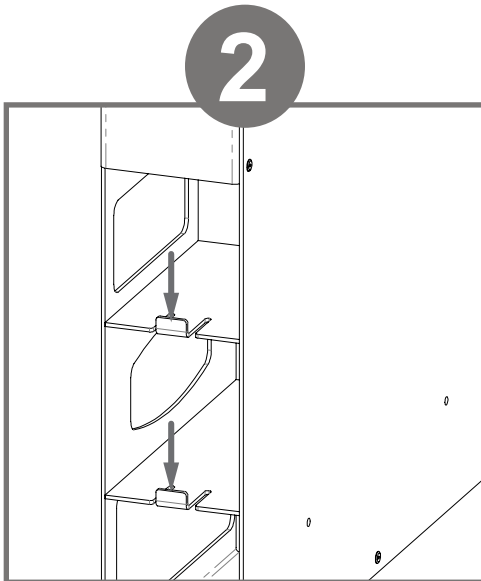
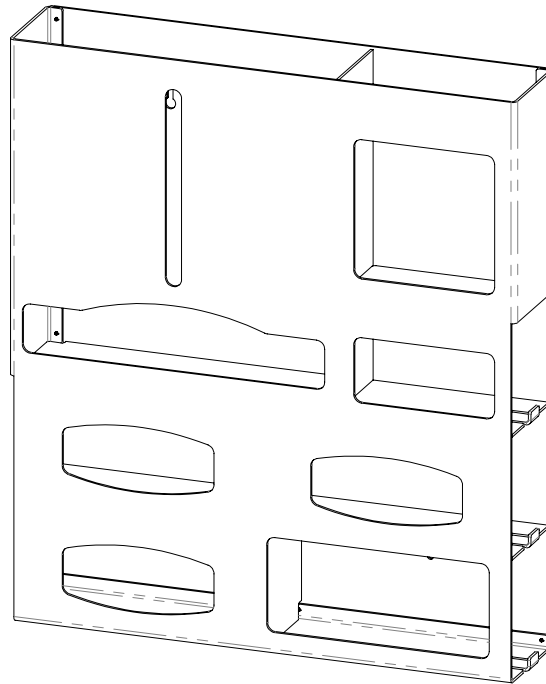

The flexible tabs on the side are designed to hold product securely in the dispenser. To add or remove product, press down on the tab and pull box out.

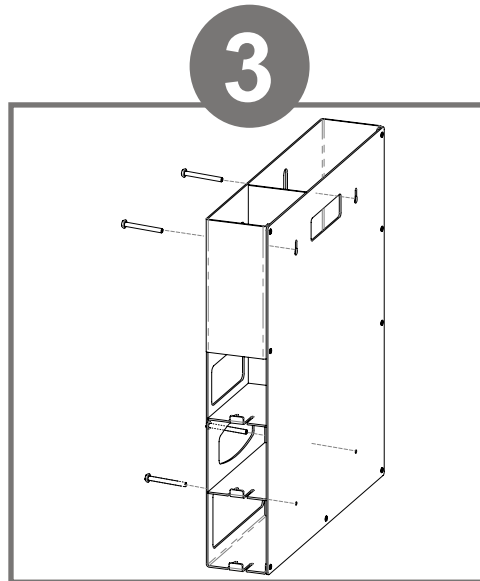

Dispenser should be mounted securely to a wall through keyholes in back with screws approved and provided by building maintenance.

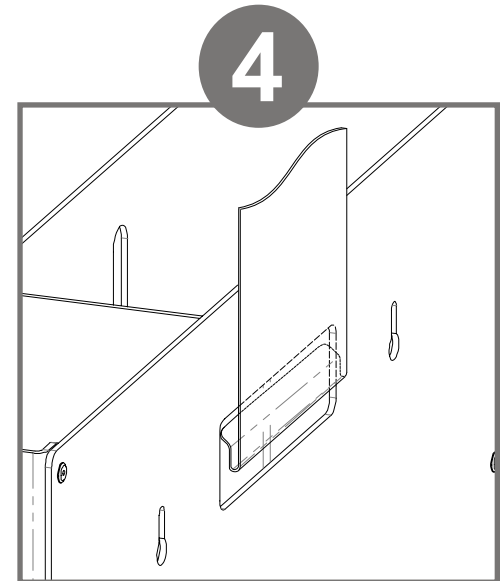

Alternatively, dispenser can be attached to a surface by hanging on a BOWMAN® door or wall hanger (sold separately) through the cut-out on the back of the dispenser.

Parts included:

- Protection system

Tools required:

- No tools required to assemble system



Advantage

Designed for Long-Term Heavy-Duty Applications

Copolyester resin is designed for heavy-duty applications, and is used by Bowman® Dispensers exclusively.

Major Benefits

Toughness

Copolyester (PETG) is typically 15-20 times tougher than general purpose acrylic. PETG is made to withstand handling and reduce losses due to breakage.

Chemical Resistance

PETG resists a variety of chemicals and commonly used cleaning agents.

Impact Strength

PETG is tough and durable (not brittle), providing years of trouble-free functionality and long life.

Clarity and Gloss

PETG looks good and makes an attractive display. Clear optical characteristics mean the viewer can see the content, read text, and see true colors through the material. Complies with FDA regulations for food contact.

Easy to Clean

Most cleaning chemicals do not weaken the surface or cause damage to the material. Suggested cleaning method is to use a soft cloth, warm water, and mild soap.

