



## Vestil Manufacturing Corp.

2999 North Wayne Street, P.O. Box 507, Angola, IN 46703

Telephone: (260) 665-7586 -or- Toll Free (800) 348-0868

Fax: (260) 665-1339

Web: [www.vestilmfg.com](http://www.vestilmfg.com) e-mail: [info@vestil.com](mailto:info@vestil.com)

### LMS-Series Fork Truck Attachments



**LMS-EBT**



**LMS-EBNT**

#### Receiving Instructions

After delivery, remove the packaging from the product. Inspect the product closely to determine whether it sustained damage during transport. If damage is discovered, record a complete description of it on the bill of lading. If the product is undamaged, discard the packaging.

**NOTE:** The end-user is solely responsible for confirming that product design, use, and maintenance comply with laws, regulations, codes, and mandatory standards applied where the product is used.

#### Technical Service & Replacement Parts

For answers to questions not addressed in these instructions and to order replacement parts, labels, and accessories, call our Technical Service and Parts Department at (260) 665-7586. The department can also be contacted online at [http://www.vestilmfg.com/parts\\_info.htm](http://www.vestilmfg.com/parts_info.htm).

#### Electronic copies of Instruction Manuals

Additional copies of this instruction manual may be downloaded from <https://www.vestil.com/page-manuals.php>





#### Table of Contents

#### Page

Signal Words.....	2
Safety Instructions.....	2
National Standards.....	2
FIG. 1A; FIG. 1B; FIG. 1C (LMS-EBT Exploded Views) & Bills of Materials.....	3
FIG. 1D & FIG. 1E (LMS-EBT) Centers of Gravity And Max. Load Ratings.....	4
FIG. 2A; FIG. 2B; FIG. 2C (LMS-EBNT Exploded Views) & Bills of Materials.....	5
FIG. 2D & FIG. 2E (LMS-EBNT) Centers of Gravity And Max. Load Ratings.....	6
Loading & Using the Boom.....	7, 8
Record of Satisfactory Condition.....	9
Load Tests.....	9
Inspections.....	10
Maintenance.....	10
Labeling Diagram.....	11
Limited Warranty.....	12

## SIGNAL WORDS

SIGNAL WORDS in this manual draw the reader's attention to important safety-related messages.

	<b>Identifies a hazardous situation which, if not avoided, WILL result in DEATH or SERIOUS INJURY. Use of this signal word is limited to the most extreme situations.</b>
	<b>Identifies a hazardous situation which, if not avoided, COULD result in DEATH or SERIOUS INJURY.</b>
	<b>Indicates a hazardous situation which, if not avoided, COULD result in MINOR or MODERATE injury.</b>
	<b>Identifies practices likely to result in product/property damage, such as operation that might damage the product.</b>

## SAFETY INSTRUCTIONS

Vestil strives to identify foreseeable hazards associated with the use of its products. However, material handling is dangerous and no manual can address every conceivable risk. The end-user ultimately is responsible for exercising sound judgment at all times. Acquire a copy of the latest version of ANSI B56.1, which is freely downloadable on [www.ITSDF.org](http://www.ITSDF.org). Apply all relevant portions of Part II "For the User". The following recommendations are intended to complement the guidance provided in B56.1.

### WARNING

Material handling is dangerous. Improper or careless operation might result in serious personal injuries.

- Always use this boom in compliance with all rules applied to fork truck attachments at your worksite.
- DO NOT use a damaged boom. Only use the boom if it is in **SATISFACTORY CONDITION** (p. 9). Inspect the boom before each use according to the relevant **INSPECTION** instructions on p. 10.
- DO NOT *contact* electrified wires with the boom, load, or lift truck.
- DO NOT use the boom if the safety chain is damaged or missing. The only function of the safety chain is to prevent the boom from sliding off of the forks. DO NOT use the safety chain to lift loads. It is NOT intended or designed to bear the full load rating of the boom.
- DO NOT lift the boom until it is securely connected to the carriage of the fork truck with the restraint strap.
- DO NOT attempt to lift a load weighing more than the boom's maximum rated load. Load ratings for all boom variants appear on pages 4 and 6.
- NEVER lift this boom, or loads connected to the boom, over people.
- DO NOT permit any person to stand beneath, or travel under, the boom or the load.
- Inform everyone in the area to stay clear of the boom and the supported load during use.
- DO NOT allow people to ride on either the boom or the load.
- DO NOT use the boom if any label is damaged, missing, or not easily readable from a reasonable, safe distance. Contact **TECHNICAL SERVICE** to order replacement labels. See **LABELING DIAGRAM** on p. 12.
- ALWAYS apply proper (fork) lift operation practices learned during your training program.
- Always make sure that shackle pins (see shackles in exploded views on pages 3 & 5) are secure before applying a load to the load hook. Tighten the screw pin before each use.
- Before raising the boom from the floor AND before attaching the load to the boom, tilt the fork lift mast away from the boom to ensure that the boom will not slide towards the tips of the forks.
- ALWAYS follow the **LOADING AND USING** instructions that appear on p. 7-8. Failure to properly position a load might cause a dangerous degree of load swing when the boom is elevated.
- Only use the boom to lift loads. DO NOT use the boom to drag items.
- Transport loads with the load as low as possible.
- Drive, brake, and turn slowly with suspended loads to avoid causing the load to swing.
- DO NOT modify the boom in any way. Modifications automatically void the **LIMITED WARRANTY** (p. 12) and might make the boom unsafe to use.

## NATIONAL STANDARDS

US OSHA Rule 1910.178 (29 CFR 1910.178; the "Rule") classifies this device as a (lift truck) front end attachment whenever it is mounted on a lift truck. The Rule incorporates American National Standard ANSI/ITSDF B56.1 (the "Standard"). The Standard is published by the Industrial Truck Standards Development Foundation on its website ([www.itsdf.org](http://www.itsdf.org)) where it is freely downloadable at <http://www.itsdf.org/cue/b56-standards.html>. Before putting this device into service, you must acquire a copy of the Standard. Apply all relevant parts of Part II: For the User. If instructions provided in this manual conflict with the Standard, then you should apply the instructions in the Standard. Vestil requests that you immediately share any such conflicts with its **TECHNICAL SERVICE** personnel. Contact information for **TECHNICAL SERVICE** appears on the cover page of this manual.

**FIG. 1A:** LMS-EBT-46-4 Exploded View & Bill of Materials (08-006-210)

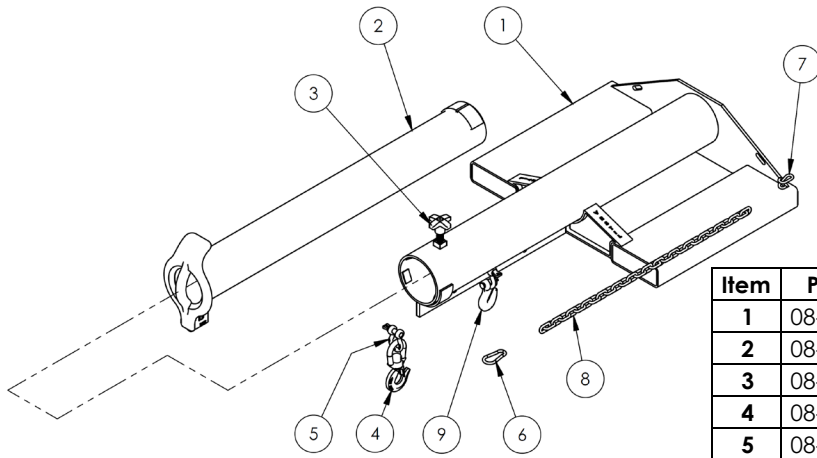

Item	Part no.	Description	Quantity
1	08-514-268	Weldment, frame, boom/base	1
2	08-514-278	Weldment, inner tube, shorty	1
3	08-025-004	X-handle, locking bolt	1
4	08-145-001	Swivel hook, 2-ton	1
5	08-145-010	1/2" 2-ton shackle	1
6	08-145-041	5/16" snap hook	1
7	99-145-084	Lap link	1
8	99-145-037	5/16" chain 36" long	1
9	99-645-019	2-ton hook and shackle	1

**FIG. 1B:** LMS-EBT-46-6 Exploded View & Bill of Materials (08-006-211)

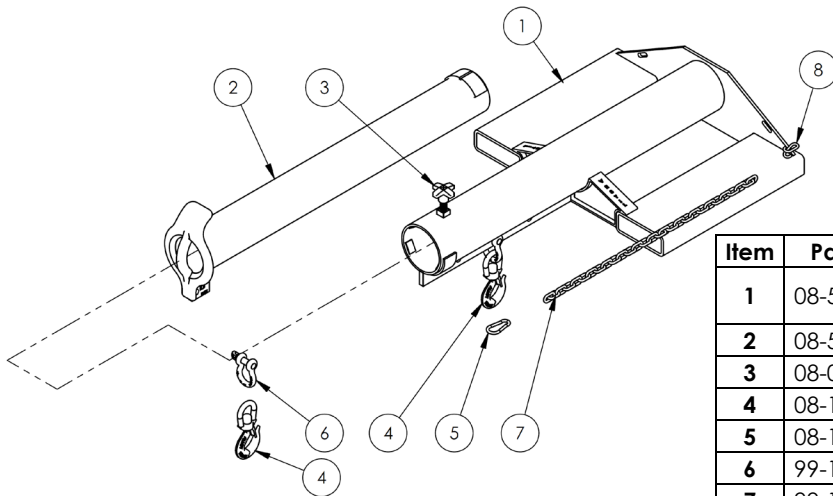

Item	Part no.	Description	Quantity
1	08-514-270	Weldment, frame, boom/base	1
2	08-514-266	Weldment, inner tube, shorty	1
3	08-025-004	X-handle, locking bolt	1
4	08-145-002	Swivel hook, 3-ton	2
5	08-145-041	5/16" snap hook	1
6	99-145-019	3 1/4-ton shackle, 5/8"	2
7	99-145-037	5/16" chain 36" long	1
8	99-145-084	Lap link	1

**FIG. 1C:** LMS-EBT-46-8 Exploded View & Bill of Materials (08-006-212)

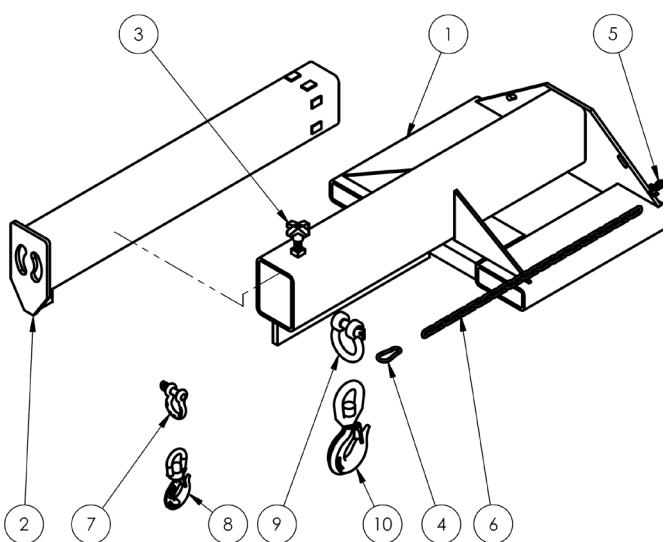

Item	Part no.	Description	Quantity
1	08-514-277	Weldment, frame, boom/base	1
2	08-514-275	Weldment, inner tube, shorty	1
3	08-025-004	X-handle, locking bolt	1
4	08-145-041	5/16" snap hook	1
5	99-145-084	Lap link	1
6	99-145-037	5/16" chain 36" long	1
7	99-145-019	5/8" 3 1/4-ton shackle	1
8	08-145-002	Swivel hook, 3-ton	1
9	08-145-006	7/8" 6 1/2-ton shackle	1
10	08-145-005	Swivel hook, 5-ton	1

**FIG. 1D:** LMS-EBT-4k, 6k & 8k Centers of Gravity and Maximum Load Ratings for Varying Load Attachment Points

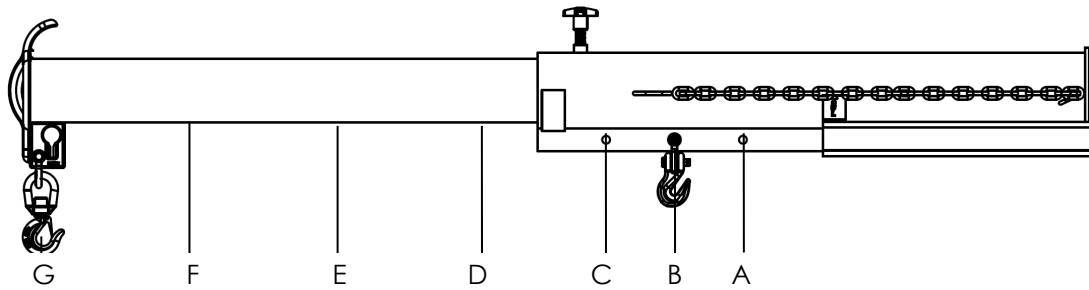

Hook position	A	B	C	D	E	F	G
Distance from end of boom	31" 79 cm	37" 94 cm	43" 109 cm	52 <sup>3</sup> / <sub>4</sub> " 134 cm	66" 168 cm	79 <sup>1</sup> / <sub>4</sub> " 201 cm	92 <sup>3</sup> / <sub>4</sub> " 236 cm
<b>Maximum rated load of a load suspended from a single hook located at the corresponding "Hook position".</b>							
<b>LMS-EBT-46-4</b>	4000 lb. 1820 kg	3880 lb. 1763 kg	3760 lb. 1709 kg	3560 lb. 1618 kg	3290 lb. 1495 kg	3020 lb. 1372 kg	2750 lb. 1250 kg
<b>LMS-EBT-46-6</b>	6000 lb. 2727 kg	5710 lb. 2595 kg	5420 lb. 2463 kg	4945 lb. 2247 kg	4300 lb. 1954 kg	3650 lb. 1659 kg	3000 lb. 1364 kg
Distance from end of boom	31" 79 cm	37" 94 cm	43" 109 cm	52" 134 cm	64" 168 cm	76 <sup>1</sup> / <sub>2</sub> " 201 cm	89" 236 cm
<b>LMS-EBT-46-8</b>	8000 lb. 3636 kg	7600 lb. 3454 kg	7200 lb. 3272 kg	6610 lb. 3004 kg	5825 lb. 2647 kg	5010 lb. 2277 kg	4200 lb. 1909 kg

The center of gravity of the boom changes as boom length changes. As shown in the diagram below, the horizontal center of gravity may be located at any point from RHCG to EHCG:

- Retracted horizontal center of gravity (RHCG): boom fully *retracted* and unloaded. RHCG is measured from the "origin point" of the above diagram (edges of the fork pockets);
- Extended horizontal center of gravity (EHCG): boom fully *extended* and unloaded. EHCG is also measured from the "origin point" of the above diagram (edges of the fork pockets);
- All other combinations of boom extension and load position produce a horizontal center of gravity located somewhere between RHCG and EHCG.

**FIG. 1E:** LMS-EBT-46 centers of gravity and dimensions

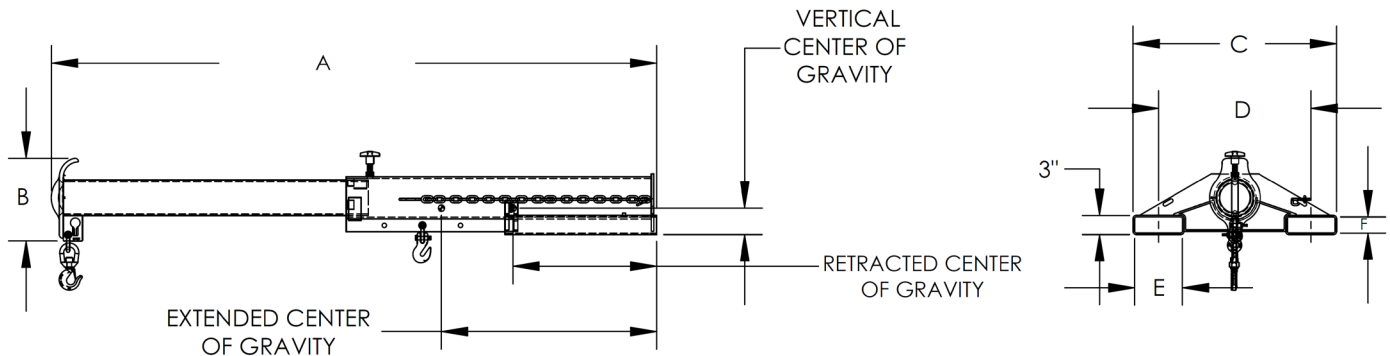

Model	Extended horizontal center of gravity	Retracted horizontal center of gravity	Vertical center of gravity	A	B	C	D	E	F	Net weight
LMS-EBT-46-4	33 <sup>5</sup> / <sub>16</sub> " (84.6 cm)	22 <sup>15</sup> / <sub>16</sub> " (58.3 cm)	4 <sup>1</sup> / <sub>8</sub> " (10.5 cm)	55 <sup>1</sup> / <sub>4</sub> -95 <sup>1</sup> / <sub>4</sub> "	13"	32"	24"	7 <sup>1</sup> / <sub>2</sub> "	2 <sup>1</sup> / <sub>2</sub> "	267.2 lb.
LMS-EBT-46-6	31 <sup>5</sup> / <sub>16</sub> " (79.5 cm)	22 <sup>1</sup> / <sub>16</sub> " (56 cm)	3 <sup>3</sup> / <sub>4</sub> " (9.5 cm)	55 <sup>1</sup> / <sub>4</sub> -95 <sup>1</sup> / <sub>4</sub> "	13"	32"	24"	7 <sup>1</sup> / <sub>4</sub> "	2 <sup>1</sup> / <sub>4</sub> "	302.5 lb.
LMS-EBT-46-8	34 <sup>1</sup> / <sub>16</sub> " (86.5 cm)	22 <sup>3</sup> / <sub>4</sub> " (57.8 cm)	4 <sup>3</sup> / <sub>8</sub> " (11.1 cm)	53 <sup>7</sup> / <sub>8</sub> -90 <sup>7</sup> / <sub>8</sub> "	11 <sup>1</sup> / <sub>2</sub> "	32"	24"	7 <sup>1</sup> / <sub>4</sub> "	2 <sup>1</sup> / <sub>4</sub> "	442.3 lb.

**FIG. 2A:** LMS-EBNT-40-4 Exploded View & Bill of Materials (08-006-213)

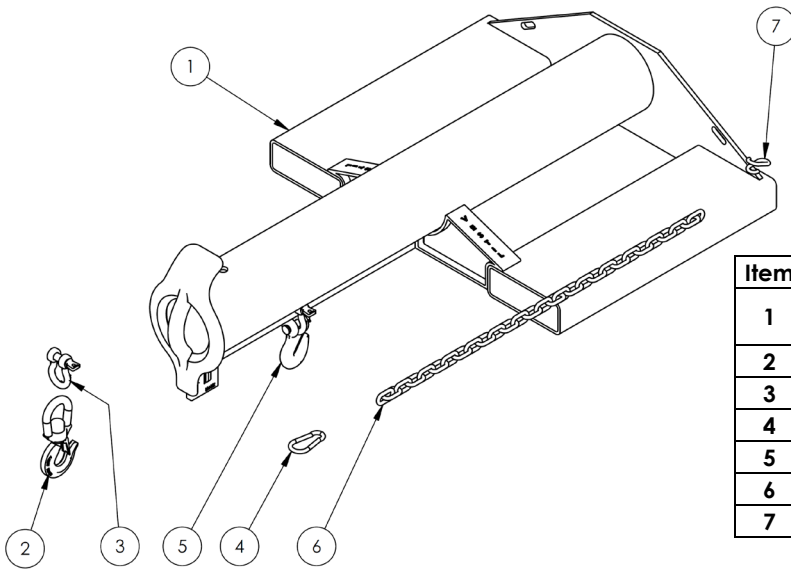

Item	Part no.	Description	Quantity
1	08-514-196	Weldment, frame, boom/base	1
2	08-145-001	Swivel hook, 2-ton	1
3	08-145-010	1/2" 2-ton shackle	1
4	08-145-041	5/16" snap hook	1
5	99-645-019	2-ton hook and shackle	1
6	99-145-037	5/16" chain 36" long	1
7	99-145-084	Lap link	1

**FIG. 2B:** LMS-EBNT-40-6 Exploded View & Bill of Materials (08-006-214)

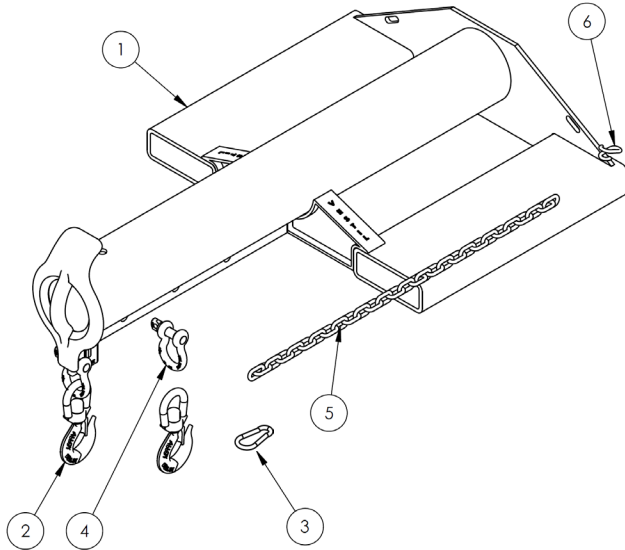

Item	Part no.	Description	Quantity
1	08-514-197	Weldment, frame, boom/base	1
2	08-145-002	Swivel hook, 3-ton	1
3	08-145-041	5/16" snap hook	1
4	99-145-019	3 1/4-ton shackle, 5/8"	2
5	99-145-037	5/16" chain 36" long	1
6	99-145-084	Lap link	1
7	08-145-001	Swivel hook, 2-ton	1
8	08-145-010	1/2" 2-ton shackle	2

**FIG. 2C:** LMS-EBNT-40-8 Exploded View & Bill of Materials (08-006-215)

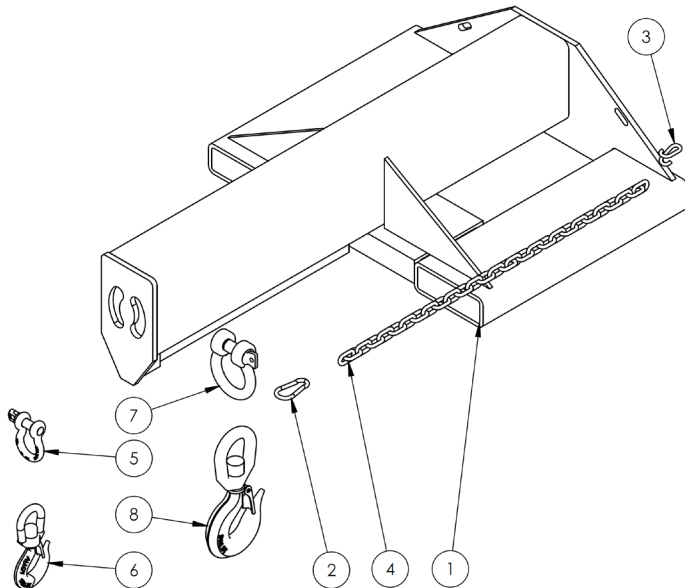

Item	Part no.	Description	Quantity
1	08-514-203	Weldment, frame, boom/base	1
2	08-145-041	5/16" snap hook	1
3	99-145-084	Lap link	1
4	99-145-037	5/16" chain 36" long	1
5	99-645-019	5/8" 3 1/4-ton hook and shackle	1
6	08-145-002	Swivel hook, 3-ton	1
7	08-145-006	7/8" 6 1/2-ton shackle	1
8	08-145-005	Swivel hook, 5-ton	1

**FIG. 2D:** LMS-EBNT-40-4k, 6k & 8k Centers of Gravity and Maximum Load Ratings for Varying Load Attachment Points

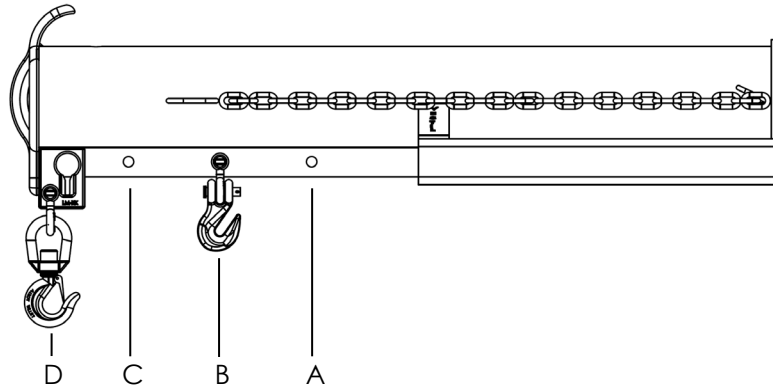

Hook position	A	B	C	D
Distance from end of boom	31" 79 cm	37" 94 cm	43" 109 cm	48 <sup>1</sup> / <sub>8</sub> " 122 cm
<b>Maximum rated load of a load suspended from a single hook located at the corresponding "Hook position".</b>				
<b>LMS-EBNT-40-4</b>	4000 lb. 1820 kg	3915 lb. 1779 kg	3830 lb. 1740 kg	3750 lb. 1705 kg
<b>LMS-EBNT-40-6</b>	6000 lb. 2727 kg	5650 lb. 2568 kg	5300 lb. 2409 kg	5000 lb. (2045 kg)
Distance from end of boom	31" 79 cm	37" 94 cm	43" 109 cm	47 <sup>1</sup> / <sub>2</sub> " 122 cm
<b>LMS-EBNT-40-8</b>	8000 lb. 3636 kg	7275 lb. 3306 kg	6550 lb. 2977 kg	6000 lb. 3023 kg

Center of gravity has both a horizontal component and a vertical component. The *vertical* center of gravity (VCG) lies along a line parallel to the bottom edges of the fork pockets. Similarly, the *horizontal* center of gravity (HCG) lies along a vertical line from the outer edges of the fork pockets.

**FIG. 2E:** LMS-EBNT centers of gravity and dimensions

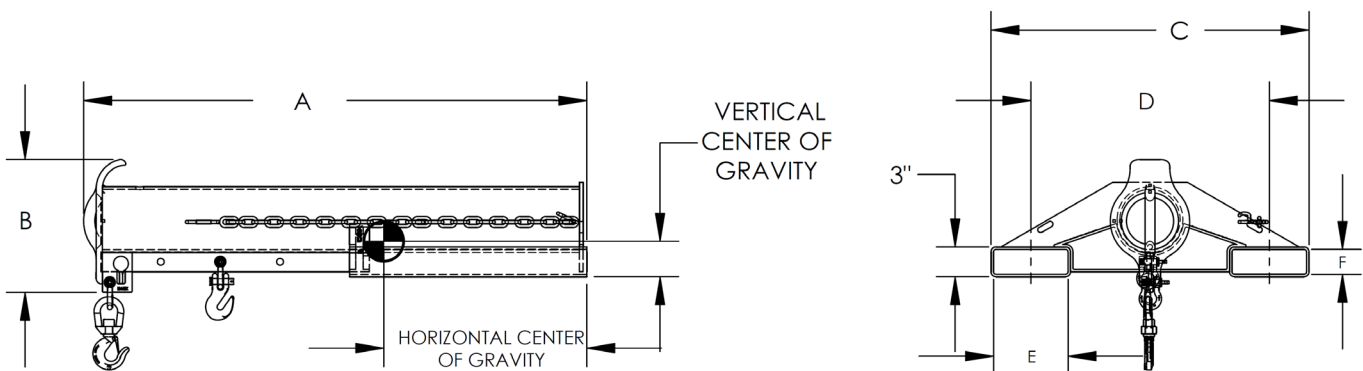

Model	Horizontal center of gravity	Vertical center of gravity	A	B	C	D	E	F	Net weight
LMS-EBNT-40-4	20 <sup>7</sup> / <sub>16</sub> " (20.4 cm)	3 <sup>9</sup> / <sub>16</sub> " (9.0 cm)	50 <sup>3</sup> / <sub>4</sub> "	13 <sup>5</sup> / <sub>16</sub> "	32"	24"	7 <sup>1</sup> / <sub>2</sub> "	2 <sup>1</sup> / <sub>2</sub> "	204 lb.
LMS-EBNT-40-6	19 <sup>1</sup> / <sub>2</sub> " (49.5 cm)	3 <sup>1</sup> / <sub>4</sub> " (8.3 cm)	50 <sup>5</sup> / <sub>8</sub> "	13 <sup>5</sup> / <sub>16</sub> "	32"	24"	7 <sup>1</sup> / <sub>4</sub> "	2 <sup>1</sup> / <sub>4</sub> "	239 lb.
LMS-EBNT-40-8	20 <sup>5</sup> / <sub>8</sub> " (52.4 cm)	3 <sup>5</sup> / <sub>8</sub> " (9.2 cm)	49 <sup>3</sup> / <sub>8</sub> "	11 <sup>1</sup> / <sub>2</sub> "	32"	24"	7 <sup>1</sup> / <sub>4</sub> "	2 <sup>1</sup> / <sub>4</sub> "	329 lb.

# LOADING AND USING THE BOOM

Periodically review the [SAFETY INSTRUCTIONS](#) on p. 2.

1. Drive the forklift forward and insert the tines into the fork pockets. Drive as far forward as possible. Lower the forks completely. The drawings below demonstrate this step:

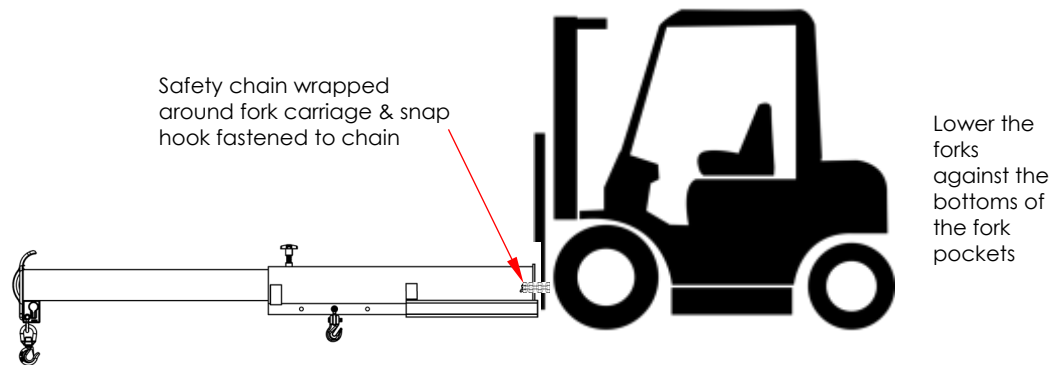
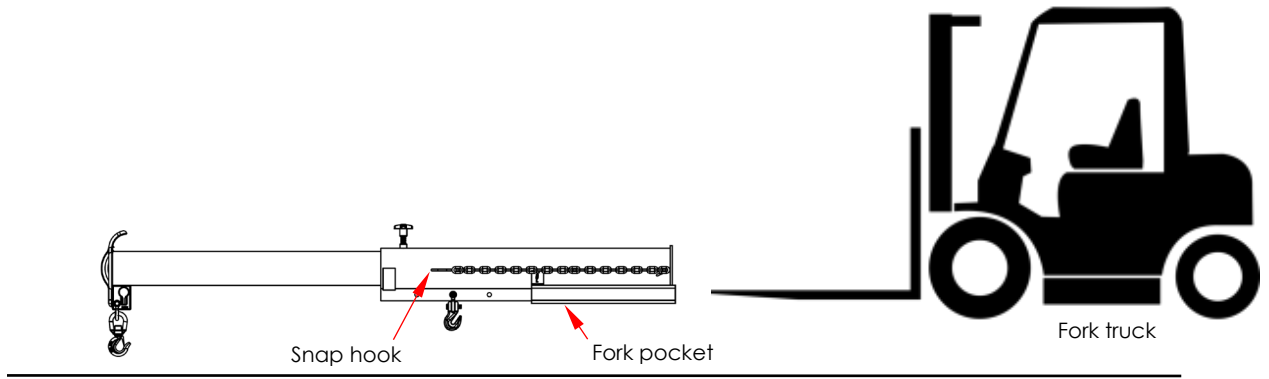

2. Securely connect the boom to the carriage of the forklift with the safety chain.
  - Wrap the safety chain around the fork carriage and fasten the snap hook to the chain/strap. There should be no slack in the chain/strap. The sole purpose of the safety chain is to prevent the boom from sliding off of the forks. It is NOT intended or designed to bear the full load rating.

3. **[Telescoping models only]** Adjust the boom length:
  - a. Loosen the X-handle locking bolt ("locking bolt"), by turning it counterclockwise.
  - b. Grasp the adjustment handle at the end of the boom and pull the boom to the desired length.
  - c. Tighten the locking bolt by turning it clockwise.

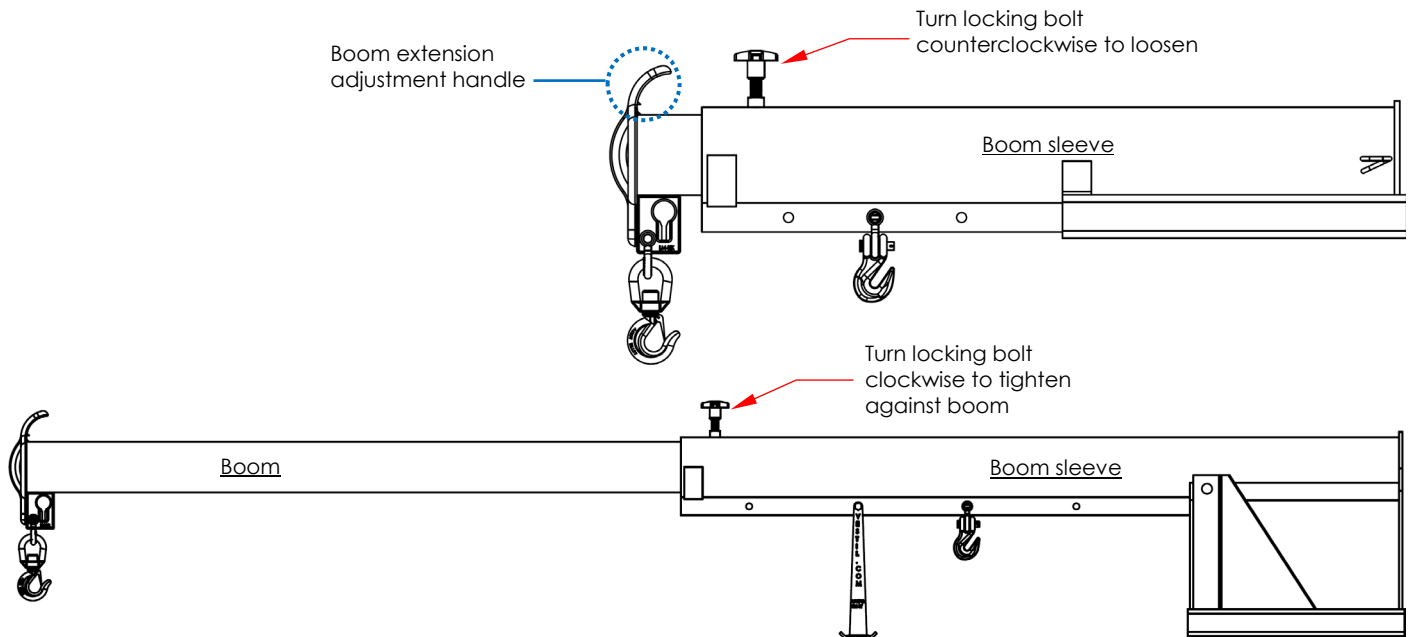

## WARNING

Material handling is dangerous. Improper use of this product might result in serious personal injuries.

- Confirm that the load weighs less than the maximum rated load of your boom AND that your fork lift is rated to lift the combined weight of the boom and the load.
- Contact the manufacturer of your fork lift BEFORE using the boom. Request that the lift manufacturer provide:
  1. Written approval to use the boom with your lift truck; AND
  2. Markings (labels) for the lift truck that:
    - Identify your LM-boom; AND
    - Provide the approximate net weight of the forklift truck and boom at the maximum fork elevation with a laterally-centered load. [29 CFR 1910.178(a)(5)].
- DO NOT use the boom until the forklift manufacturer provides adjusted maximum rated load tags for your fork lift.
- DO NOT attempt to lift loads weighing more than the rated load of either the boom or lift truck, **whichever is smaller**. Maximum rated load information appears in the tables on pages 4 & 6.
- Strictly adhere to all rules applied at your worksite regarding forklift operation, fork attachment usage, and load rigging.
- ONLY use rigging having maximum load ratings that exceed the load weight.
- DO NOT connect a load to only 1 hook, which will cause the load to rotate during lifting and transport operations. Loads should connect to both hooks simultaneously.

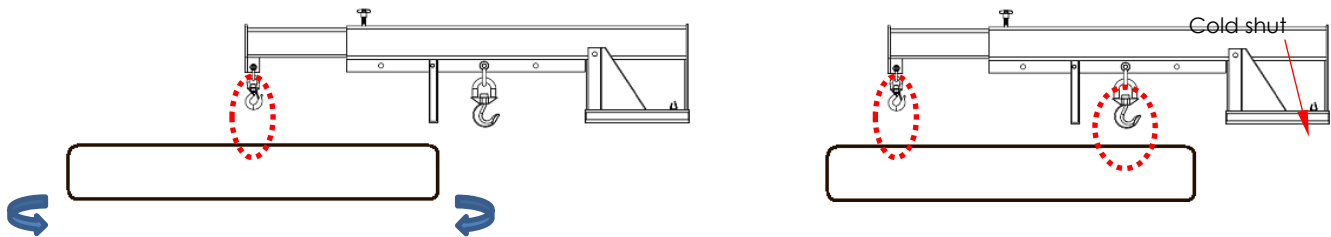

**Test the stability of the load in the rigging.** Raise the forks *slowly* to minimize load movement. Raise the forks until the load is entirely suspended from the boom. Watch the load and boom closely for *either* of the following issues: 1) Load movement in rigging; or 2) Boom sliding towards tips of forks. If you notice either issue, immediately lower the forks and adjust the rigging. Retest the stability of the load in the rigging

- While transporting a load with the boom, the load should only be 6-8 inches above the ground. Adjust load height to avoid obstacles along the travel path.
- DO NOT exceed approximately 1.5mph (2.4kph) while transporting a load with the boom.
- Travel **ONLY** on smooth, level surfaces. Turn slowly and smoothly.
- If the load is unstable while suspended, DO NOT use the boom.

4. Attach the load to the boom by connecting the load to appropriate rigging. Attach the rigging to the end hook or to both the end hook and the stabilizing hook (see diagram below).

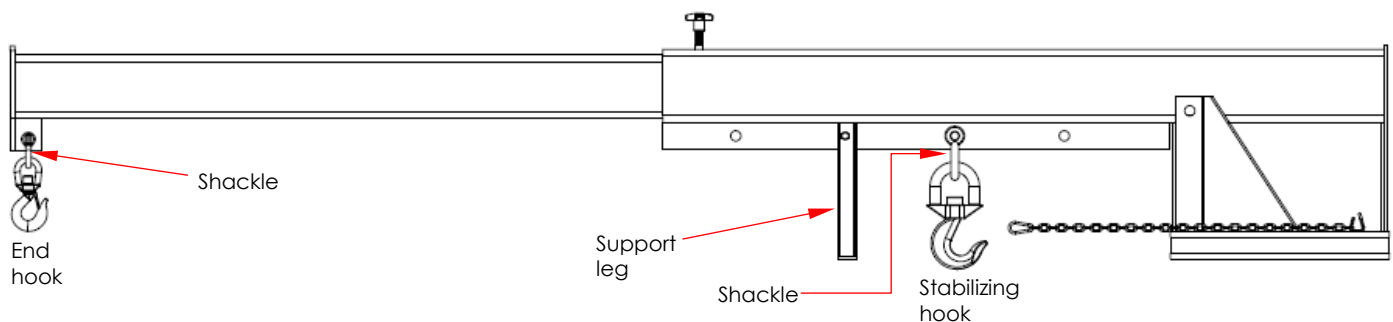



## RECORD OF SATISFACTORY CONDITION

Record the condition of the lifting boom before putting it into service. Measure the length and width of the shackle of both hooks. Include a width measurement of the mouth of the shackle, i.e. the area that receives the shackle pin. Record your measurements. Measure the mouth of both hooks and record the measurements. Thoroughly photograph the unit from multiple angles. Include close range photos of all labeling, the shackles and shackle pins, the fork pockets/tubes, safety chain and its snap hook and cold shut, support leg, and welds. Collate all photographs and writings into a single file. Mark the file appropriately to identify it. The file provides a record of the device in satisfactory condition. Compare the results of all [INSPECTIONS](#) (see p. 10) to this *RECORD* to determine whether the unit is in satisfactory condition. If the boom is not in satisfactory condition, repair it before returning it to service. Purely cosmetic changes, like damaged paint/powdercoat, do not constitute changes from satisfactory condition. However, touchup paint should be applied to all affected areas as soon as cosmetic damage occurs to prevent rusting and corrosion. If left unaddressed, rusting/corrosion will alter the device from satisfactory condition and could make it unsafe to use.

## LOAD TESTS

After creating a [RECORD OF SATISFACTORY CONDITION](#) and before using the boom for the first time, a qualified person should conduct a load test. The test load should be 125% of the rated load (capacity) of the lifter. For instance, if the rated load (capacity) is 1,000 lb. (454.5kg) the test load should be 1,250 pounds (568.2kg). Raise the load off of the ground until it is entirely suspended from the boom. Leave the load suspended for a few minutes. Return it to the ground and unload it. Perform a [MONTHLY INSPECTION](#) as described in the [INSPECTIONS](#) section (p. 10). The boom should undergo load testing immediately after it is repaired, modified, or altered. Never modify the boom without first receiving written approval from Vestil.

## INSPECTIONS

Inspections and repairs should only be performed by qualified persons. Compare the results of each inspection to the [RECORD OF SATISFACTORY CONDITION](#) (the "RECORD"). Do not use the lifter unless all parts are in satisfactory condition. Replace parts that are not in satisfactory condition before using the lifter again. **DON'T GUESS! If you have any questions about the condition of your boom, contact the [TECHNICAL SERVICE](#) department.** The phone number is provided on the cover page of this manual. *Never make temporary repairs of damaged or missing parts.* Only use manufacturer-approved replacement parts. Replace the entire unit if it cannot be restored to satisfactory condition.

### WARNING

Immobilize the boom before conducting inspections and performing maintenance. **If an inspection reveals problems, restore the boom to normal operating condition BEFORE using it again.** DO NOT use a boom that is structurally damaged in any way. Structural damage includes, but is not limited to, cracked welds, warping or deformation of the fork pockets, support leg, frame members, boom, or boom sleeve.

- Before each use** – Visually examine the boom for cracks, severe rusting/corrosion, damaged hooks and/or shackles, and damaged support leg.
- Monthly inspection** — At least once per month, and before using the boom for the first time, inspect the following components for conditions that might interfere with normal operation.
  - Frame and fork pockets** — Fork pockets should be square and solid. Each pocket should be rigidly welded to the frame. Look for significant wear, damage, or indications of metal fatigue to any portion of the fork pockets, support frame, boom, or boom sleeve.
  - Boom** — Check all welds. The boom should be straight and undamaged, i.e. no cracks, punctures, warps, etc. Telescoping models should slide without binding inside the receiver/sleeve.
  - Safety chain** — All links of the chain should be intact and of equal dimensions. Chains should be securely attached to the frame by means of a lap link. The snap hook at the end of the chain should close completely and automatically.
  - Hooks and shackles** — Examine the end hook & the stabilizing hook. Record a measurement of the throat opening of each hook. Compare the measurements with those taken during the very first inspection. Replace a hook if its throat opening is more than 15 percent wider than the original throat opening measurement, or if the hook is twisted more than 10° from the plane of the unbent hook. Discard damaged hooks. The latch of the end hook should close automatically. Shackles should be securely attached to the underside of the boom. Examine all pins that attach shackles to the boom for cracks and warps.
  - Locking bolt (telescoping models)** — Confirm the locking bolt can solidly engage the top of the boom.
  - Support leg** — Inspect the support leg. It should be straight, undamaged (no cracks or deformations), and securely attached to the underside of the boom.
  - Labeling** — The product should always be labeled as shown in the [LABELING DIAGRAM](#) on p. 27. Replace any label that is damaged, significantly faded, or not easily readable from a reasonable distance.
- Annual Lift Test** – At least once per year, perform a [LOAD TEST](#) (p. 9) of the boom. Afterwards, conduct a [MONTHLY INSPECTION](#). Confirm [SATISFACTORY CONDITION](#) before returning it to service.

## MAINTENANCE

Implement a maintenance program to ensure that the boom remains in normal operating condition. The following steps should be utilized in conjunction with maintenance procedures applicable to fork truck attachments provided in the most recent edition of ANSI B56.1.

**Step 1:** Tag the boom, "Out of Service."

**Step 2:** Remove dirt and other matter from all surfaces.

**Step 3:** Conduct a Monthly inspection. If severe deformities, corrosion, rusting, or excessive wear of structural members is found, DO NOT use the product.

**Step 4:** Perform all necessary adjustments, replacements and/or repairs but DO NOT modify the boom.

### WARNING

DO NOT return the boom to service until all necessary adjustments and repairs are complete! An adjustment is a simple correction that restores the boom to [SATISFACTORY CONDITION](#), such as tightening loose fasteners or removing debris from surfaces. Repair means removal of worn parts and installation of replacement parts. A "modification" is a change that alters the boom from original condition, like bending the structural members or removing parts. **NEVER** modify the boom without the express, written approval of Vestil. Modifications might make the boom unsafe to use and automatically void the [LIMITED WARRANTY](#).

**Step 5:** Make a dated record of all repairs, adjustments, and replacements performed.

# LABELING DIAGRAM

The unit should be labeled as shown in the diagram. However, label content and location are subject to change so your product might not be labeled exactly as shown. Compare this diagram to your RECORD OF SATISFACTORY CONDITION. Replace all labels that are damaged, missing, or not easily readable (e.g. faded). Order replacement labels by contacting the PARTS DEPARTMENT online at [http://www.vestilmfg.com/parts\\_info.htm](http://www.vestilmfg.com/parts_info.htm). Alternatively, you may request replacement parts and/or service by calling (260) 665-7586 and asking the operator to connect you to the PARTS DEPARTMENT.

## Either label 962 (LMS-EBT) or 963 (LMS-EBNT) (on either fork pocket)

**⚠ WARNING**

Material handling is inherently dangerous; improper use of this product might result in serious personal injuries sustained by the operator and/or bystanders. To reduce the risks:

- DO NOT use if safety chain/strap is damaged or absent.
- Law requires you to contact manufacturer of your (fork) lift truck BEFORE using boom to request:
  1. Written approval to use boom with lift truck [29 CFR 1910.178(a)(4)];
  2. Markings (labels) for lift truck that:
    - Identify this fork-mounted boom; AND
    - Give approximate net weight of truck and boom at maximum fork elevation with laterally-centered load. [29 CFR 1910.178(a)(5)]
- DO NOT use boom UNTIL lift truck manufacturer provides corrected maximum rated load tags for your forklift truck.
- DO NOT attempt to lift more than the rated load of the boom or lift truck, whichever is smaller. The table below shows the maximum rated load of the boom ONLY; you MUST compare the appropriate table entry with the corrected maximum rated load provided by the fork truck manufacturer.

**⚠ ADVERTENCIA**

La manipulación de materiales es inherentemente peligrosa; uso impropio de este producto podría resultar en daños personales serios al operador y/o a los espectadores. Para reducir los riesgos:

- NO use si la cadena/correa de seguridad está dañada o ausente
- No hay require que se ponga en contacto con el fabricante de su (horquilla) camioneta elevadora ANTES de usar el auge para perder:
  1. Aprobación por escrito para el uso del auge con la camioneta elevadora [29 CFR 1910.178(a)(4)];
  2. Marcas (etiquetas) para la camioneta elevadora que:
    - Identifiquen este auge de la horquilla montada; Y
    - Den peso neto aproximado del camion y el auge a una elevación de la horquilla máxima con la carga lateralmente centrada. [29 CFR 1910.178(a)(5)]
- NO use el auge HASTA que el fabricante de la camioneta elevadora le haya proveído con las etiquetas de la correcta carga máxima tasada para su camioneta elevadora.
- NO intente elevar más de la carga tasada del auge o camioneta elevadora, lo que sea menor. La table a continuación del ensaña la máxima carga tasada para EL AUJE SOLO. DEBE comparar la table con la correcta carga máxima tasada de la etiqueta que el fabricante le ha proveído.

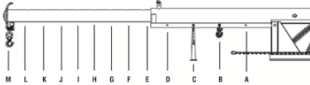

Weight of LM-boom by model: (Peso del LM-Auge por modelo)	LM-OBT-4k	405 (-184 kg)
LM-OBT-6k	456 (-207.3 kg)	
LM-OBT-8k	622 (-283 kg)	

Hook position (Posición del gancho)	A	B	C	D	E	F	G	H	I	J	K	L	M
Distance from outer edges of fork pockets in inches (cm) (Distancia desde los extremos exteriores de los bolsillos de las horquillas en cm)	36 (-91)	48 (-122)	60 (-152)	72 (-183)	84 (-213)	91.5 (-232)	99 (-251)	106.5 (-271)	114 (-290)	121.5 (-309)	129 (-328)	136.5 (-347)	144 (-366)

Maximum rated load in pounds (kg) of a load suspended from a single hook located at the corresponding "Hook position". (Máxima carga tasada en pounds (kg) de la carga suspendida desde un solo gancho localizado a la correspondiente posición del gancho.)	LM-OBT-4k (-1820)	LM-OBT-6k (-2727)	LM-OBT-8k (-3636)
A	4000 (-1790)	3750 (-1699)	3500 (-1588)
B	3750 (-1699)	3500 (-1588)	3250 (-1477)
C	3500 (-1588)	3250 (-1477)	3000 (-1366)
D	3250 (-1477)	3000 (-1366)	2845 (-1293)
E	3000 (-1366)	2845 (-1293)	2690 (-1220)
F	2845 (-1293)	2690 (-1220)	2535 (-1148)
G	2690 (-1220)	2535 (-1148)	2380 (-1075)
H	2535 (-1148)	2380 (-1075)	2225 (-1002)
I	2380 (-1075)	2225 (-1002)	2070 (-929)
J	2225 (-1002)	2070 (-929)	1915 (-856)
K	2070 (-929)	1915 (-856)	1760 (-783)
L	1915 (-856)	1760 (-783)	1605 (-710)
M	1760 (-783)	1605 (-710)	1450 (-637)

## Label 1153 (on either fork pocket)

MODEL / MODÉLO / MODÈLE _____
WEIGHT / PESO / MASS _____
CAPACITY / CAPACIDAD / CAPACITÉ _____
SERIAL / SERIE / SÉRIE _____
UNITS: 2.2 lb. = 1kg      1" (or 1in.) = 2.54cm <b>1153</b>



## Label 218 (on either fork pocket)

**⚠ WARNING**

Improper use might result in death or serious personal injury. Attach device to fork carriage with safety chain/strap.

- Drive lift truck forward until forks contact ends of fork pockets.
- Chain/straps must not be able to disconnect (slide free) from carriage.
- Safety chain/strap must be taut. Connect chain/strap to carriage via shortest line.

**⚠ ADVERTENCIAS**

El uso impropio puede resultar en muerte o heridas personales. Atar aparato al mástil del montacargas con cadenas/correas.

- Maneje el montacargas para adelante hasta que las cuñas hagan contacto con la orilla del bolsillo de las cuñas.
- La cadenas y correas no deben de deslizarse (soltarse) del mástil del montacargas.
- La cadena/correa de seguridad debe de estar apretado. Asegure la cadena/correa al mástil via la ruta mas corta.

**218**  
rev 0910

## LIMITED WARRANTY

Vestil Manufacturing Corporation ("Vestil") warrants this product to be free of defects in material and workmanship during the warranty period. Our warranty obligation is to provide a replacement for a defective, original part covered by the warranty after we receive a proper request from the Warrantee (you) for warranty service.

### Who may request service?

Only a warrantee may request service. You are a warrantee if you purchased the product from Vestil or from an authorized distributor AND Vestil has been fully paid.

### Definition of "original part"?

An original part is a part used to make the product as shipped to the Warrantee.

### What is a "proper request"?

A request for warranty service is proper if Vestil receives: 1) a photocopy of the Customer Invoice that displays the shipping date; AND 2) a written request for warranty service including your name and phone number. Send requests by one of the following methods:

#### US Mail

Vestil Manufacturing Corporation  
2999 North Wayne Street, PO Box 507  
Angola, IN 46703

#### Fax

(260) 665-1339  
Phone  
(260) 665-7586

#### Email

[info@vestil.com](mailto:info@vestil.com)  
Enter "Warranty service request"  
in subject field.

In the written request, list the parts believed to be defective and include the address where replacements should be delivered. After Vestil receives your request for warranty service, an authorized representative will contact you to determine whether your claim is covered by the warranty. Before providing warranty service, Vestil will require you to send the entire product, or just the defective part (or parts), to its facility in Angola, IN.

### What is covered under the warranty?

The warranty covers defects in the following original, dynamic parts: motors, hydraulic pumps, motor controllers, and cylinders. It also covers defects in original parts that wear under normal usage conditions ("wearing parts"), such as bearings, hoses, wheels, seals, brushes, and batteries.

### How long is the warranty period?

The warranty period for original dynamic components is 1 year. For wearing parts, the warranty period is 90 days. Both warranty periods begin on the date Vestil ships the product to the Warrantee. If the product was purchased from an authorized distributor, the periods begin when the distributor ships the product. Vestil may, at its sole discretion, extend a warranty period for products shipped from authorized distributors by up to 30 days to account for shipping time.

### If a defective part is covered by the warranty, what will Vestil do to correct the problem?

Vestil will provide an appropriate replacement for any covered part. An authorized representative of Vestil will contact you to discuss your claim.

### What is not covered by the warranty?

The Warrantee (you) is responsible for paying labor costs and freight costs to return the product to Vestil for warranty service.

### Events that automatically void this Limited Warranty.

- Misuse;
- Negligent assembly, installation, operation or repair;
- Installation/use in corrosive environments;
- Inadequate or improper maintenance;
- Damage sustained during shipping;
- Collisions or other accidents that damage the product;
- Unauthorized modifications: Do not modify the product IN ANY WAY without first receiving written authorization from Vestil.

### Do any other warranties apply to the product?

Vestil Manufacturing Corp. makes no other express warranties. All implied warranties are disclaimed to the extent allowed by law. Any implied warranty not disclaimed is limited in scope to the terms of this Limited Warranty. Vestil makes no warranty or representation that this product complies with any state or local design, performance, or safety code or standard. Noncompliance with any such code or standard is not a defect in material or workmanship.

