



VESTIL MANUFACTURING CORP.
 2999 North Wayne Street, P.O. Box 507, Angola, IN 46703
 Telephone: (260) 665-7586 -or- Toll Free (800) 348-0868
 Fax: (260) 665-1339
 www.vestilmfg.com e-mail: sales@vestil.com

JIB-P-Series Multi-Station Jib Cranes Instruction Manual



Receiving instructions:

After delivery, IMMEDIATELY remove the packaging from the product. Inspect the product closely to determine whether it sustained damage during transport. **If damage is discovered, immediately record a complete description of the damage on the bill of lading.** If the product is undamaged, discard the packaging.

NOTICES:

- 1) Compliance with laws, regulations, codes, and non-voluntary standards enforced in the location where the product is *used* is exclusively the responsibility of the owner/end-user.
- 2) VESTIL is **not liable** for any injury or property damage that occurs as a consequence of failing to apply either:
 - a) Instructions in this manual; or
 - b) Information provided on labels affixed to the product.

Vestil is not responsible for *any* consequential damages sustained while assembling, using, or maintaining this product.

Table of Contents

Crane specifications.....	2
Signal words.....	2
Safe use recommendations.....	3
Function tests.....	3
FIGS. 1-3: Exploded parts diagrams and bills of materials.....	4 - 6
Assembly instructions.....	7 - 9
Operation instructions.....	10-11
Inspections & Maintenance.....	11-12
Labeling diagram.....	13
Limited warranty.....	14

Crane Specifications:

Crane dimensions and net weight appear in the table below.

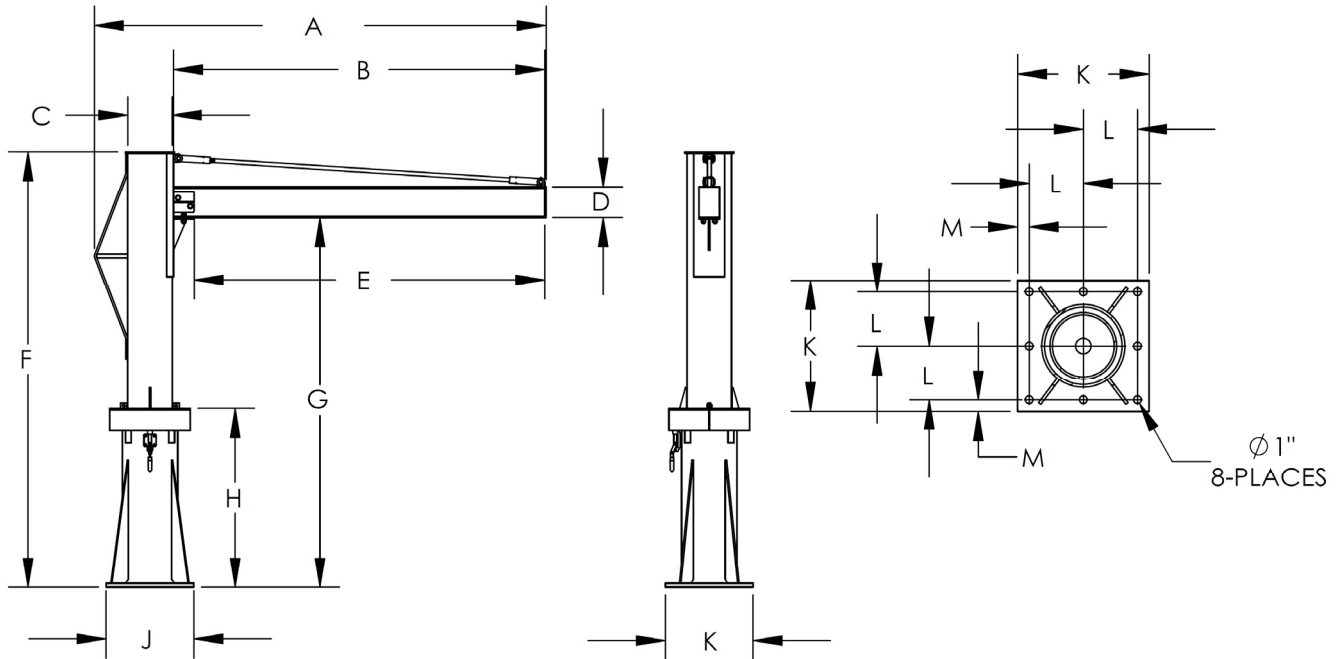

Model	A	B	C	D	E	F	G	H	J	K	L	M	Net wt.
JIB-P-10-6-6	87 ³ / ₈ "	72"	8 ⁵ / ₈ "	6"	67 ³ / ₄ "	84 ¹¹ / ₁₆ "	71 ¹³ / ₁₆ "	34 ³ / ₄ "	17"	17"	7"	1 ¹ / ₂ "	552 lb.
JIB-P-10-6-8	87 ³ / ₈ "	72"	8 ⁵ / ₈ "	6"	67 ³ / ₄ "	108 ¹¹ / ₁₆ "	95 ¹³ / ₁₆ "	34 ³ / ₄ "	17"	17"	7"	1 ¹ / ₂ "	614 lb.
JIB-P-10-6-10	87 ³ / ₈ "	72"	8 ⁵ / ₈ "	6"	67 ³ / ₄ "	132 ¹¹ / ₁₆ "	119 ¹³ / ₁₆ "	34 ³ / ₄ "	17"	17"	7"	1 ¹ / ₂ "	676 lb.
JIB-P-10-8-6	111 ³ / ₈ "	96"	8 ⁵ / ₈ "	6"	91 ³ / ₄ "	84 ¹¹ / ₁₆ "	71 ¹³ / ₁₆ "	34 ³ / ₄ "	17"	17"	7"	1 ¹ / ₂ "	579 lb.
JIB-P-10-8-8	111 ³ / ₈ "	96"	8 ⁵ / ₈ "	6"	91 ³ / ₄ "	108 ¹¹ / ₁₆ "	95 ¹³ / ₁₆ "	34 ³ / ₄ "	17"	17"	7"	1 ¹ / ₂ "	641 lb.
JIB-P-10-8-10	111 ³ / ₈ "	96"	8 ⁵ / ₈ "	6"	91 ³ / ₄ "	132 ¹¹ / ₁₆ "	119 ¹³ / ₁₆ "	34 ³ / ₄ "	17"	17"	7"	1 ¹ / ₂ "	703 lb.
JIB-P-10-10-6	135 ³ / ₈ "	120"	8 ⁵ / ₈ "	6"	115 ³ / ₄ "	84 ¹¹ / ₁₆ "	71 ¹³ / ₁₆ "	34 ³ / ₄ "	17"	17"	7"	1 ¹ / ₂ "	606 lb.
JIB-P-10-10-8	135 ³ / ₈ "	120"	8 ⁵ / ₈ "	6"	115 ³ / ₄ "	108 ¹¹ / ₁₆ "	95 ¹³ / ₁₆ "	34 ³ / ₄ "	17"	17"	7"	1 ¹ / ₂ "	668 lb.
JIB-P-10-10-10	135 ³ / ₈ "	120"	8 ⁵ / ₈ "	6"	115 ³ / ₄ "	132 ¹¹ / ₁₆ "	119 ¹³ / ₁₆ "	34 ³ / ₄ "	17"	17"	7"	1 ¹ / ₂ "	703 lb.

SIGNAL WORDS:

This manual uses SIGNAL WORDS to call attention to uses of this product that are likely to result in personal injuries or property damage. The signal words used in this manual appear below along with their definitions.

⚠ DANGER Identifies a hazardous situation which, if not avoided, **WILL** result in DEATH or SERIOUS INJURY. Use of this signal word is limited to the most extreme situations.

⚠ WARNING Identifies a hazardous situation which, if not avoided, **COULD** result in DEATH or SERIOUS INJURY.

⚠ CAUTION Indicates a hazardous situation which, if not avoided, **COULD** result in MINOR or MODERATE injury.

NOTICE Identifies practices likely to result in product/property damage, such as operation that might damage the product or other property.

Safe Use Recommendations:

Study the entire manual before using the crane. Store a copy of the manual with the crane. Read the manual to refresh your understanding of the safe operation, inspection or maintenance procedures whenever necessary.

⚠ DANGER Electrocutation might occur if the crane, hoist, or load, etc. contacts electrified wires. DO not install or use the crane in areas where the crane will contact electrified wires.

⚠ WARNING Improper or careless operation might result in serious personal injuries.

- ALWAYS apply use, inspection and maintenance recommendations contained in 29 CFR 1910.179. Contact the occupational safety and health institution of the state where the crane is used for requirements, etc. applied to jib cranes.
- DO NOT use a damaged or malfunctioning crane! Restore the crane to normal operating condition before returning it to service.
- The capacity of all JIB-P series cranes is 1,000 lb. (455 kg). The weights of the load, hoist, trolley, rigging, and all other equipment attached to the crane must be added together to determine the net weight applied to the crane. The net weight must never exceed the 1,000 lb. capacity.
- Always perform the “Function Tests” described below before each use.
- Inform all persons in the area that you are going to use the crane; instruct them to stay clear of the device and the supported load during operation.
- DO NOT stand beneath or travel under the crane when a load is suspended from the crane. DO NOT permit anyone to stand beneath or travel under the load.
- DO NOT lift people with the crane.
- ALWAYS load the crane consistently with the list of recommendations on p. 10-11. Failure to properly position a load might cause load swing and result in serious injury.
- DO NOT use the crane if any label is unreadable, damaged, or missing (see “Labeling diagram” on p. 13). Contact Vestil for replacement label(s).
- DO NOT modify the crane! Modifications automatically void the limited warranty (see p. 14) and might make the crane unsafe to use.

NOTICE This product must be properly maintained to function properly. Follow the maintenance recommendations provided in “Inspections & Maintenance” on p. 11-12.

Function Tests:

Before using the crane, verify that all mechanisms operate normally by performing tests 1-4 below. DO NOT use the crane unless all tests are successful. If an issue is discovered, tag the crane “Out of Service” and report the problem to authorized inspection and maintenance personnel.

1. Test the mast clamp. Fully engage the clamp (see p. 11); then try to rotate the crane. The crane should not be able to rotate more than an insignificant amount.
2. Test the roller bearing: disengage the mast clamp and rotate the mast in one complete clockwise rotation followed by a complete counterclockwise rotation. If you installed the crane in a confined location that restricts rotation to less than a full circle, test the bearing by rotating the crane through its full range.
3. Test the rollers. The crane should not wobble as it rotates.
4. Test the hoist and trolley according to the manufacturers’ instructions.

FIG. 1A: JIB-P-10-6-10, JIB-P-10-6-8, & JIB-P-10-6-6 Exploded Parts Diagram and Bill of Materials

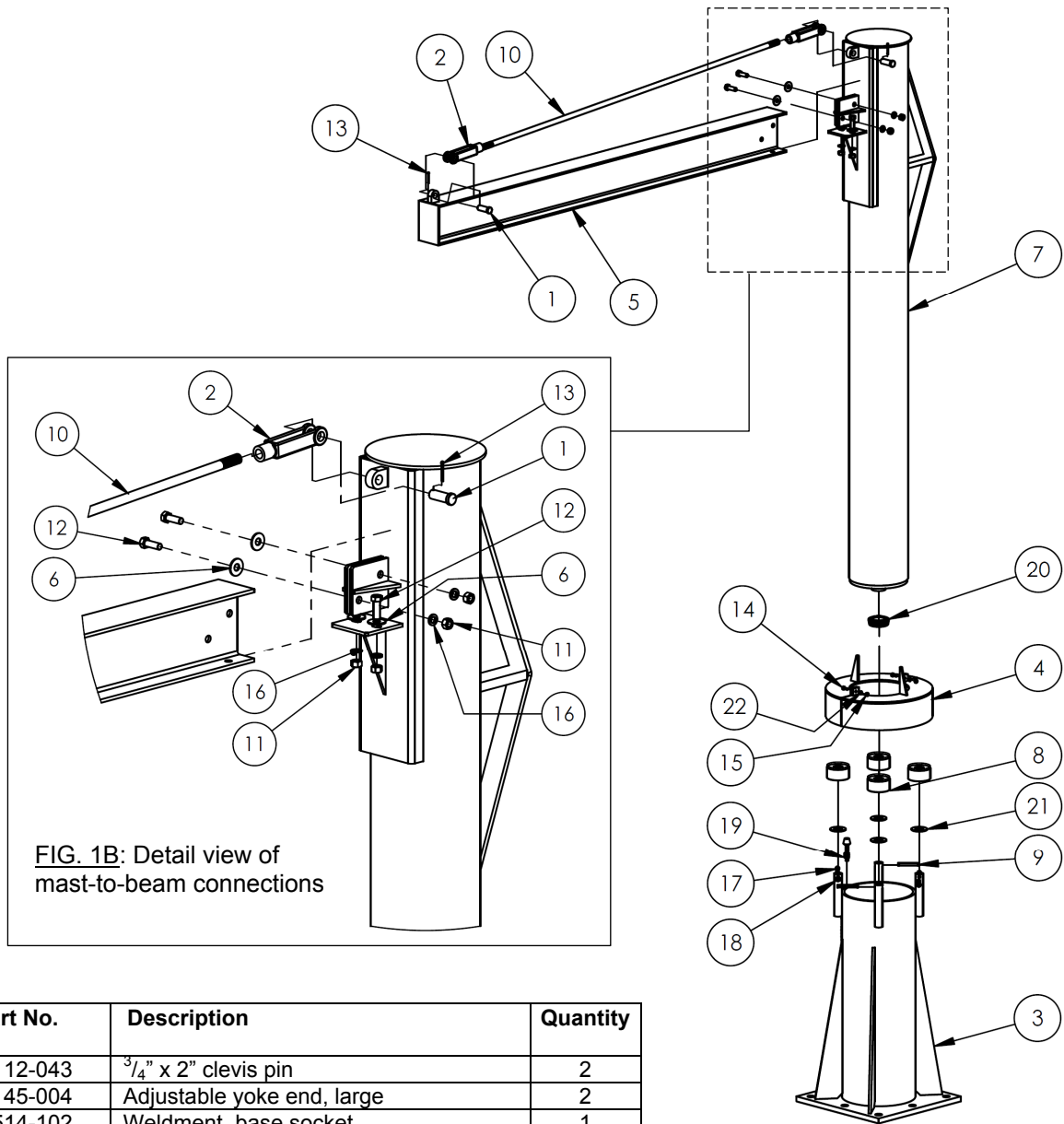

FIG. 1B: Detail view of mast-to-beam connections

Item No.	Part No.	Description	Quantity
1	28-112-043	$\frac{3}{4}$ " x 2" clevis pin	2
2	28-145-004	Adjustable yoke end, large	2
3	28-514-102	Weldment, base socket	1
4	28-524-003	Guard weldment, roller assembly	1
5	28-514-108	Weldment, I-beam, 6ft. span	1
6	33012	$\frac{1}{2}$ " flat washer, zinc finish, low carbon	4
7	28-514-103 28-514-104 28-514-105	Mast Weldment: JIB-P-10-6-10 (10ft.) JIB-P-10-6-8 (8ft.) JIB-P-10-6-6 (6ft.)	1 1 1
8	05-527-300	Roller assembly	4
9	64319	$\frac{3}{4}$ " x 3" spring pin	2
10	28-014-153	Frame, tie rod support, 6ft. span	1
11	36310	$\frac{1}{2}$ " -13 UNC #5 zinc-plated hex nut	4
12	13209	$\frac{1}{2}$ " -13 x $1\frac{1}{2}$ " HHCS #5 zinc-plated bolt	4
13	65078	$\frac{1}{8}$ " x $1\frac{1}{2}$ " zinc-plated cotter pin	2
14	13003	$\frac{1}{4}$ " - 20 x $\frac{3}{4}$ " #5 zinc-plated bolt	2
15	36302	$\frac{1}{4}$ " - 20 #5 zinc-plated hex nut	2
16	33626	$\frac{1}{2}$ " zinc-plated lock washer	4
17	26335	$\frac{3}{8}$ " x 2" shoulder screw	2
18	37021	$\frac{5}{16}$ " - 18 zinc-plated lock nut	2
19	20-037-030	Lock, rubber cap bolt and nuts	1
20	28-110-001-001	Inner bearing	1
21	33098	$1\frac{1}{8}$ " SAE flat washer, zinc-plated	4
22	33618	Medium split lock washer, $\frac{1}{4}$ "	2

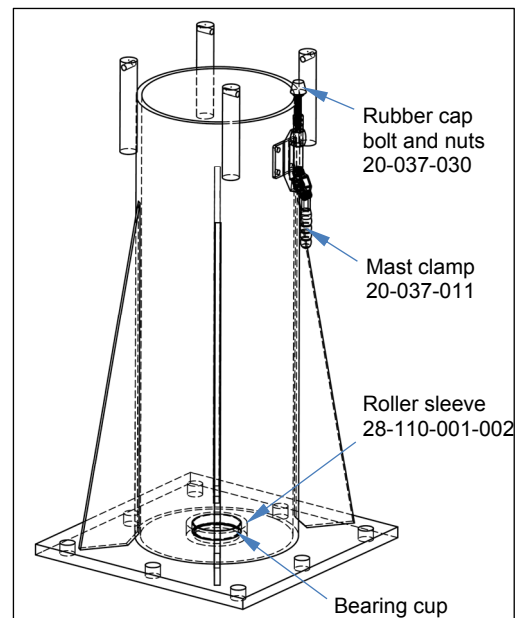
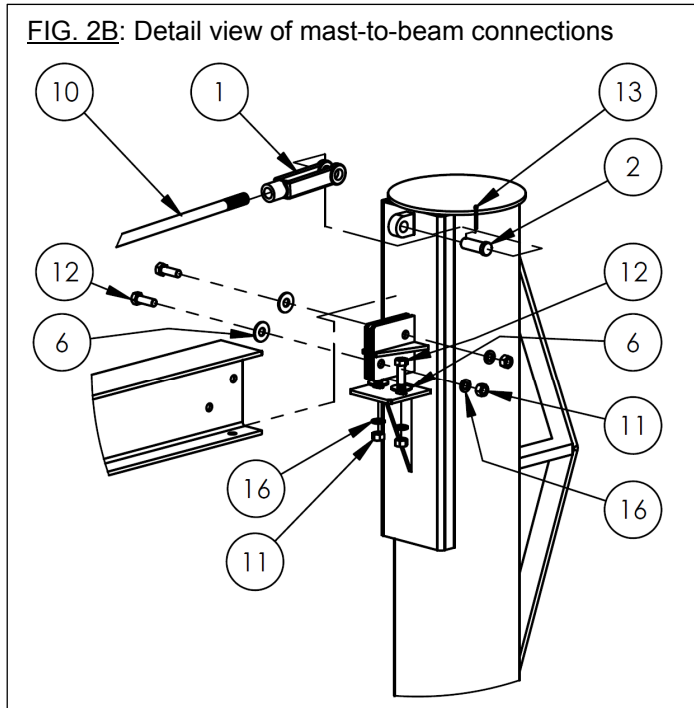
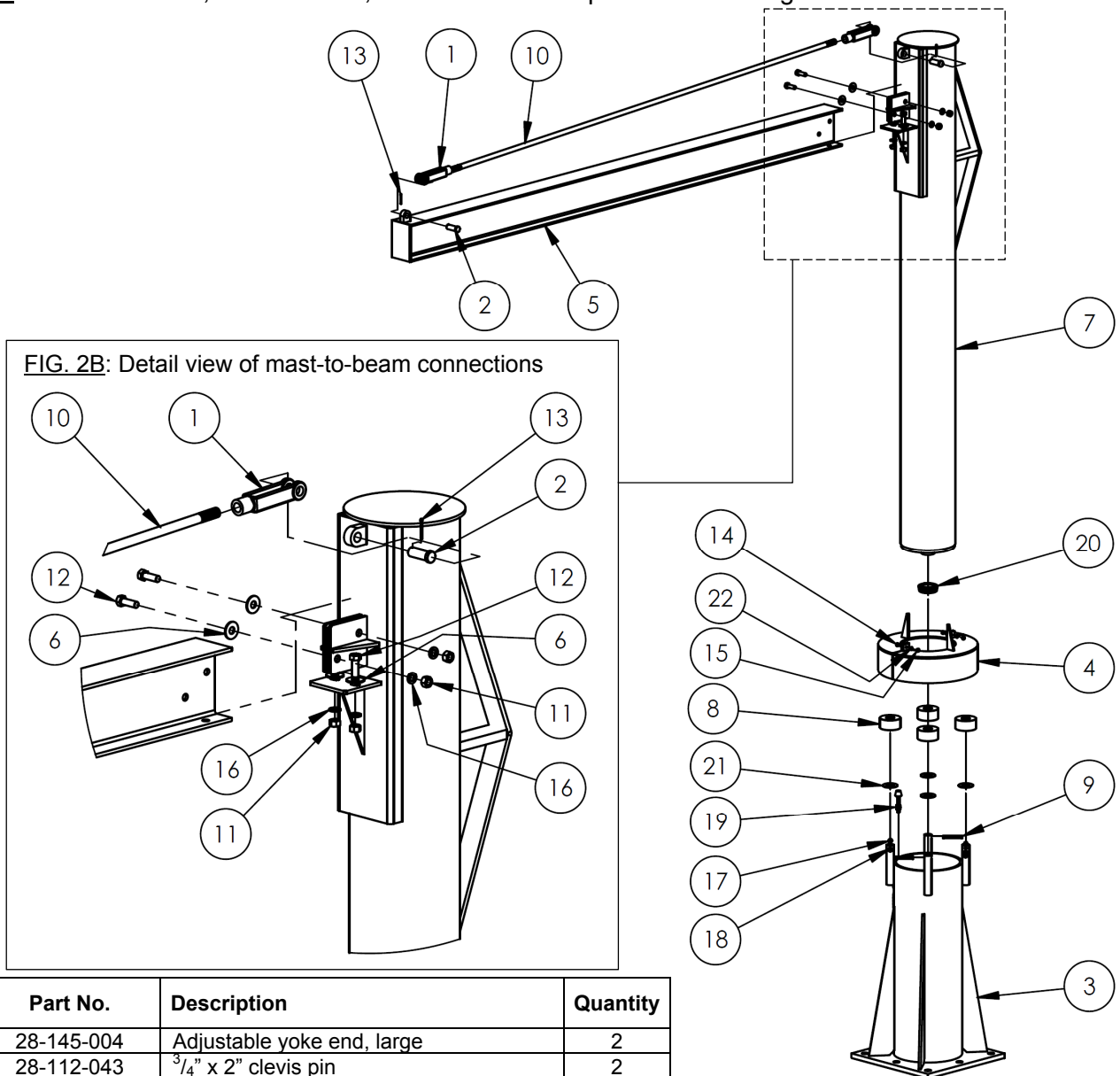

FIG. 2A: JIB-P-10-8-10, JIB-P-10-8-8, & JIB-P-10-8-6 Exploded Parts Diagram and Bill of Materials



Item No.	Part No.	Description	Quantity
1	28-145-004	Adjustable yoke end, large	2
2	28-112-043	³ / ₄ " x 2" clevis pin	2
3	28-514-102	Weldment, base socket	1
4	28-524-003	Guard weldment, roller assembly	1
5	28-514-107	Weldment, I-beam, 8ft. span	1
6	33012	¹ / ₂ " flat washer, zinc finish, low carbon	4
7	28-514-103 28-514-104 28-514-105	Mast Weldment: JIB-P-10-8-10 (10ft.) JIB-P-10-8-8 (8ft.) JIB-P-10-8-6 (6ft.)	1 1 1
8	05-527-300	Roller assembly	4
9	64319	³ / ₄ " x 3" spring pin	2
10	28-014-152	Frame, tie rod support, 8ft. span	1
11	36310	¹ / ₂ " -13 UNC #5 zinc-plated hex nut	4
12	13209	¹ / ₂ " -13 x ¹ / ₂ " HHCS #5 zinc-plated bolt	4
13	65078	¹ / ₈ " x ¹ / ₂ " zinc-plated cotter pin	2
14	13003	¹ / ₄ " - 20 x ³ / ₄ " #5 zinc-plated bolt	2
15	36302	¹ / ₄ " - 20 #5 zinc-plated hex nut	2
16	33626	¹ / ₂ " zinc-plated lock washer	4
17	26335	³ / ₈ " x 2" shoulder screw	2
18	37021	⁵ / ₁₆ " - 18 zinc-plated lock nut	2
19	20-037-030	Lock, rubber cap bolt and nuts	1
20	28-110-001-001	Inner bearing	1
21	33098	¹ / ₈ " SAE flat washer, zinc-plated	4
22	33618	Medium split lock washer, ¹ / ₄ "	2

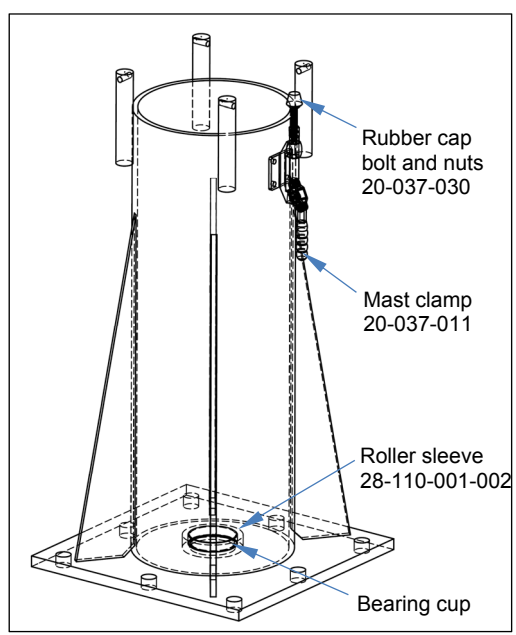
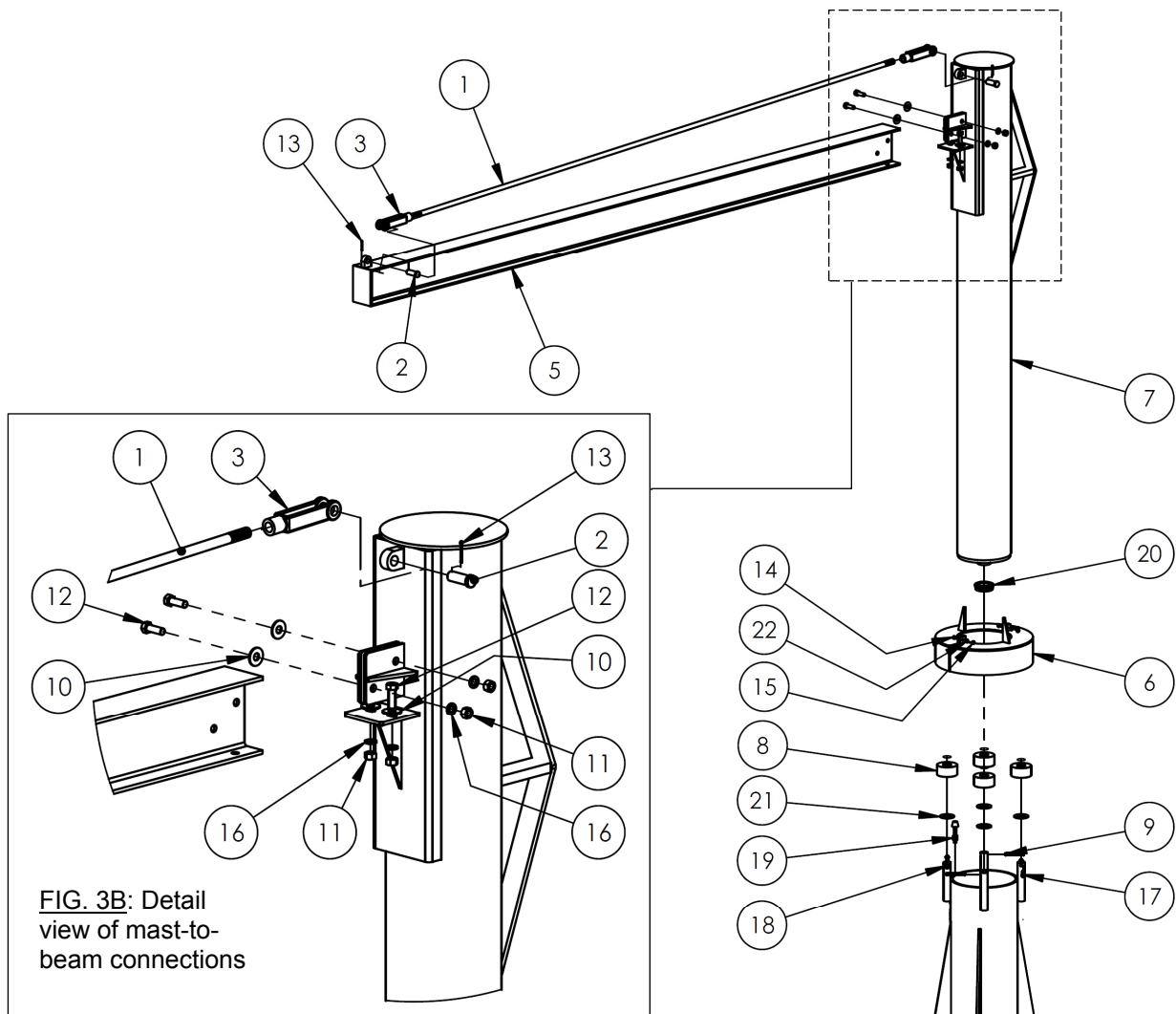
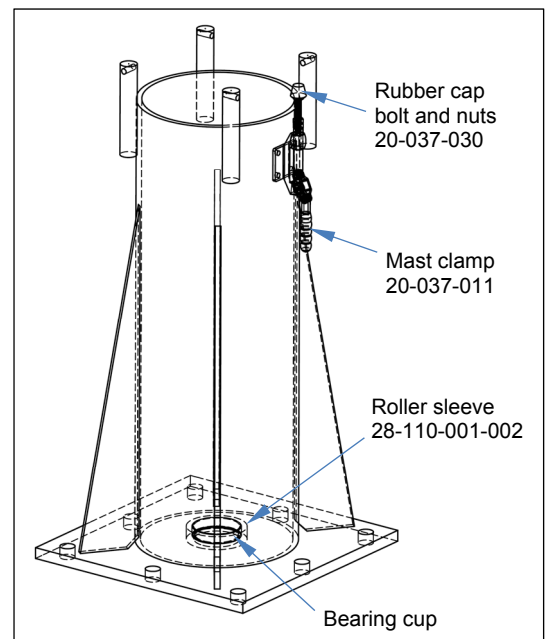

FIG. 3A: JIB-P-10-10-10, JIB-P-10-10-8, & JIB-P-10-10-6 Exploded Parts Diagram and Bill of Materials



Item No.	Part No.	Description	Quantity
1	28-014-151	Frame, tie rod support, 10ft. span	1
2	28-112-043	$\frac{3}{4}$ " x 2" clevis pin	2
3	28-145-004	Adjustable yoke end, large	2
4	28-514-102	Weldment, base socket	1
5	28-514-106	Weldment, I-beam, 10ft. span	1
6	28-524-003	Guard weldment, roller assembly	1
7	28-514-103	Mast Weldment: JIB-P-10-10-10 (10ft.)	1
	28-514-104	JIB-P-10-10-8 (8ft.)	1
	28-514-105	JIB-P-10-10-6 (6ft.)	1
8	05-527-300	Roller assembly	4
9	64319	$\frac{3}{4}$ " x 3" spring pin	2
10	33012	$\frac{1}{2}$ " flat washer, zinc finish, low carbon	4
11	36310	$\frac{1}{2}$ " -13 UNC #5 zinc-plated hex nut	4
12	13209	$\frac{1}{2}$ " -13 x $1\frac{1}{2}$ " HHCS #5 zinc-plated bolt	4
13	65078	$\frac{1}{8}$ " x $1\frac{1}{2}$ " zinc-plated cotter pin	2
14	13003	$\frac{1}{4}$ " - 20 x $\frac{3}{4}$ " #5 zinc-plated bolt	2
15	36302	$\frac{1}{4}$ " - 20 #5 zinc-plated hex nut	2
16	33626	$\frac{1}{2}$ " zinc-plated lock washer	4
17	26335	$\frac{3}{8}$ " x 2" shoulder screw	2
18	37021	$\frac{5}{16}$ " - 18 zinc-plated lock nut	2
19	20-037-030	Lock, rubber cap bolt and nuts	1
20	28-110-001-001	Inner bearing	1
21	33098	$1\frac{1}{8}$ " SAE flat washer, zinc-plated	4
22	33618	Medium split lock washer, $\frac{1}{4}$ "	2



Assembly Instructions:

Step 1: Create the foundation for the base socket and fasten socket to foundation.

Required materials:

- 1) ~1 cubic yard of 3,000psi concrete
- 2) Eight 7/8" x 30" J-Hook anchor bolts
- 3) Eight 7/8" jam (leveling) nuts
- 4) Eight 7/8" lock nuts
- 5) Mortar Mix (grout) to fill 17" x 17" x 1" volume
- 6) 3/4" rebar
- 7) 5/8" rebar

FIG. 4A: Foundation

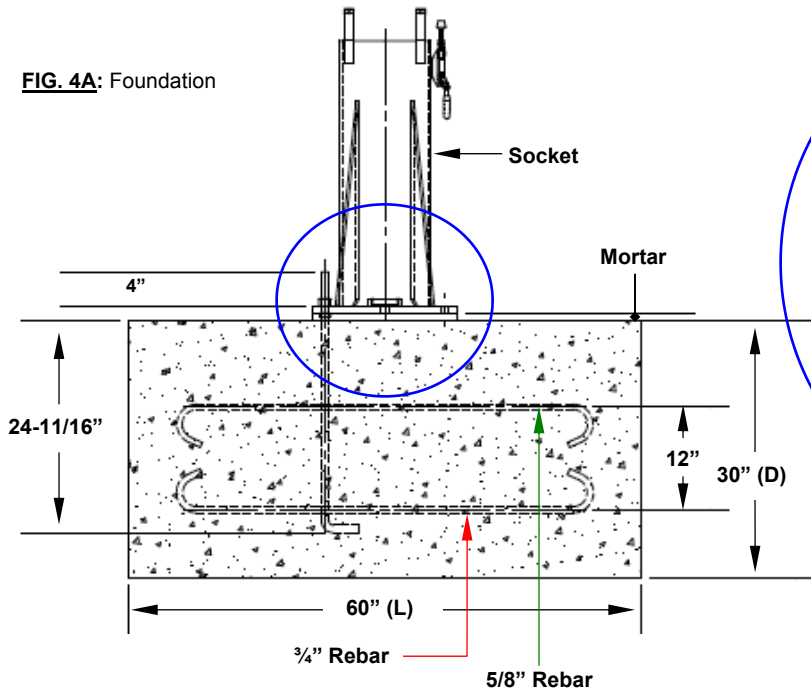

FIG 4B: Socket Attachment Detail View

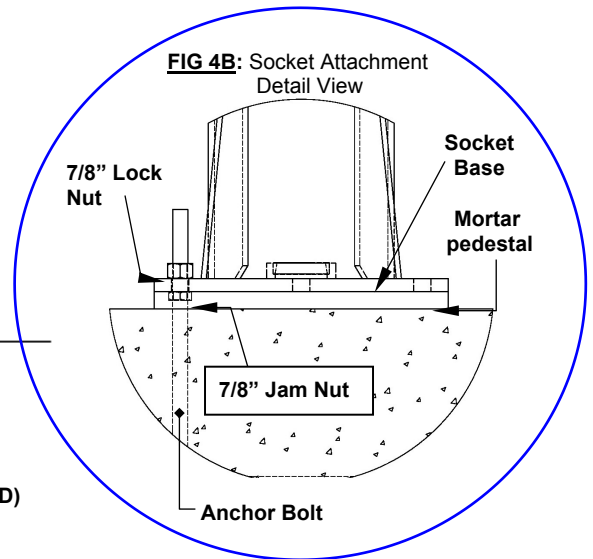
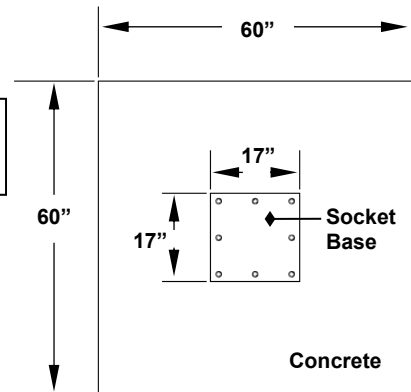

FIG. 4C: Bird's Eye View of Concrete Pad



a. Pour the 60" (L) x 60" (W) x 30" (D) reinforced concrete pad as diagrammed in Fig. 4A, 4B, & 4C. Allow concrete to cure completely according to the instructions provided with the concrete mixture.

b. After the foundation hardens, wind a 7/8" jam nut onto the threaded portion of each anchor bolt that projects from the surface of the concrete. Level across the jam nuts; then form a pedestal from mortar by filling the square area around and inside the anchor bolts with grout (mortar mix). The grout should be flush with the top of the jam nuts.

c. Lower the socket base plate onto the anchor bolts until it rests squarely on the jam nuts and grout pedestal. Wind the lock nuts onto the anchor bolts.

d. Plumb the socket at 90° positions to confirm that the socket is vertical. Adjust the leveling (jam) nuts to plumb the mast.

e. Fill the space between the base plate and the grout pedestal with more grout as necessary. Allow the grout to harden completely according to the directions supplied with the mixture.

FIG. 4D: Plumb Socket (bird's eye view)

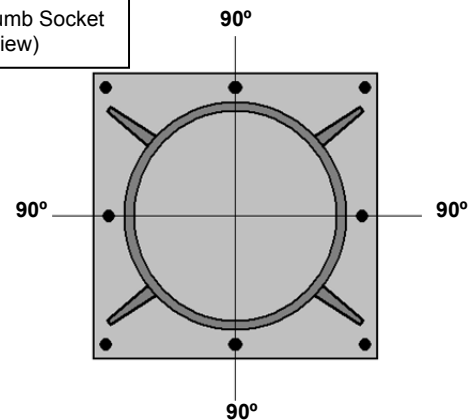

Step 2a: Fasten I-Beam to Mast

NOTE: Also refer to FIGS. 1B, 2B, and 3B on pages 4-6.

Insert I-beam into the vertical boom bracket on the mast. The I-beam should rest on the support bracket so that the bolt holes align.

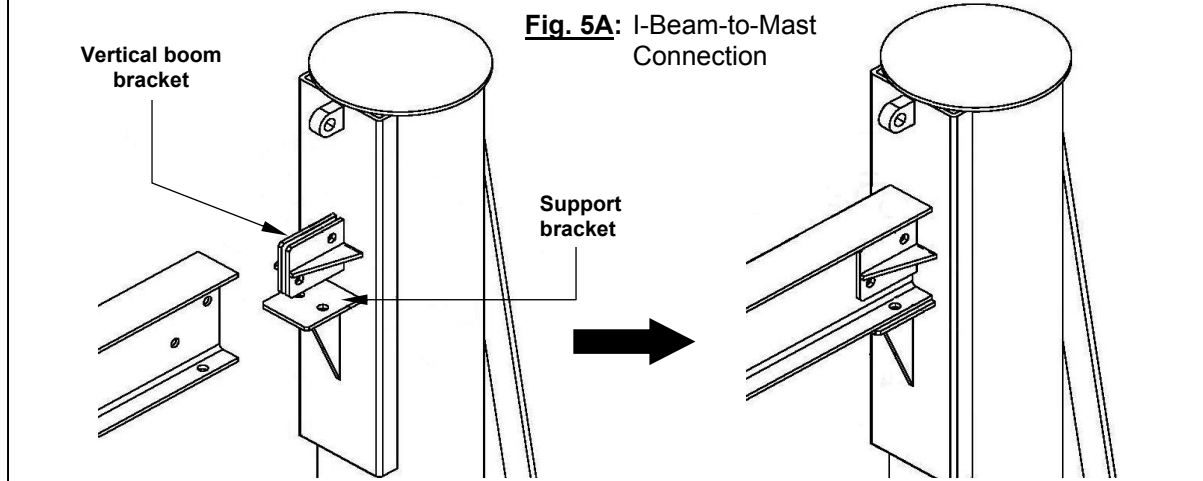
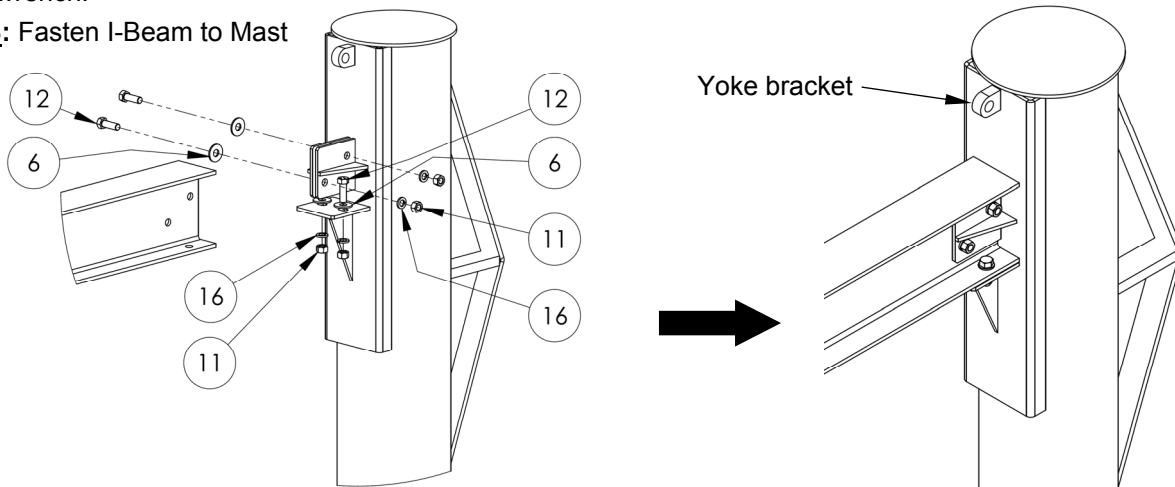

Fig. 5A: I-Beam-to-Mast Connection

Step 2b: Put a 1/2" flat washer (6) on four 1/2" x 1-1/2" hex head bolts (12); then insert the bolts through the corresponding holes. Slide a 1/2" lock washer (16) onto the free end of each bolt and secure each connection with a 1/2" hex nut (11). Finger tighten all nuts and bolts. After completing step 3, tighten bolts to 40 ft-lb with a torque wrench.

Fig. 5B: Fasten I-Beam to Mast



Step 3: Connect a yoke (1) at one end of the tie rod to the yoke bracket (on the mast) with a 3/4" x 2" clevis pin; then secure the connection with a cotter pin. Check beam levelness. Make sure it is level before continuing (e.g. use a forklift to level the beam). Connect the other end of the tie rod to the bracket at the end of the beam in the same manner. Return to step 2b and tighten nuts to 40 ft-lb with a torque wrench.

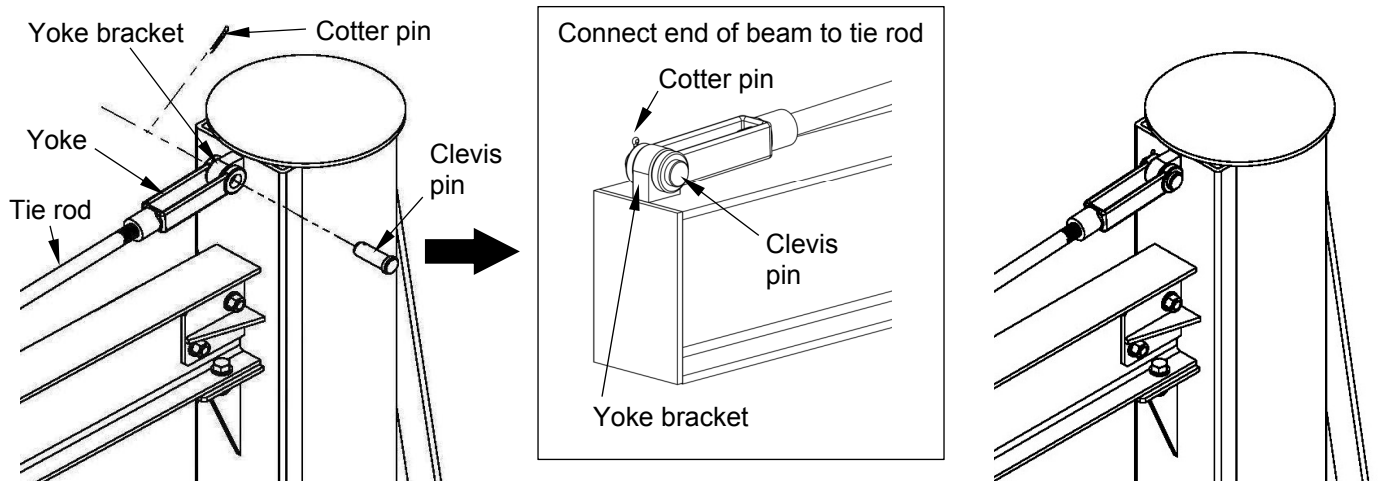

Step 4: Liberally grease the roller bearing (16) located on the bottom of the mast. Lift the Mast-and-Boom assembly with a lifting means of sufficient capacity (at least 1,000lb.) and lower the mast into the socket. Make sure the bearing seats properly in the bearing cup (see Figs. 1, 2 & 3 on p. 4, 5 and 6 respectively).

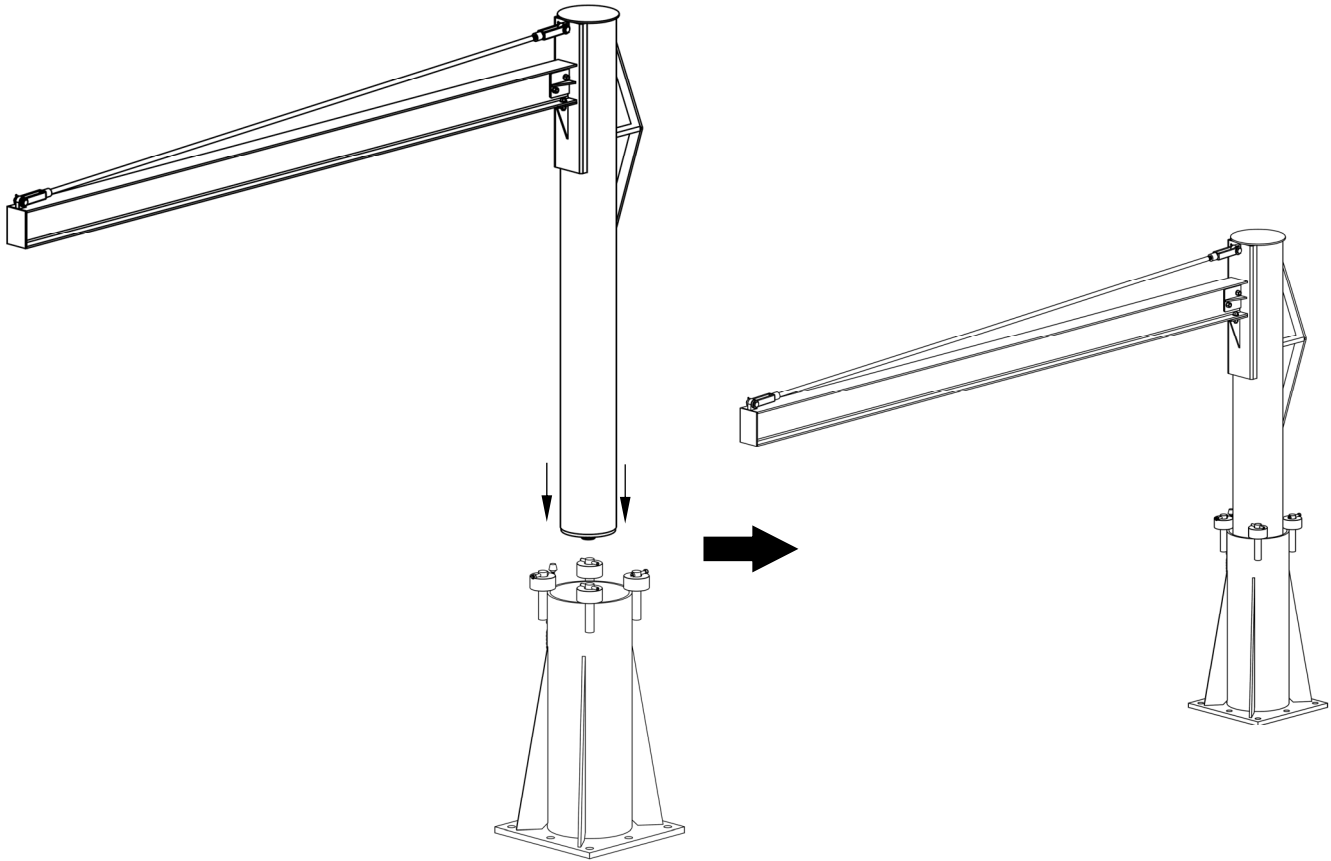

Step 5: Install the roller guard around the mast using $\frac{1}{4}$ " - 20 x $\frac{3}{4}$ " bolts (part no. 13003), $\frac{1}{4}$ " lock washers (33618), and $\frac{1}{4}$ " - 20 hex nuts (part no. 36302) indicated in the diagram below.

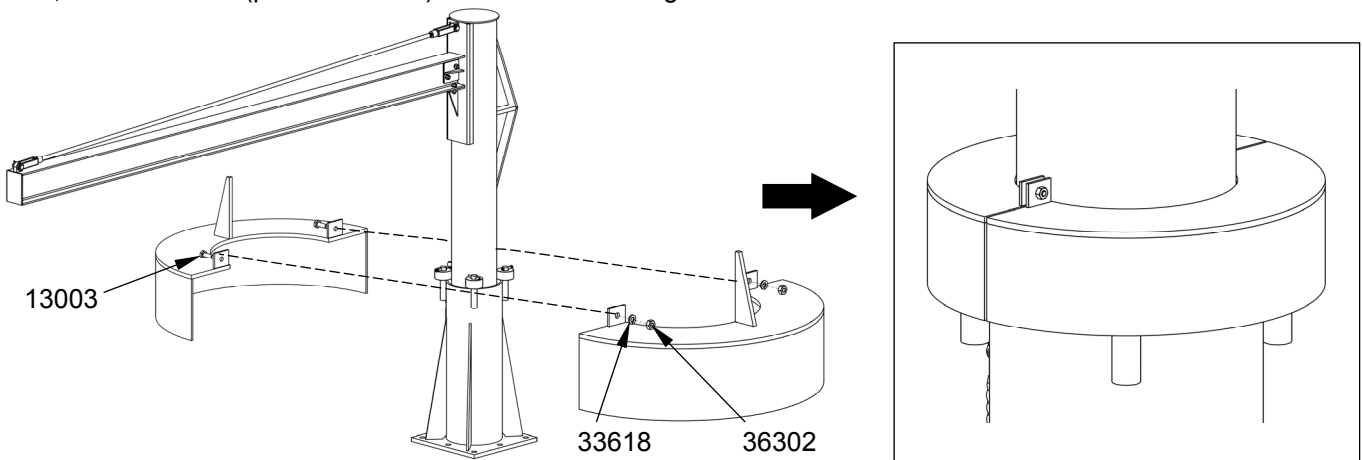

Operation Instructions:

NOTE: Before using the crane for the first time, OSHA regulations require an "Initial Inspection". The substance of this inspection is reproduced on p. 11-12. ALWAYS conduct the "Function Tests" described on p. 3 prior to use.

WARNING Crane operators are responsible for operating the crane in a safe manner. To mitigate the possibility of serious personal injuries or death during operation:

- Only qualified, designated crane operators should use this device. The operating instructions in this manual *supplement* safe crane and hoist operation practices learned during your training program. ALWAYS apply the safe material handling practices learned from your training program (for example, practical operating examination) and conform to OSHA crane operation standards (29 CFR 1910.179).
- All personnel not using the crane should remain outside the operating area during use. Instruct all persons to remain at a safe distance during operation. Be certain no part of any person or object is under any part of the boom (I-beam) or the suspended load at any time and particularly before lowering it.
- Always carefully watch the boom and any load hanging from it while using the crane.
- DO NOT use the crane if: 1) you observe any damage to the base socket or hear unusual noise during operation; 2) if you observe any warping or deformation of the boom, the mast, the load hook or chain (or cable). Notify your supervisor and authorized maintenance personnel if you notice anything unusual.

Proper load lifting:

Always follow the instructions provided with your hoist and trolley!

Position the trolley and hoist directly above the load. Proper load centering requires the operator to position the hoist above the center of the load. Proper positioning is diagrammed below:

Proper load centering beneath hoist and trolley

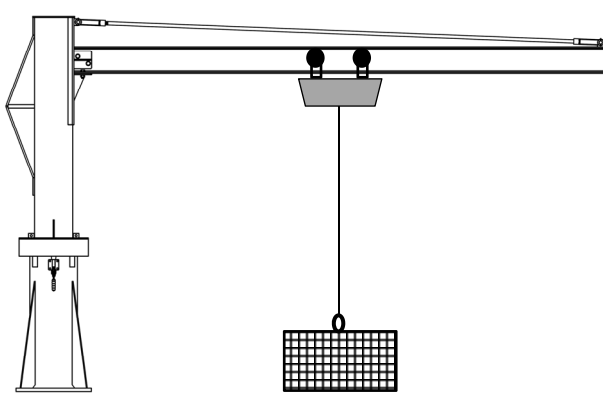

Side view

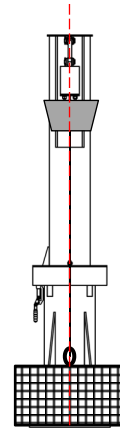

Front view

Hoist cable/chain aligned with centerline (red dashed line)

Improperly positioned loads

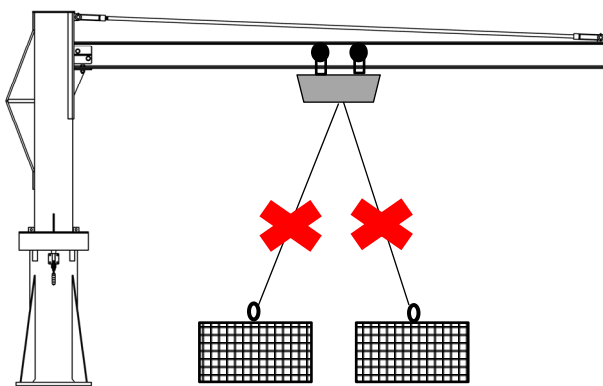

Side view

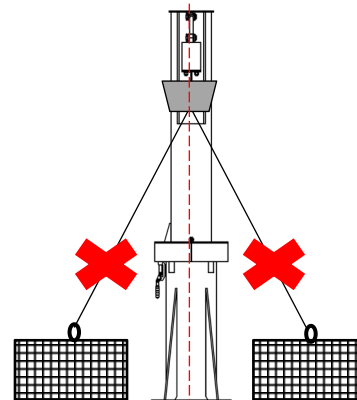

Front view

Hoist cable/chain not aligned with centerline (red dashed line)

When the beam and trolley are properly centered above the load and BEFORE the load is connected to the hoist, lock the crane with the mast clamp (shown below).

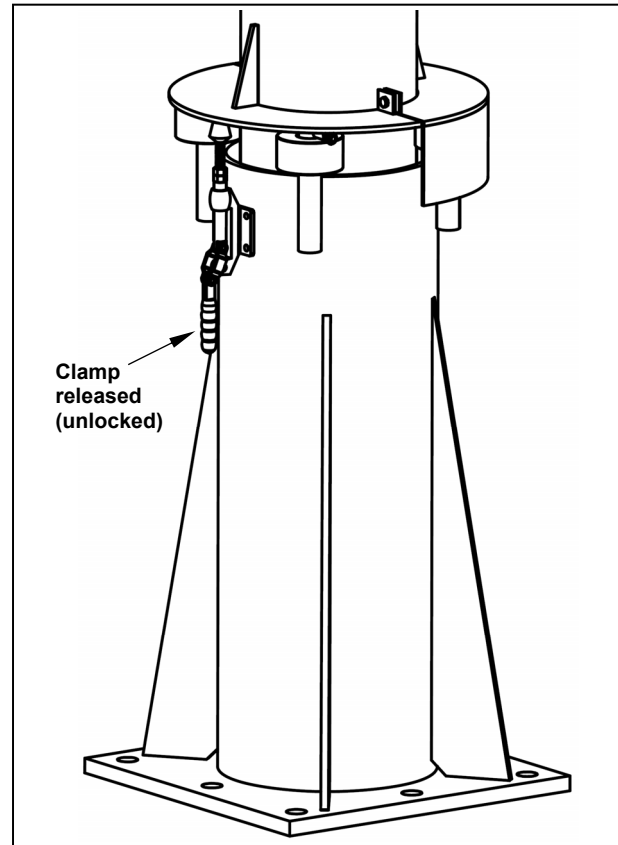
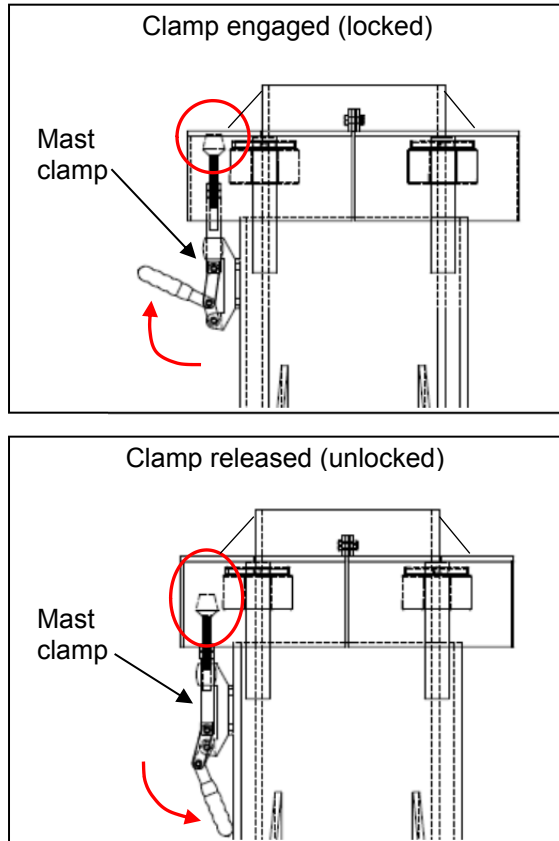

Connect the load to the hoist chain/cable, following the hoist manufacturer's instructions. Then, raise the load only as high as necessary. If the job requires you to move the load to a different location within the crane's serviceable zone, disengage the clamp, and slowly direct the load to the desired location. Once the I-beam and hoist are properly centered above the work location, lower the load until it is fully supported by the ground (or other work surface, e.g. lift table) and disconnect the load from the hoist. Return the crane and hoist to their storage positions and lock the crane with the mast clamp.

Inspections & Maintenance:

Apply Occupational Safety and Health Administration (OSHA) crane inspection procedures (see 29 CFR 1910.179). Inspections are classified according to the intervals at which inspection should be performed. The identity of the components to be inspected and the degree to which those components wear, deteriorate, or malfunction determine how frequently you must inspect the crane. 29 CFR 1910.179(j) describes the various inspections the end user is responsible for performing on this crane:

1. **Initial inspection** — before a new or modified crane may be used for the first time, it must be inspected to insure normal condition. Conduct a "Frequent inspection" as described next.

After the first use, the crane end-user/owner must conduct the following 2 types of inspection:

2. **Frequent inspection** [29 CFR 1910.179(j)(1)(ii)(a)] — Daily to monthly intervals.

The following items shall be inspected for defects at the intervals specifically indicated, including observation *during operation* for any defects which might appear between inspections. All deficiencies such as those listed shall be carefully examined to determine whether they constitute a safety hazard:

- **[Inspect daily]** All functional operating mechanisms (mast, beam, socket, bearings, tie rod, rollers, and mast clamp) for maladjustment interfering with proper operation. Verify that the rollers operate smoothly by turning the crane 4-6 feet in one direction.
- **[Inspect daily (visually); inspect monthly and make a certification record, which includes the date of inspection, the signature of the person who performed the inspection and the serial number (or other identifier) of the hook inspected]** Hooks with deformation or cracks. Immediately discard hooks with cracks or that have a throat opening that is more than 15 percent in excess of normal throat opening, or that are twisted more than 10° from the plane of the unbent hook.

- **[Inspect daily (visually); monthly inspection with a certification record which includes the date of inspection, the signature of the person who performed the inspection and an identifier of the chain which was inspected]** Hoist chains, including end connections, for excessive wear, twist, distorted links interfering with proper function, or stretch beyond hoist manufacturer's recommendations.
- **[Inspect weekly]** All functional operating mechanisms (mast, beam, socket, tie rod, rollers, mast clamp, pins, and yokes, bolts and nuts, including anchor bolts and nuts) for excessive wear.
- **[Inspect weekly]** Rope reeving for noncompliance with hoist manufacturer's recommendations.

3. **Periodic inspection** [29 CFR 1910.179(j)(1)(ii)(b)] — 1 to 12-month intervals.

Complete inspections of the crane shall be performed at intervals depending upon its activity, severity of service, and environment, or as specifically indicated below. Perform all of the requirements described for frequent inspections and the following bulleted items. Carefully examine the crane for any problems such as those listed below to determine whether they constitute a safety hazard:

- Deformed, cracked, or corroded members.
- Loose bolts or rivets.
- Cracked or worn sheaves and drums.
- Worn, cracked or distorted parts such as pins, bearings, rollers, locking and clamping devices.
- Excessive wear on brake system parts, linings, pawls, and ratchets.
- Load, wind, and other indicators over their full range, for any significant inaccuracies.
- Gasoline, diesel, electric, or other power plants for improper performance or noncompliance with applicable safety requirements.
- Excessive wear of chain drive sprockets and excessive chain stretch.
- Electrical apparatus, for signs of pitting or any deterioration of controller contactors, limit switches and pushbutton stations.

Cranes not in regular use: for each of the 3 bullet points below, in addition to the *crane* inspection all rope which has been idle for a period of a month or more due to shutdown or storage of a crane on which it is installed must be given a thorough inspection before it is used. An appointed person, whose approval is required before the rope may be used, must inspect the rope for all types of deterioration. A certification record must be available for inspection. The record must include at least the date of inspection, the signature of the person who performed the inspection and an identifier for the rope inspected.

- A crane which has been idle for a period of 1 month or more, but less than 6 months, shall undergo a "Frequent inspection" before being returned to service.
- A crane which has been idle for a period of over 6 months shall be given a "Complete inspection" before placing in service.
- Standby cranes shall be given a "Frequent inspection" at least semi-annually (twice per year; 1 inspection each 6 months).

Labeling diagram:

Only use the dumper if it is labeled as diagrammed below. ALL labels must be readable and undamaged. Replace all damaged/unreadable labels.

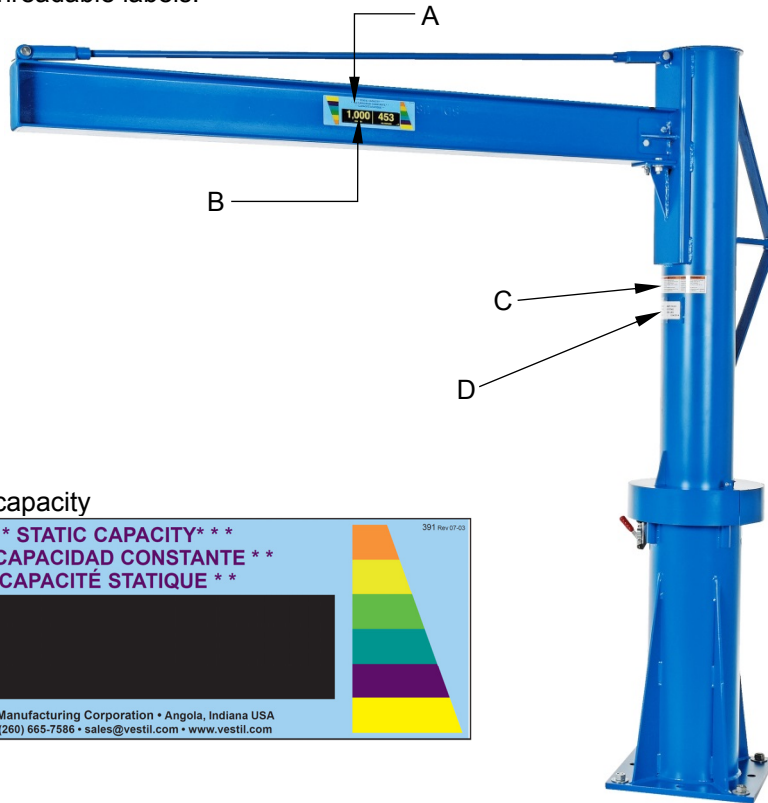

A: Label 391 – Crane capacity



B: Label 560 (applied to blacked rectangle of label 391) – Crane capacity



C: Label 586 – Hazards associated with crane use

⚠ WARNING	⚠ ADVERTENCIA	⚠ AVERTISSEMENT
<ul style="list-style-type: none"> • DO NOT exceed rated capacity • LOWER LOAD before moving to avoid load swing • NEVER STAND under, beside or in front of load • USE on hard level surface • INSPECT connections before using • READ manual before use 	<ul style="list-style-type: none"> • No exceda la capacidad tasada • Descienda la carga antes de mover para evitar que la carga se balancee • Nunca se situe debajo, al lado o delante de la carga • Use en una superficie a nivel dura • Inspeccione las conexiones antes del uso • Lea el manual antes del uso 	<ul style="list-style-type: none"> • NE PAS DÉPASSER la capacité nominale • DESCENDRE la charge avant de la transporter pour éviter la giration • JAMAIS vous mettre sous, à côté de ou devant une charge • UTILISER sur un sol plat et dur • INSPECTER les connexions avant utilisation • LIRE le guide avant utilisation

586 rev 1210

D: Label 287 – Product data label.

MODEL/MODÉLO/MODÈLE _____

STATIC CAPACITY (evenly distributed) _____ lbs.

LA CAPACIDAD CONSTANTE (distribuida uniformemente) _____ kgs.

CAPACITÉ STATIQUE (distribuée régulièrement) _____ kgs.

SERIAL/SERIE/SÉRIE _____

287 REV 0812

LIMITED WARRANTY

Vestil Manufacturing Corporation (“Vestil”) warrants product to be free of defects in material and workmanship during the warranty period. *Our warranty obligation is to provide a replacement for a defective original part if the part is covered by the warranty, after we receive a proper request from the warrantee (you) for warranty service.*

Who may request service?

Only a warrantee may request service. *You are a warrantee if* you purchased the product from Vestil or from an authorized distributor AND Vestil has been fully paid.

What is an “original part”?

An original part is a part used to make the product as shipped to the warrantee.

What is a “proper request”?

A request for warranty service is proper if Vestil receives: 1) a photocopy of the Customer Invoice that displays the shipping date; AND 2) a written request for warranty service including your name and phone number. Send requests by any of the following methods:

<u>Mail</u>	<u>Fax</u>	<u>Email</u>
Vestil Manufacturing Corporation 2999 North Wayne Street, PO Box 507 Angola, IN 46703	(260) 665-1339 <u>Phone</u> (260) 665-7586	sales@vestil.com

In the written request, list the parts believed to be defective and include the address where replacements should be delivered.

What is covered under the warranty?

After Vestil receives your request for warranty service, an authorized representative will contact you to determine whether your claim is covered by the warranty. Before providing warranty service, Vestil may require you to send the entire product, or just the defective part or parts, to its facility in Angola, IN. The warranty covers defects in the following original dynamic components: motors, hydraulic pumps, electronic controllers, switches and cylinders. It also covers defects in original parts that wear under normal usage conditions (“wearing parts”), such as bearings, hoses, wheels, seals, brushes, and batteries.

How long is the warranty period?

The warranty period for original dynamic components is 90 days. For wearing parts, the warranty period is 90 days. The warranty periods begin on the date when Vestil ships the product to the warrantee. If the product was purchased from an authorized distributor, the periods begin when the distributor ships the product. Vestil may, at its sole discretion, extend the warranty periods for products shipped from authorized distributors by *up to* 30 days to account for shipping time.

If a defective part is covered by the warranty, what will Vestil do to correct the problem?

Vestil will provide an appropriate replacement for any covered part. An authorized representative of Vestil will contact you to discuss your claim.

What is not covered by the warranty?

1. Labor;
2. Freight;
3. Occurrence of any of the following, which automatically voids the warranty:
 - Product misuse;
 - Negligent operation or repair;
 - Corrosion or use in corrosive conditions;
 - Inadequate or improper maintenance;
 - Damage sustained during shipping;
 - Accidents involving the product;
 - Unauthorized modifications: DO NOT modify the product IN ANY WAY without first receiving written authorization from Vestil. Modification(s) might make the product unsafe to use or might cause excessive and/or abnormal wear.

Do any other warranties apply to the product?

Vestil Manufacturing Corp. makes no other express warranties. All implied warranties are disclaimed to the extent allowed by law. Any implied warranty not disclaimed is limited in scope to the terms of this Limited Warranty.

