

ALUMINUM WHEEL CHOCK W/HANDLE- EALUM-7-H

APPROX WEIGHT: 9.98 lbs.
DOES NOT INCLUDE WEIGHT OF POWER OR PACKAGING!!!

*** ANY ADDITIONS, DELETIONS, OR OMISSIONS MUST BE CORRECTED ON THIS DRAWING AS THIS DRAWING WILL BE CONSIDERED ALL INCLUSIVE ***
ALL GRAPHICS PROVIDED ARE FOR REFERENCE ONLY. IF CERTAIN DIMENSIONS ARE CRITICAL PLEASE VERIFY THOSE DIMENSIONS WITH YOUR SALESPERSON

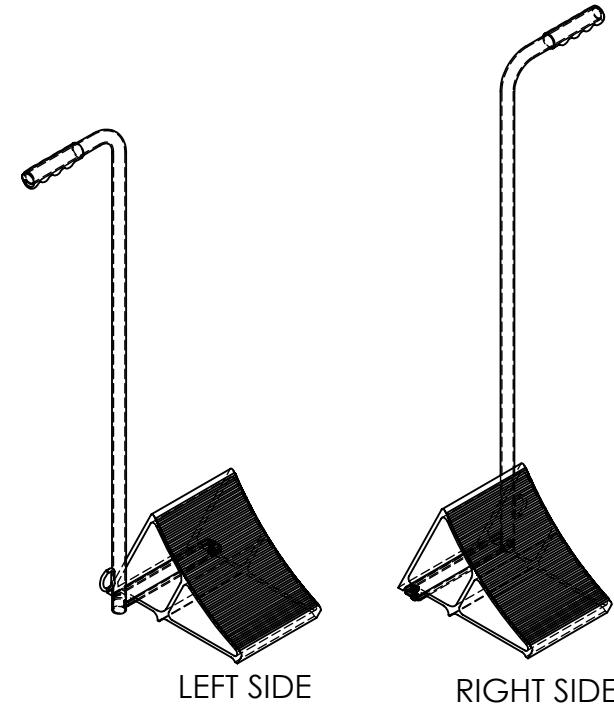
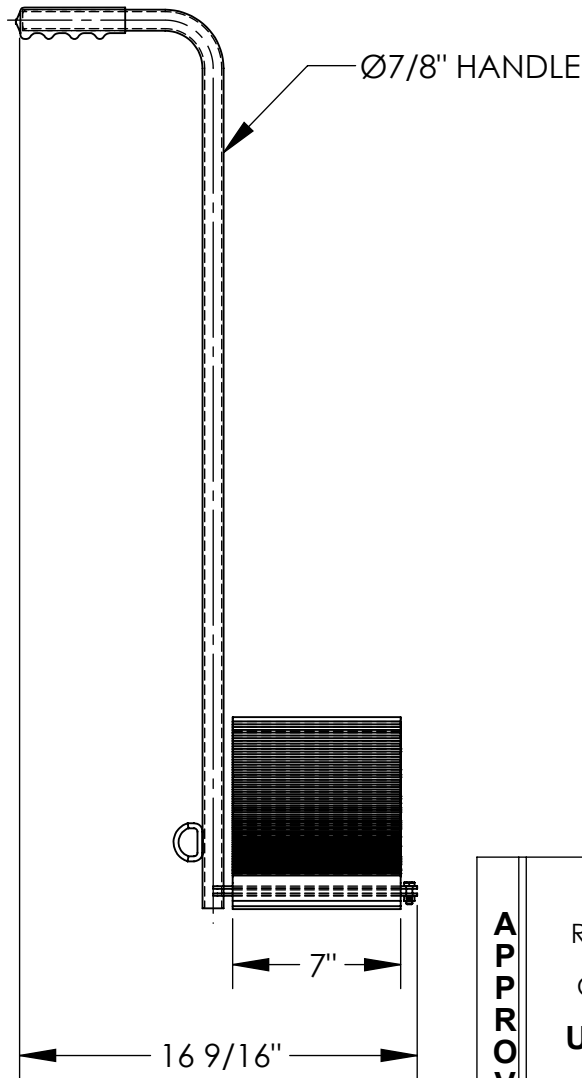
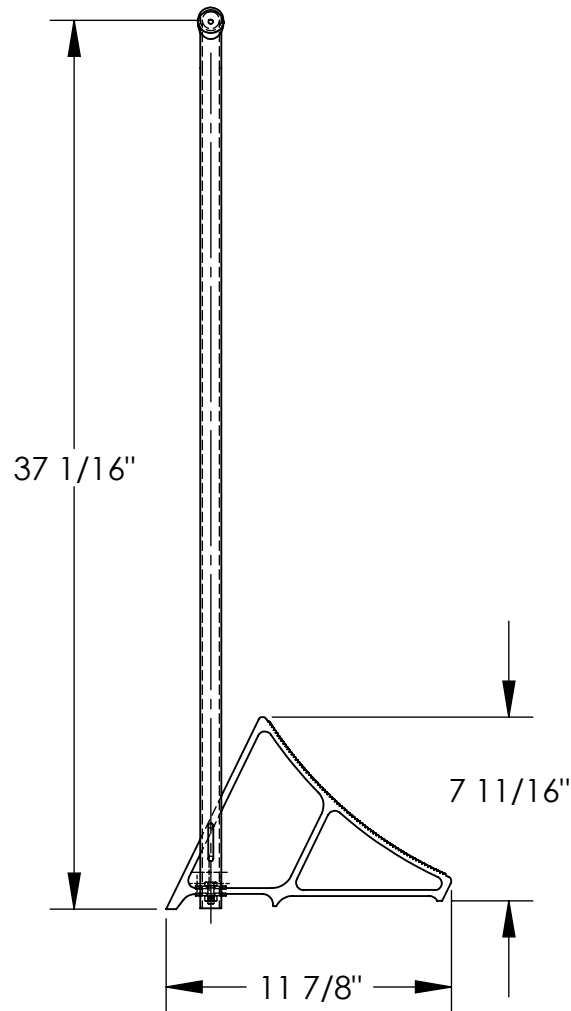

DIMENSION TOLERANCE ± 1/4"

STANDARD FEATURES

MODEL NUMBER IS: EALUM-7-H
OVERALL WIDTH IS: 17 1/16"
CHOCK WIDTH IS: 7"
OVERALL LENGTH IS: 11 7/8"
CHOCK LENGTH IS: 11 7/8"
OVERALL HEIGHT IS: 37 9/16"
CHOCK HEIGHT IS: 7 11/16"
SHIPS KNOCKED DOWN
HANDLE IS REVERSIBLE
HANDLE IS TOUGH BAKED IN
POWDER COAT YELLOW FINISH

SPECIAL FEATURES
NONE

APPROVAL

I, THE UNDERSIGNED, AGREE THAT THE PRODUCT AS REPRESENTED SATISFIES DESIGN AND DIMENSION REQUIREMENTS. I ALSO ACKNOWLEDGE MY DUTY TO CONFIRM PRODUCT AND INSTALLATION COMPLIANCE WITH ALL APPLICABLE FEDERAL, STATE AND LOCAL REGULATIONS AND STANDARDS.
UNITS REQUIRING APPROVAL DRAWINGS OR MODIFIED ARE NON-RETURNABLE
 As drawn As marked

Signed: _____ Date: _____

Printed Name: _____

LEAD TIME WILL START UPON RECEIPT OF SIGNED APPROVAL DRAWING

DISTRIBUTOR'S NAME:		P.O.#
VESTIL MANUFACTURING		X
DRAWN BY: RPS		W.O.#
DATE: 10/25/2012		X
REFERENCE: X	SCALE: 1:8	SALES: X
QUOTED LEAD TIME: X	QUOTE #	FILE NAME:
	X	23-007-235