



**Vestil Manufacturing Corp.**  
 2999 North Wayne Street, P.O. Box 507, Angola, IN 46703  
 Telephone: (260) 665-7586 -or- Toll Free (800) 348-0868  
 Fax: (260) 665-1339  
 Web: [www.vestilmfg.com](http://www.vestilmfg.com) e-mail: [info@vestil.com](mailto:info@vestil.com)

## SPG-Series Self-Closing Guardrail Gates

### Assembly and Installation Manual



**Receiving instructions:**

After delivery, remove the packaging from the product. Inspect the product closely to determine whether it sustained damage during transport. If damage is discovered, immediately record a complete description of the damage on the bill of lading. If the product is undamaged, discard the packaging.

**Note:**

The end-user is solely responsible for confirming that product design complies with all laws, regulations, codes, and mandatory standards applied where the product is used.

**Table of Contents**

Assembly & Installation.....	2 – 3
SPG-26 Exploded Parts Diagram and Bill of Materials.....	4
SPG-40 Exploded Parts Diagram and Bill of Materials.....	5
Limited Warranty.....	6

# Assembly & Installation

## Front view of gate assembly

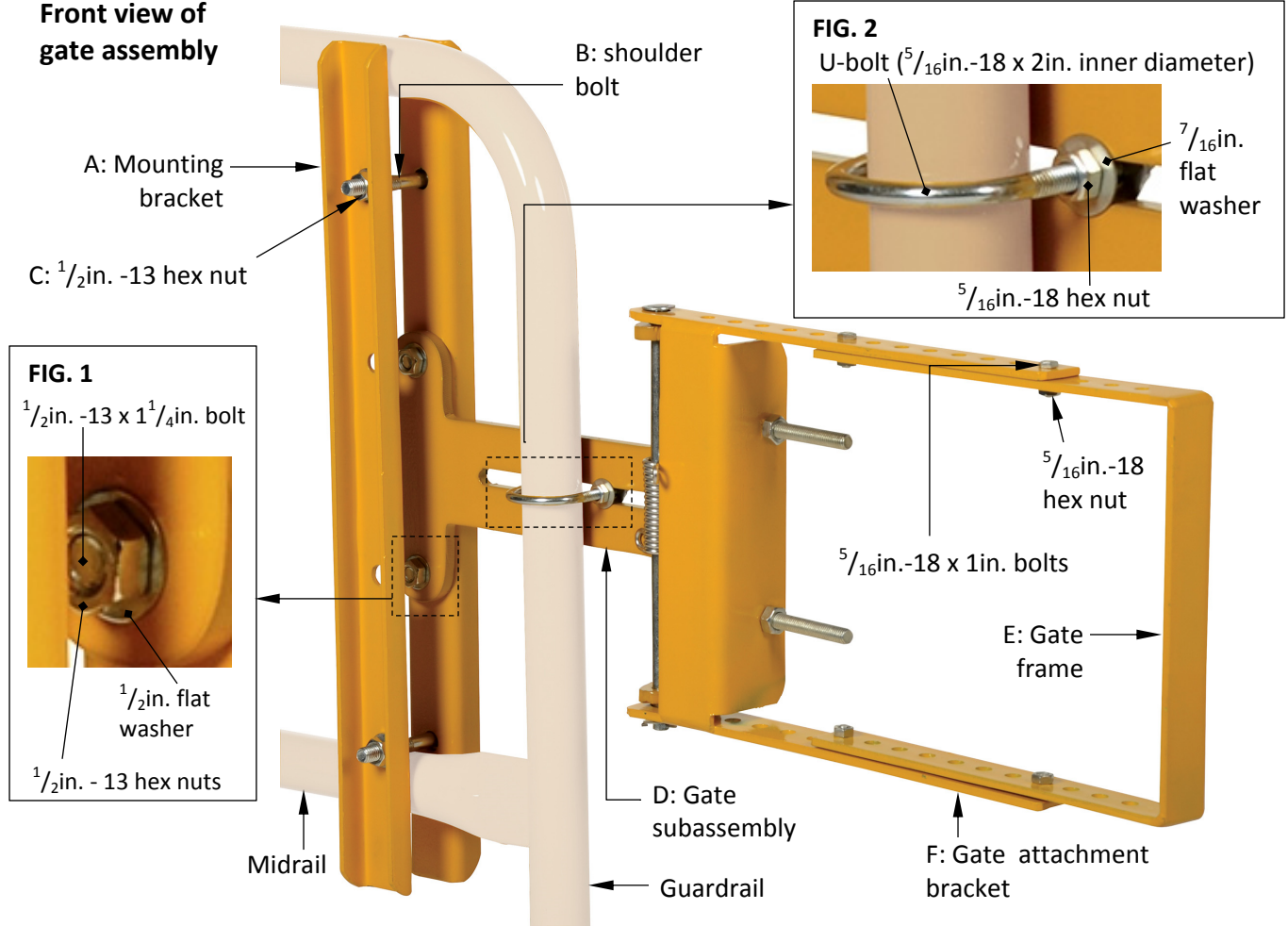

## Rear view of gate assembly

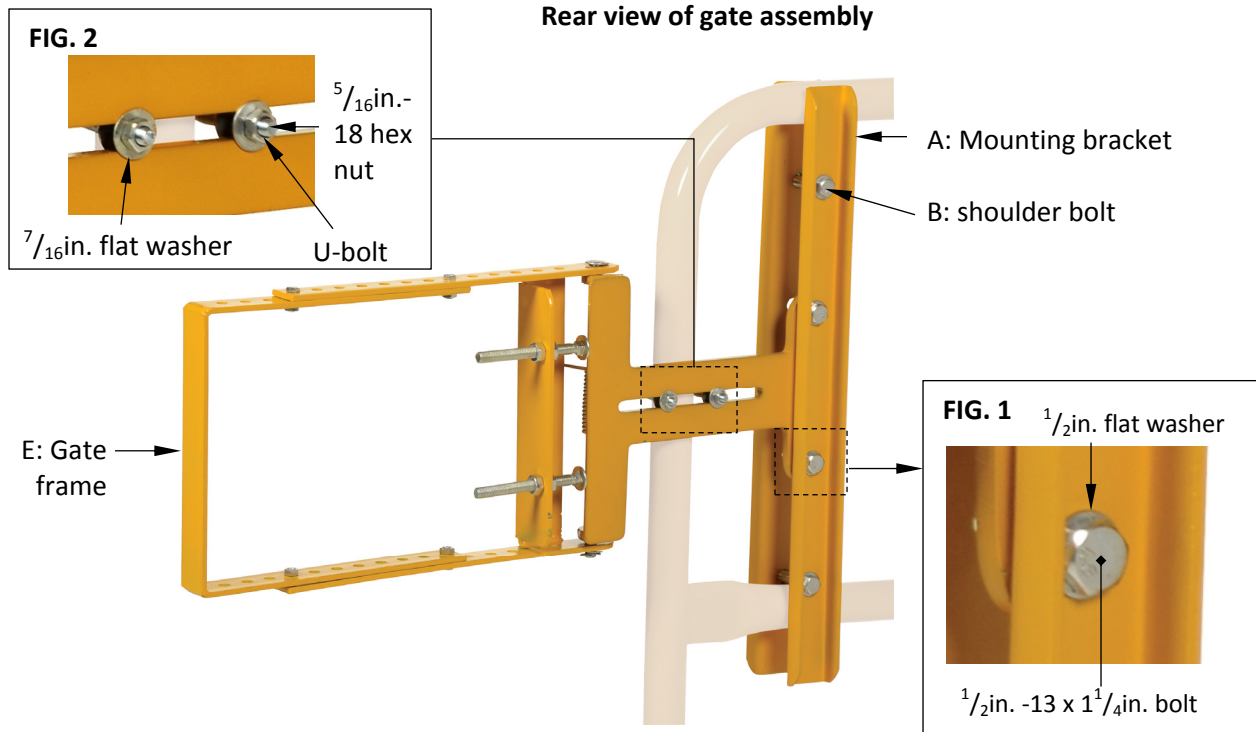

Follow the steps outlined below to assemble your SPG-series gate. Letters in parentheses () correspond to parts identified in the diagrams on p. 1.

- 1) Attach mounting brackets to the guardrail.
  - a. Position both of the mounting brackets (A) so that the bottom bolt hole is just above the midrail; then
  - b. Insert a  $\frac{1}{2}$ in. -13 x 3in. shoulder bolt (B) through the top bolt hole in the brackets;
  - c. Insert another shoulder bolt through the bottom hole in the brackets {NOTE: The bolt will contact the top of the midrail}; and then
  - d. Secure each bolt with a  $\frac{1}{2}$ in. -13 hex nut (C).
- 2) Fasten the gate subassembly to the mounting brackets as shown in FIG. 1.
  - a. Align the bolt holes in the gate subassembly (D) with the 2 middle holes in one of the mounting brackets (A).
  - b. Put a  $\frac{1}{2}$ in. flat washer onto two  $\frac{1}{2}$ in. -13 x  $1\frac{1}{4}$ in. bolts; then
  - c. Insert the bolts through the mounting bracket and subassembly and secure them with  $\frac{1}{2}$ in. flat washers and  $\frac{1}{2}$ in. -13 hex nuts.
- 3) Fasten the gate subassembly (D) to the guardrail as shown in FIG. 2.
  - a. Put a  $\frac{7}{16}$ in. USS flat washer on both ends of the  $\frac{5}{16}$ in. -18 x 2in. U-bolt; then
  - b. Feed the ends of the U-bolt through the slot in the gate subassembly; and
  - c. Secure the ends of the U-bolt with  $\frac{5}{16}$ in. flat washers,  $\frac{5}{16}$ in. lock washers, and  $\frac{5}{16}$ in. -18 hex nuts.
- 4) Attach the gate frame (E) to the gate attachment brackets (F).
 

[NOTE: SPG-40 models include parts called extender brackets.]

  - a. Determine how long the gate needs to be. If you have an SPG-40 series gate, determine if extender brackets are needed. If brackets are not necessary, skip part b below.
  - b. [SPG-40 models only] Attach extender brackets to the attachment brackets with  $\frac{5}{16}$  in. – 18 UNC x 1 in. and  $\frac{5}{16}$  in. – 18 hex nuts.

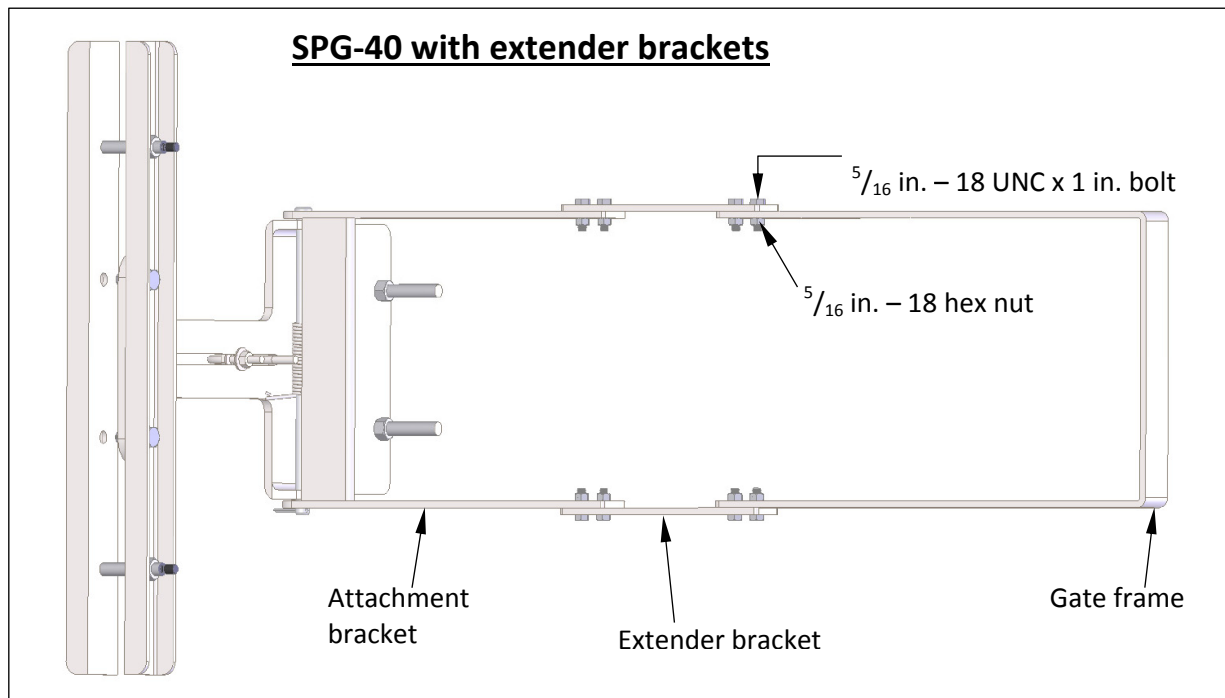

- c. Fasten the gate frame to the length attachment brackets using  $\frac{5}{16}$ in.-18 x 1in. bolts and  $\frac{5}{16}$ in.-18 hex nuts. To properly stabilize the structure, insert the bolts through the bolt holes at the ends of the gate frame and through the bolt holes at the ends of the length attachment brackets.

# SPG-26 exploded parts diagram:

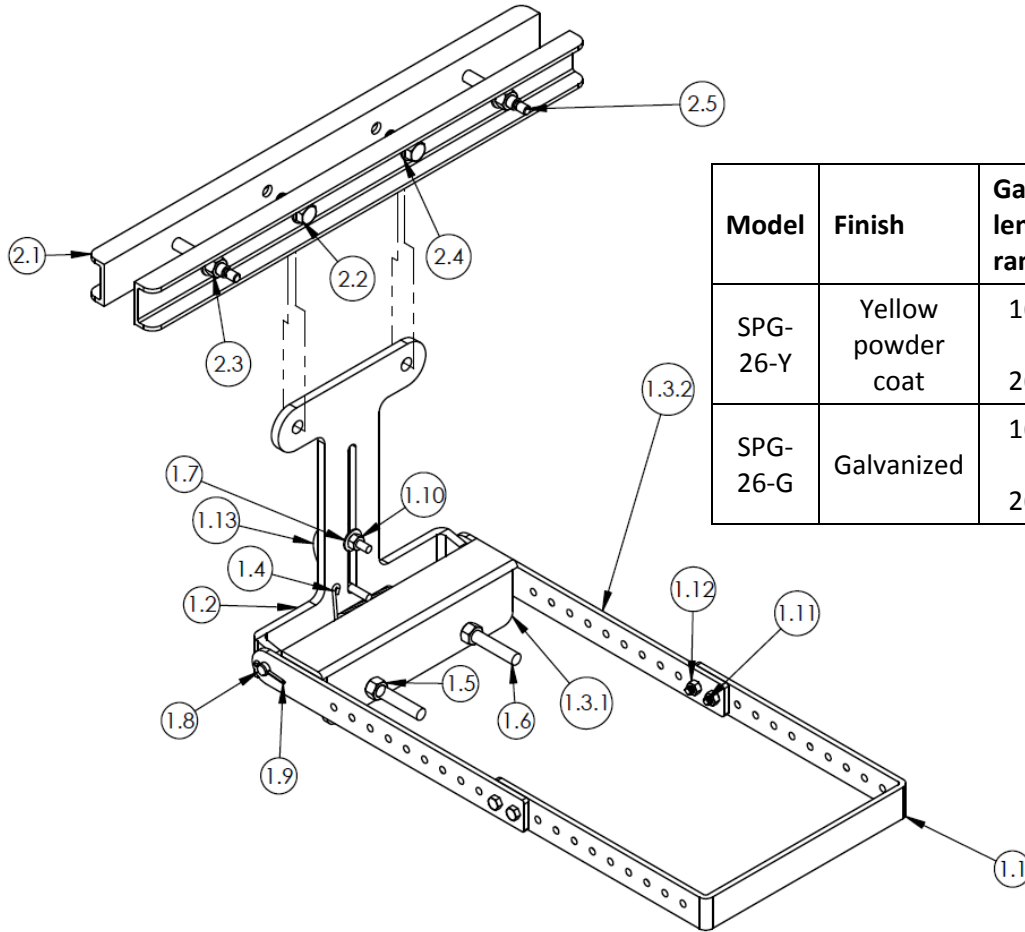

Model	Finish	Gate length range	Height	Net weight
SPG-26-Y	Yellow powder coat	16in. to 26in.	12in.	30 lb.
SPG-26-G	Galvanized	16in. to 26in.	12in.	30 lb.

Item no.	Part no.	Description	Quantity
1	23-514-118	Frame, gate subassembly	1
1.1	23-014-178	Frame, gate	1
1.2	23-016-114	Bracket, rail mounting	1
1.3	23-516-010	Frame, adjustable length bracket	1
1.3.1	23-016-134	Bracket, formed plate	1
1.3.2	23-016-135	Bracket, gate attachment	2
1.4	23-146-003	Spring	1
1.5	36109	$\frac{1}{2}$ in. - 13 UNC hex nut	4
1.6	21521	$\frac{1}{2}$ in. - 13 x $4\frac{1}{2}$ in. carriage bolt	2
1.7	33009	$\frac{7}{16}$ in. USS flat washer	2
1.8	23-112-014	$\frac{1}{2}$ in. clevis pin	1
1.9	65078	Cotter pin, $\frac{1}{8}$ in. x $1\frac{1}{2}$ in., zinc-plated	1
1.10	36103	$\frac{5}{16}$ in. - 18 UNC, plain hex nut	2
1.11	11055	HHCS #2 zinc-plated $\frac{5}{16}$ in. - 18 UNC x 1 in.	4
1.12	36104	$\frac{5}{16}$ in. - 18 zinc-plated hex nut	4
1.13	42030	$\frac{5}{16}$ in. - 18 UNC x 2 in. (inside diameter) U-bolt	1
2	23-514-120	Frame, rail mount subassembly	1
2.1	23-014-189	Frame, rail mount, channel	2
2.2	11207	$\frac{1}{2}$ in. - 13 UNC $1\frac{1}{4}$ in., zinc-plated bolt	2
2.3	36109	$\frac{1}{2}$ in. - 13 UNC hex nut	4
2.4	33011	$\frac{1}{2}$ in. USS flat washer	8
2.5	26358	$\frac{3}{8}$ in. - 16 SHSB, $\frac{1}{2}$ in. x 3 in. shoulder bolt	2

# SPG-40 exploded parts diagram:

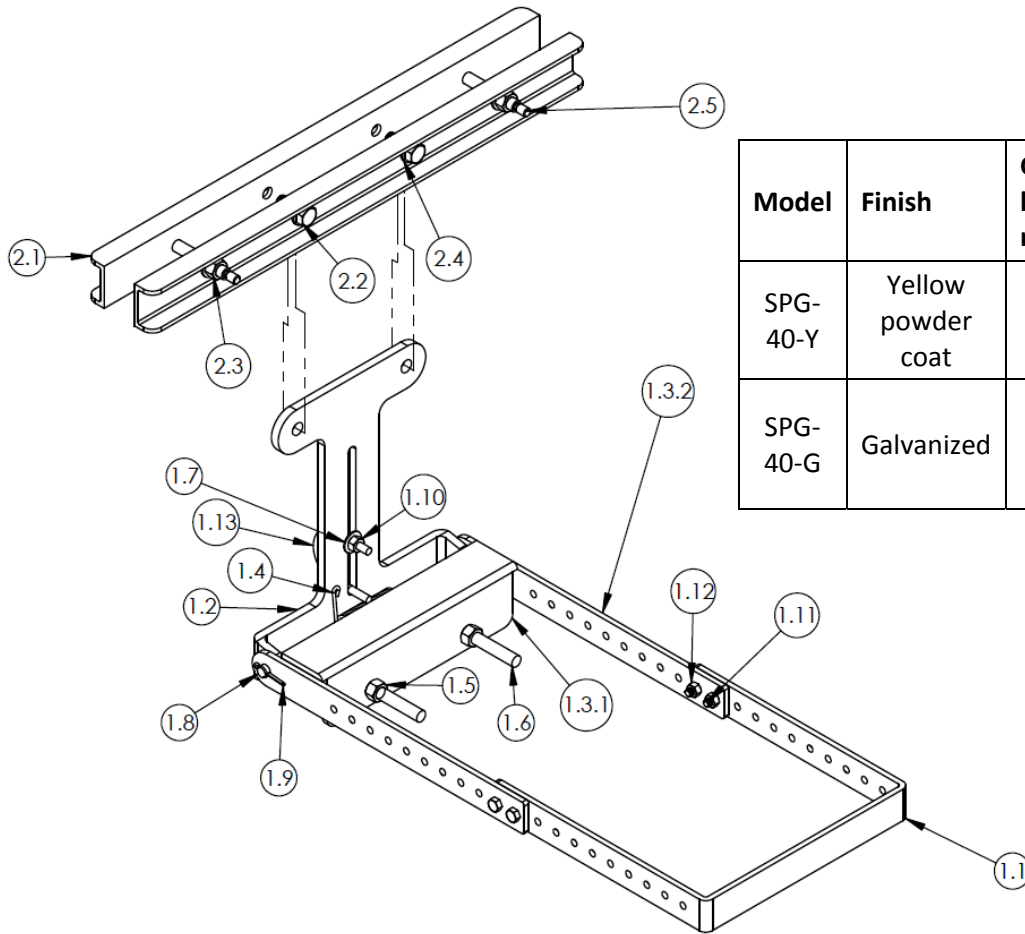

Model	Finish	Gate length range	Height	Net weight
SPG-40-Y	Yellow powder coat	24in. to 40in.	12in.	35 lb.
SPG-40-G	Galvanized	24in. to 40in.	12in.	35 lb.

Item no.	Part no.	Description	Quantity
1	23-514-119	Frame, gate subassembly	1
1.1	23-014-178	Frame, gate	1
1.2	23-516-010	Frame, adjustable length bracket	1
1.2.1	23-016-134	Bracket, formed plate	1
1.2.2	23-016-135	Bracket, gate attachment	2
1.3	23-146-003	Spring	1
1.4	36109	1/2 in. - 13 UNC hex nut	4
1.5	21521	1/2 in. - 13 x 4 1/2 in. carriage bolt	2
1.6	33009	7/16 in. USS flat washer	2
1.7	23-112-014	1/2 in. clevis pin	1
1.8	65078	Cotter pin, 1/8 in. x 1 1/2 in., zinc-plated	1
1.9	36103	5/16 in. - 18 UNC, plain hex nut	2
1.10	23-014-179	Frame, gate	1
1.11	23-016-133	Bracket, gate extender	2
1.12	11055	HHCS #2 zinc-plated 5/16 in. - 18 UNC x 1 in.	4
1.13	36104	5/16 in. - 18 zinc-plated hex nut	4
1.14	42030	5/16 in. - 18 UNC x 2 in. (inside diameter) U-bolt	1
2	23-514-120	Frame, rail mount subassembly	1
2.1	23-014-189	Frame, rail mount, channel	2
2.2	11207	1/2 in. - 13 UNC 1 1/4 in., zinc-plated bolt	2
2.3	36109	1/2 in. - 13 UNC hex nut	4
2.4	33011	1/2 in. USS flat washer	8
2.5	26358	3/8 in. - 16 SHSB, 1/2 in. x 3 in. shoulder bolt	2

## LIMITED WARRANTY

Vestil Manufacturing Corporation (“Vestil”) warrants this product to be free of defects in material and workmanship during the warranty period. *Our warranty obligation is to provide a replacement for a defective original part if the part is covered by the warranty, after we receive a proper request from the warrantee (you) for warranty service.*

### Who may request service?

Only a warrantee may request service. *You are a warrantee if you purchased the product from Vestil or from an authorized distributor AND Vestil has been fully paid.*

### What is an “original part”?

An original part is a part used to make the product as shipped to the warrantee.

### What is a “proper request”?

A request for warranty service is proper if Vestil receives: 1) a photocopy of the Customer Invoice that displays the shipping date; AND 2) a written request for warranty service including your name and phone number. Send requests by any of the following methods:

<u>Mail</u>	<u>Fax</u>	<u>Email</u>
Vestil Manufacturing Corporation 2999 North Wayne Street, PO Box 507 Angola, IN 46703	(260) 665-1339 <u>Phone</u> (260) 665-7586	sales@vestil.com

In the written request, list the parts believed to be defective and include the address where replacements should be delivered.

### What is covered under the warranty?

After Vestil receives your request for warranty service, an authorized representative will contact you to determine whether your claim is covered by the warranty. Before providing warranty service, Vestil may require you to send the entire product, or just the defective part or parts, to its facility in Angola, IN. The warranty covers defects in the following original dynamic components: motors, hydraulic pumps, electronic controllers, switches and cylinders. It also covers defects in original parts that wear under normal usage conditions (“wearing parts”), such as bearings, hoses, wheels, seals, brushes, and batteries.

### How long is the warranty period?

The warranty period for original components is 15 days. The warranty period begins on the date when Vestil ships the product to the warrantee. If the product was purchased from an authorized distributor, the period begins when the distributor ships the product. Vestil may extend the warranty period for products shipped from authorized distributors by *up to 30 days* to the duration necessary to account for shipping time.

### If a defective part is covered by the warranty, what will Vestil do to correct the problem?

Vestil will provide an appropriate replacement for any *covered* part. An authorized representative of Vestil will contact you to discuss your claim.

### What is not covered by the warranty?

1. Labor;
2. Freight;
3. Occurrence of any of the following, which automatically voids the warranty:
  - Product misuse;
  - Negligent operation or repair;
  - Corrosion or use in corrosive conditions;
  - Inadequate or improper maintenance;
  - Damage sustained during shipping;
  - Accidents involving the product;
  - Unauthorized modifications: DO NOT modify the product IN ANY WAY without first receiving written authorization from Vestil. Modification(s) might make the product unsafe to use or might cause excessive and/or abnormal wear.

### Do any other warranties apply to the product?

Vestil Manufacturing Corp. makes no other express warranties. All implied warranties are disclaimed to the extent allowed by law. Any implied warranty not disclaimed is limited in scope to the terms of this Limited Warranty.

