



The Ultimate in Fall Protection

Instructions for the following series products:

Sayline™ Multi-Span Wire Rope Horizontal Lifeline

(See inside back page for specific model numbers.)

User Instruction Manual Sayline™ Multi-span Wire Rope Horizontal Lifeline

This manual is intended to meet the Manufacturer's Instructions requirement of applicable standards defined in Section 1.2 and should be used as part of an employee training program as required by the identified agencies.

WARNING: This product is part of a fall protection system. The users must read and follow the manufacturer's instructions for each component of the system. These instructions must be provided to the users of this equipment. The users must read and understand these instructions before using this equipment. Manufacturer's instructions must be followed for proper use and maintenance of this product. Alterations or misuse of this product, or failure to follow instructions, may result in serious injury or death.

IMPORTANT: If you have questions on the use, care, or suitability of this equipment for your application, contact DBI/SALA.

Figure 1 - Typical Sayline™ Multi-span Wire Rope Horizontal Lifeline System

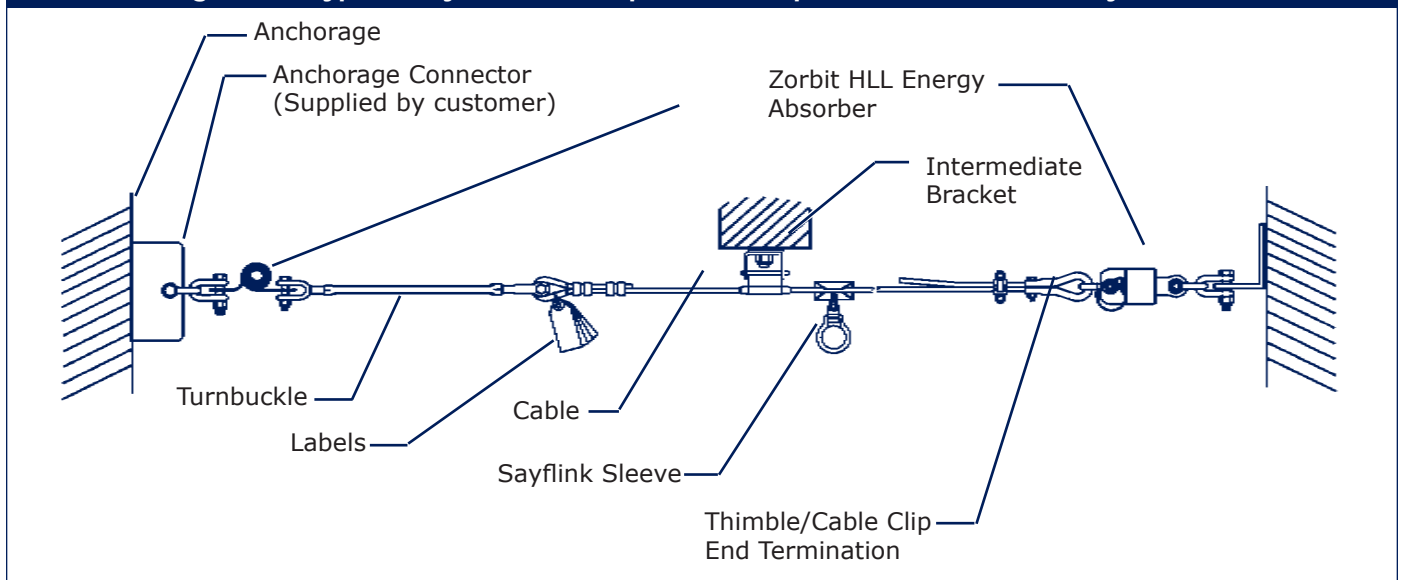

1.0 APPLICATION

1.1 PURPOSE: The Sayline Multi-span Wire Rope Horizontal Lifeline System is designed for use as an anchoring means for one or two personal fall arrest system (PFAS) or fall restraint system. Use the Sayline Horizontal Lifeline (HLL) where horizontal mobility and fall protection is required. The Sayline Horizontal Lifeline may not be used for fall protection of material or equipment.

1.2 LIMITATIONS: The following limits apply to the installation and use of Sayline Multi-span Wire Rope Horizontal Lifeline System. Other limitations may apply:

IMPORTANT: OSHA regulations state that horizontal lifelines shall be installed and used under the supervision of a qualified person (see below for definition) as part of a complete personal fall arrest system that maintains a safety factor of at least two.

Qualified Person: An individual with a recognized degree or professional certificate, and extensive knowledge and experience in the subject field, who is capable of design, analysis, evaluation, and specification in the subject work, project, or product. Refer to OSHA 1910.66, 1926.32, and 1926.502.

- A. **HORIZONTAL LIFELINE SPAN:** The maximum horizontal lifeline total length is 180 ft. (55 m) with a Zorbit HLL energy absorber installed on each end of the system. See Figure 1. Systems that are more than 30 ft. (9 m) in length must include an intermediate bracket for every 30 ft. span (9 m). The span length must be reduced when clearance is limited. See section 3.3 for clearance information.
- B. **ANCHORAGES:** The Sayline horizontal lifeline must be installed on anchorages that meet the requirements specified in section 2.5.
- C. **SYSTEM CAPACITY:** The maximum capacity of the Sayline horizontal lifeline is two persons. The maximum weight of each person, including tools and clothing, is 310 lbs (141 kg).
- D. **CONNECTING SUBSYSTEM:** Each person's connecting subsystem must limit fall arrest forces to 900 lbs. (4 kN) or less. See section 2.6.
- E. **FREE FALL:** Rig and use the personal fall arrest system such that the maximum potential free fall does not exceed government regulatory and subsystem manufacturer's requirements. The personal fall arrest system must be rigged to limit free falls to six feet or less when using an energy absorbing lanyard, or such that the SRL is overhead and without slack, according to OSHA requirements. See section 3.0 and subsystem manufacturer's instructions for more information.
- F. **SWING FALLS:** See Figure 2. Swing falls occur when the anchorage point is not directly overhead. The force of striking an object in a swing fall may cause serious injury or death. Minimize swing falls by working as directly below the anchorage point as possible. Do not permit a swing fall if injury could occur. Swing falls will significantly increase the clearance required when a self retracting lifeline or other variable length connecting subsystem is used. If a swing fall situation exists in your application, contact DBI/SALA before proceeding.
- G. **FALL CLEARANCE:** There must be sufficient clearance below the worker to arrest a fall before striking the lower level or obstruction. See section 3.3 for required clearance information.
- H. **BODY SUPPORT:** Sayline Multi-span Wire Rope Horizontal Lifelines must only be used with personal fall arrest systems incorporating a full body harness.
- I. **PHYSICAL AND ENVIRONMENTAL HAZARDS:** Use of this equipment in areas with physical or environmental hazards may require additional precautions to reduce the possibility of injury to the user or damage to the equipment. Hazards may include, but are not limited to; heat, chemicals, corrosive environments, high voltage power lines, gases, moving machinery, and sharp edges. Contact DBI/SALA if you have questions about using this equipment where physical or environmental hazards exist.
- J. **TRAINING:** This equipment must be installed and used by persons trained in the correct application and use of this equipment. See section 5.0.

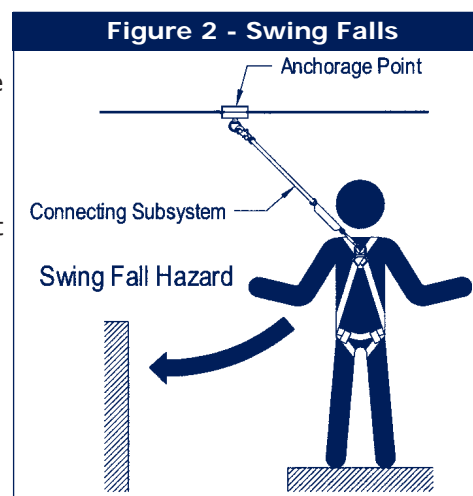

1.3 **APPLICABLE STANDARDS:** Refer to national standards, including ANSI Z359.1-1992, and local, state, and federal (OSHA 1910.66 and 1926.502) requirements for more information on personal fall arrest systems and associated components.

2.0 SYSTEM REQUIREMENTS

2.1 **PERSONAL FALL ARREST SYSTEM COMPONENTS:** The Sayline horizontal lifeline must be used with DBI/SALA approved components and subsystems. Non-approved components may be incompatible, and could affect the safety and reliability of the complete system. Personal fall arrest components used with this system must meet all applicable OSHA and ANSI requirements. A full body harness must be used with this system. The connecting subsystem between the harness and horizontal lifeline must limit fall arrest forces to 900 lbs. or less.

2.2 **COMPATIBILITY OF CONNECTORS:** Connectors are considered to be compatible with connecting elements when they have been designed to work together in such a way that their sizes and shapes do not cause their gate mechanisms to inadvertently open regardless of how they become oriented. Contact DBI/SALA if you have any questions about compatibility.

Figure 3 - Unintentional Disengagement

If the connecting element to which a snap hook (shown) or carabiner attaches is undersized or irregular in shape, a situation could occur where the connecting element applies a force to the gate of the snap hook or carabiner. This force may cause the gate (of either a self-locking or a non-locking snap hook) to open, allowing the snap hook or carabiner to disengage from the connecting point.

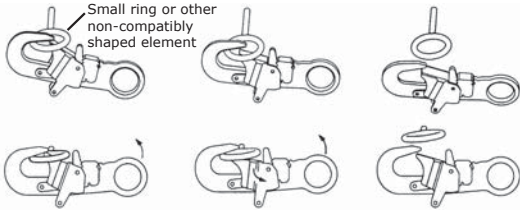

Force is applied to the Snap Hook. The Gate presses against the Connecting Ring. The Gate opens allowing the Snap Hook to slip off.

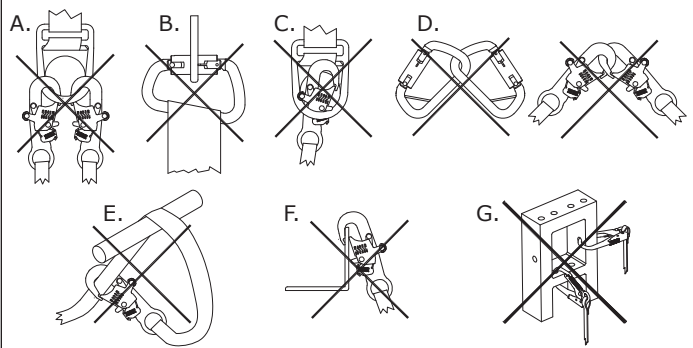
Figure 4 - Inappropriate Connections

Connectors (hooks, carabiners, and D-rings) must be capable of supporting at least 5,000 lbs. (22kN). Connectors must be compatible with the anchorage or other system components. Do not use equipment that is not compatible. Non-compatible connectors may unintentionally disengage. See Figure 3. Connectors must be compatible in size, shape, and strength. Self locking snap hooks and carabiners are required by ANSI Z359.1 and OSHA.

2.3 MAKING CONNECTIONS: Only use self-locking snap hooks and carabiners with this equipment. Only use connectors that are suitable to each application. Ensure all connections are compatible in size, shape and strength. Do not use equipment that is not compatible. Ensure all connectors are fully closed and locked.

DBI/SALA connectors (snap hooks and carabiners) are designed to be used only as specified in each product's user's instructions. See Figure 4 for inappropriate connections. DBI/SALA snap hooks and carabiners should not be connected:

- A. To a D-ring to which another connector is attached.
- B. In a manner that would result in a load on the gate.

NOTE: Large throat opening snap hooks should not be connected to standard size D-rings or similar objects which will result in a load on the gate if the hook or D-ring twists or rotates. Large throat snap hooks are designed for use on fixed structural elements such as rebar or cross members that are not shaped in a way that can capture the gate of the hook.

- C. In a false engagement, where features that protrude from the snap hook or carabiner catch on the anchor and without visual confirmation seems to be fully engaged to the anchor point.
- D. To each other.
- E. Directly to webbing or rope lanyard or tie-back (unless the manufacturer's instructions for both the lanyard and connector specifically allow such a connection).
- F. To any object which is shaped or dimensioned such that the snap hook or carabiner will not close and lock, or that roll-out could occur.
- G. In a manner that does not allow the connector to align properly while under load.

2.4 ANCHORAGE CONNECTORS: DBI/SALA does not supply anchorage fasteners. Connectors used to attach the horizontal lifeline to end anchors must be compatible with the connection point. The connection must be positive; and, with connecting elements, capable of sustaining a 5,000 lb. (22 kN) load without failure.

The intermediate brackets require a 1/2-13 UNC bolt meeting SAE Grade 5 strength minimum. A flat washer, lock washer and a nut are also required. A locking nut may be used in place of the lock washer and plain nut.

2.5 STRUCTURE LOAD: Structural anchorage points must be rigid, and capable of supporting at least 5,000 lbs. (22 kN) along the axis of the horizontal lifeline. Anchorages, including the intermediate brackets, must also support at least 3,600 lbs. (16 kN) applied in all potential directions of fall arrest that are perpendicular to the axis of the horizontal lifeline. See Figure 5.

WARNING: Anchorages must be rigid. Large deformations of the anchorage will affect system performance, and may increase the required fall clearance below the system, which could result in serious injury or death.

2.6 CONNECTING SUBSYSTEM: The connecting subsystem is the portion of the personal fall arrest system that is used to connect between the horizontal lifeline subsystem and harness fall arrest attachment element. The connecting subsystem must limit forces applied to the horizontal lifeline to 900 lbs. (4 kN) or less.

Figure 5 - Anchorage Strength

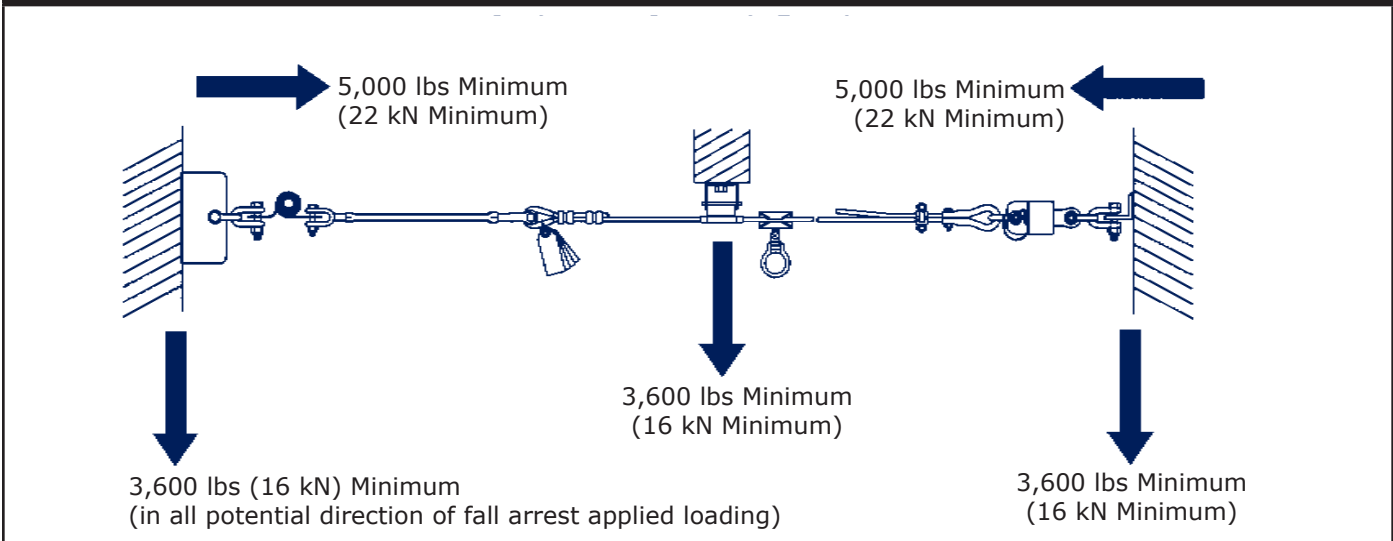

3.0 INSTALLATION

3.1 Inspection

Upon receipt of the Sayflite Horizontal Lifeline System, inspect all components and user equipment for defects and/or damage. If any Sayflite components or DBI/SALA equipment are found to be damaged, defective, or missing, contact DBI/SALA immediately for replacements. Do not use any defective or damaged parts in a Sayflite Horizontal Lifeline System installation.

WARNING: Use of defective or damaged parts will hinder the performance of the Sayflite system, potentially causing serious injury or death in the event of a fall.

3.2 Safety

A separate means of fall protection must be utilized during the installation of a Sayflite System. A separate means of fall protection must be used when inspecting or servicing a Sayflite System following a fall.

DBI/SALA recommends the use of certified eye protection, steel toe boots and gloves be worn during the installation of the horizontal lifeline system.

WARNING: Do not alter or intentionally misuse this equipment. Use caution when using this equipment around moving machinery, electrical and chemical hazards, and sharp edges.

3.3 SYSTEM INSTALLATION:

Figure 1 shows a typical horizontal lifeline system installation. When using an energy absorbing lanyard to connect to the system, the anchorages must be located at a height above the working level which will limit the free fall to six feet. The length of the lanyard must be considered when determining the height of the anchorages.

When using a self retracting lifeline (SRL) to connect to the system, the end anchorages must be located above the user. The SRL, when fully retracted, must be above the harness attachment level. The horizontal lifeline system should be positioned at a level that will minimize free fall while allowing ease of use.

The horizontal lifeline should be positioned near the work location to minimize swing fall hazards. The connecting subsystem length should be kept as short as possible to reduce the potential free fall and required clearance distance.

Both anchorages must be installed at approximately the same elevation, so that the horizontal lifeline system is not sloped more than a 1:12 pitch (1 inch [3 cm] rise over a 12 inch [30 cm] run). The cable must be in a straight line; no curves or turns are allowed in a Sayflink Multi-span Lifeline installation.

The installation process consists of the following steps:

1. Determine the location of end anchors and intermediate brackets.
2. Determine the orientation of the intermediate brackets
3. Attach one end to its anchor point.
4. Install cable guides and Sayflink sleeves onto the cable.
5. Assemble intermediate brackets into their anchor points.
6. Unthread turnbuckle(s)
7. Attach the other cable end to its anchor point and tension the cable

The steps are described in detail below:

Step 1. Determine the locations of the end anchorages and evaluate their strengths in accordance with section 2.4. Determine the number of intermediate brackets necessary for your application. There must be one intermediate bracket for every 30 feet (9 m) of cable for systems over 30 feet (9 m) in length. Additional intermediate brackets (Part No. 7608001) may be purchased from DBI/SALA. Use Figures 6 and 7 to determine the span length and evaluate the required clearance. Figures 6 and 7 apply to one or two users connected to the system.

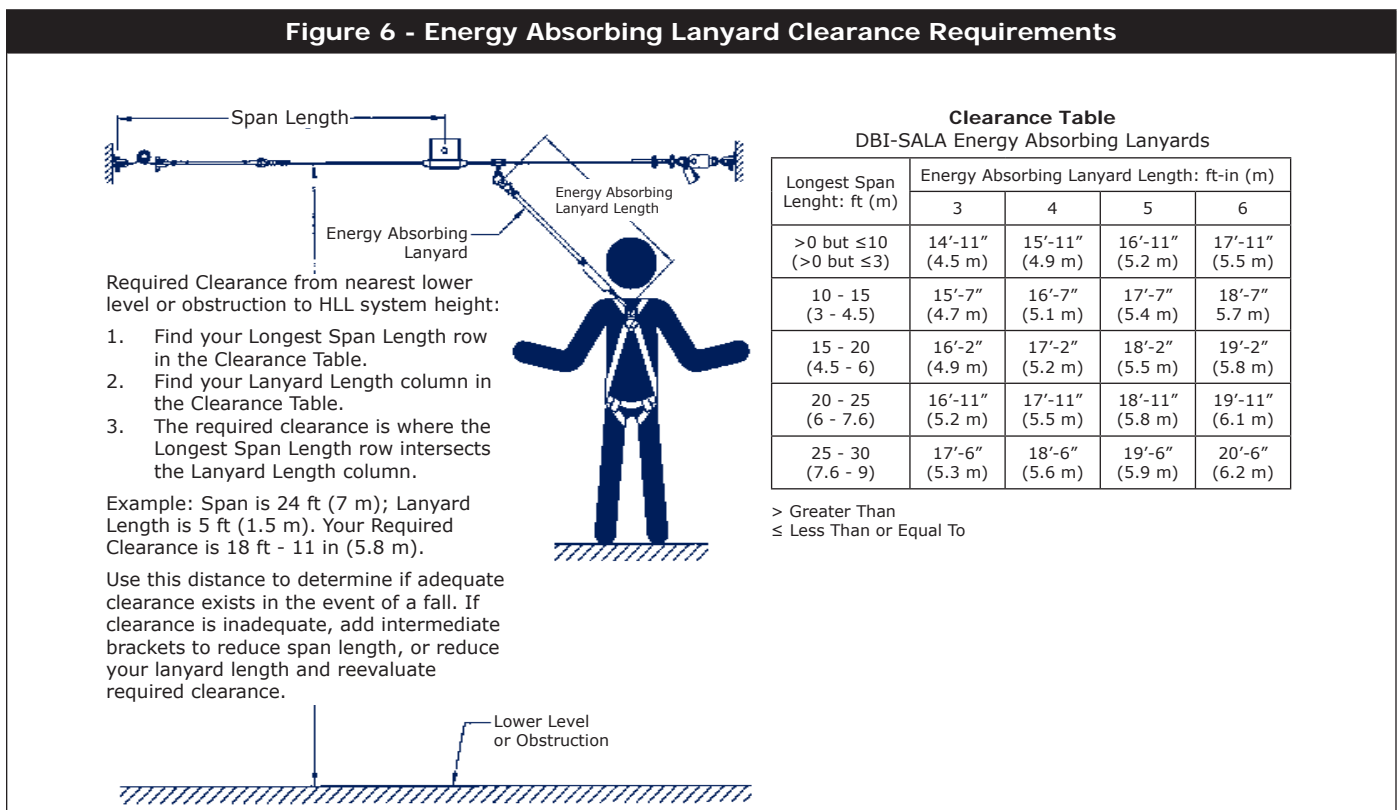
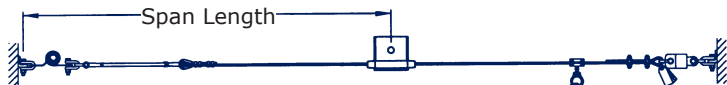

Figure 7 - Self Retracting Lifeline Clearance Requirements



Required Clearance from nearest lower level or obstruction to working level:

4. Find your longest span length row in the clearance table.
5. Read the required clearance distance from the distance column to determine if adequate clearance exists in the event of a fall. If there is inadequate clearance, add intermediate brackets to reduce the span length and reevaluate your required clearance.

Example: Span is 16 ft (5 m), Clearance required is 8 ft (2.5 m).

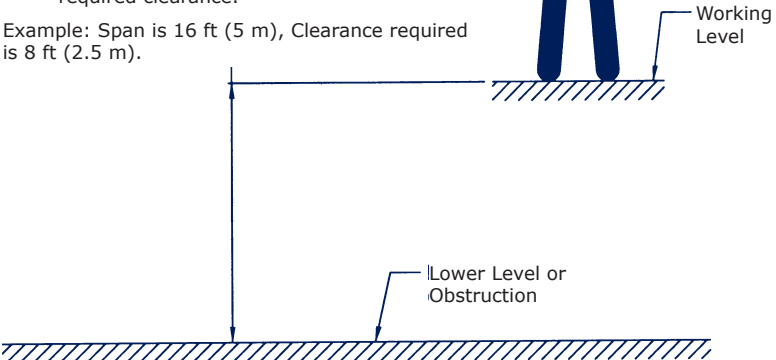

WARNING: This information only applies when the HLL and SRL are located overhead and above the level of the harness attachment point, and the user is standing.

Clearance Table
DBI-SALA Self Retracting Lifelines

Longest Span Length: ft (m)	Required Distance: ft-in (m)
>0 (0) but ≤10 (3)	6'-11" (2.1)
10 (3) - 20 (6)	8'-0" (2.4)
20 (6) - 30 (9)	9'-1" (2.8)

> Greater Than
≤ Less Than or Equal To

Step 2. Determine the correct orientation of the intermediate brackets. Depending on the positioning of the cable, the intermediate brackets may be installed in one of three orientations. See Figure 8 for the bracket orientations.

Note: A maximum free fall distance of 6 ft. must be maintained in all bracket positions; a system with brackets mounted below the user should only be used for fall restraint applications.

Figure 8 - Bracket Orientations

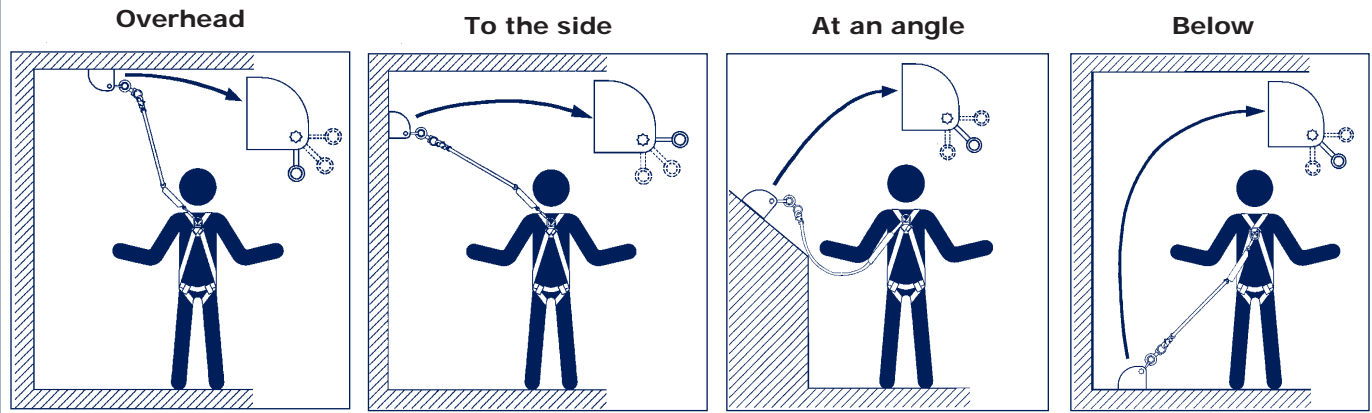

Step 3. To attach the cable to the first anchor point, link one pair of shackles together, then connect one side of the linked shackles to the anchor using the included nut and bolt. Connect the other side of the shackles to the Zorbit that's connected to the turnbuckle. See Figure 9. The horizontal lifeline system may be secured directly to the anchorage if the anchorage incorporates a connecting element that meets the requirements specified in section 2.4. The user must supply the anchorage hardware. Tighten bolts and nuts used to connect the system to the anchorage connectors. Slide the Saylink sleeve(s) onto the lifeline before terminating the other end of the cable to the anchor.

Step 4. If additional intermediate brackets are purchased, slide all of the cable guides from the brackets onto the cable before installing the cable.

Step 5. The intermediate brackets are composed of three parts: two side plates and a cable guide. Each of the plates is stamped with the letter "A" or "B". See Figure 10. To assemble a bracket, start by placing a cable guide into Part A at the appropriate angle as determined in Step 2. Then slide Part B onto the cable guide at the same angle and nestle Part B into Part A. Place the assembled bracket at its designated anchor point and anchor it by placing the user supplied bolt through a flat washer and then through the mated holes in the bracket and into the anchor point. The bolt may be installed through the anchor and into the bracket if preferred, but the washer must remain inside the bracket, between the bracket and the bolt head or nut. Torque the anchor hardware to 55 ft./lbs (75 nM).

Step 6. Before terminating the second end of the horizontal lifeline, unthread the turnbuckle on the first end so that only four threads are visible inside the turnbuckle body. This will allow for maximum tensioning of the system after anchoring the second end. Install all of the Saylink sleeves onto the cable before terminating the second end.

Step 7. To terminate the second end of the cable to its anchor, attach the shackles to the anchor and Zorbit as described in Step 3. Then attach the thimble and connecting hardware to the Zorbit. See Figure 11. Slide the lifeline through the thimble. Remove excess slack by pulling the wire rope through the thimble and cable clip. Maintain tension while torquing the cable clip nut and the thimble clip nut to the values specified in Figure 11. Tension the wire rope by turning the turnbuckle at the other end of the installation. The unrestrained turnbuckle jaw end must be prevented from turning to prevent twisting the wire rope. The wire rope must be tensioned until the sag on the system at mid-span, between intermediate brackets, is two inches or less, with no weight on the wire rope.

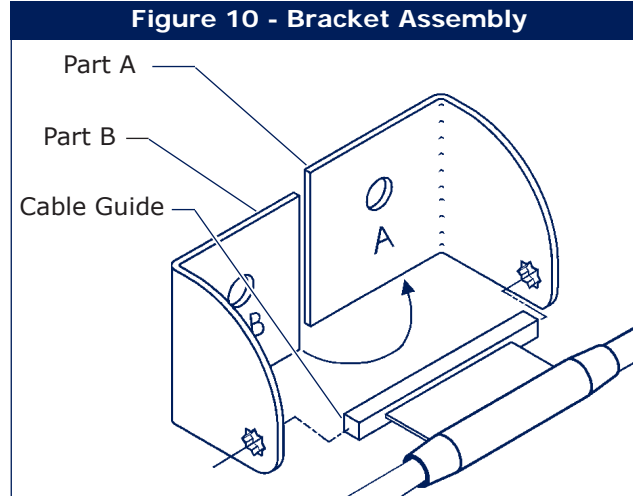
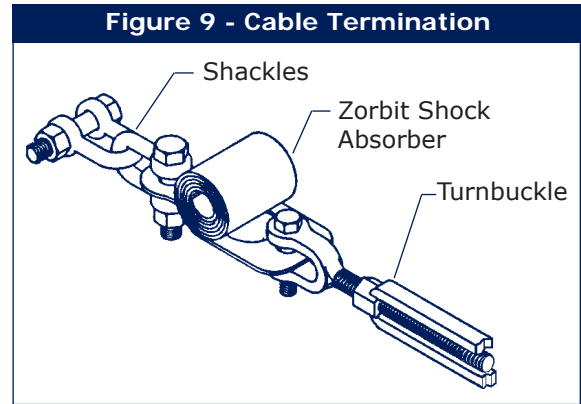
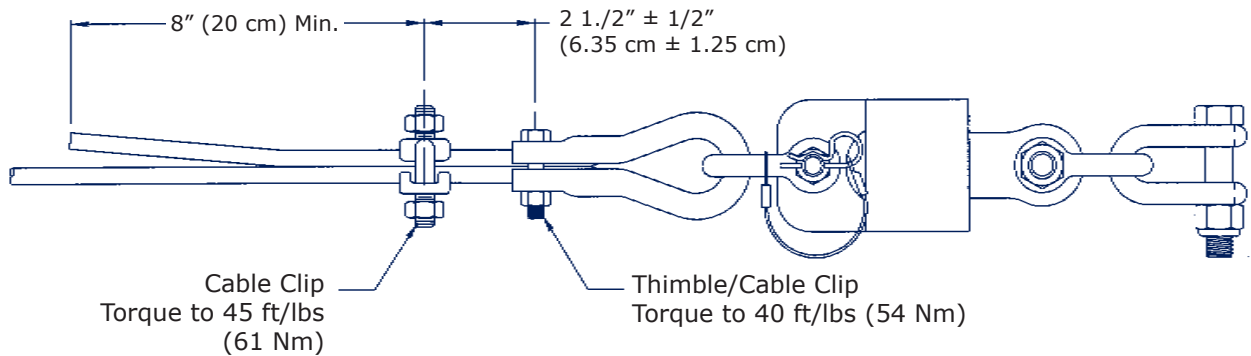
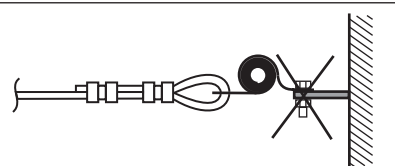

Figure 11 - Thimble/Cable Clip End Termination

Sayline Wire Rope HLL System End Termination



CAUTION: Do not rigidly mount Zorbit to structure or stanchion. May cause failure due to bending. Mount so Zorbit can pivot and move freely as shown in Figures 9 and 11.



4.0 OPERATION AND USE

WARNING: Consult your doctor if there is reason to doubt your fitness to absorb the impact from a fall arrest. Age and fitness can affect your ability to withstand fall arrest forces. Pregnant women and minors must not use the Sayflink Multi-span Wire Rope Horizontal Lifeline System.

4.1 BEFORE EACH USE inspect this equipment according to steps listed in section 6.4. Do not use this equipment if inspection reveals an unsafe or defective condition. Plan your use of the fall protection system prior to exposing workers to dangerous situations. Consider all factors affecting your safety before using this system.

- A. Read and understand all manufacturer's instructions for each component of the personal fall arrest system. All DBI/SALA harnesses and connecting subsystems are supplied with separate user instructions. Keep all instructions for future reference.
- B. Review sections 1.0 and 2.0 to ensure system limitations and other requirements have been adhered to. Review applicable information regarding system clearance criteria, and ensure changes have not been made to the system installation (i.e. length), or occurred at the job site, that could affect the required fall clearance. Do not use the system if changes are required.

4.2 USE OF THE SYSTEM:

- A. **PERSONAL FALL ARREST SYSTEM COMPONENTS:** Inspect and don the full body harness according to manufacturer's instructions. Attach the connecting subsystem (energy absorbing lanyard or self retracting lifeline) to the dorsal connection on the harness. If a self retracting lifeline (SRL) is used, DBI/SALA recommends using SRLs that are 20 feet (6 m) long or shorter. The weight of longer SRLs may cause the Sayflink sleeve to catch on intermediate brackets, causing the lifeline to extend which may result in an unexpected swing fall.

WARNING: If the Sayflink sleeve catches on an intermediate bracket, the SRL lifeline may extend while the worker moves along the HLL. This will increase fall distance and create a swing fall hazard which may result in serious injury or death.

- B. **CONNECTING TO THE HLL SYSTEM:** Approach the work area using the appropriate access equipment. Connect the personal fall arrest system to one of the D-rings on a Sayflink sleeve on the HLL. Connectors must meet all compatibility and strength requirements.
- C. **WALKING ALONG THE SYSTEM:** Once attached to the Sayflink System, the Sayflink Sleeve will follow the user along the lifeline and will automatically pass over each intermediate support bracket.

WARNING: Movement along the Sayflink System must be done manually by the user of the system. Never allow moving stock (such as railcars) to move the user along the Sayflink System. This could cause serious injury or death.

- D. **HAZARDOUS SITUATIONS:** Do not take unnecessary risks, such as jumping or reaching too far from the edge of the working surface. Do not allow the connecting subsystem to pass under arms or between feet. To avoid inadequate fall clearance, do not climb above the HLL. To avoid swing fall hazards, do not work too far from either side of the HLL.
- E. **TWO PERSONS CONNECTED TO THE HLL:** When a person falls while connected to the HLL, the system will deflect. If two persons are connected to the same HLL, and one person falls, the second person may be pulled off the working surface due to deflection. The potential for the second person falling increases as the HLL span length increases. The use of independent HLL systems for each person, or shorter span length, is recommended to minimize the potential of the second person falling.
- F. **FREE FALL:** The personal fall arrest system must be rigged to limit free falls to 6 ft. (1.8 m) or less when using an energy absorbing lanyard, or such that the SRL is overhead and without slack, according to OSHA requirements.
- G. **SHARP EDGES:** Avoid working where the connecting subsystem or other system components will be in contact with, or abrade against, unprotected sharp edges. If working around sharp edges is unavoidable, provide protection by securing a heavy pad or other means over the exposed edge.
- H. **IN THE EVENT OF A FALL:** The responsible party must have a rescue plan and the ability to implement a rescue. Tolerable suspension time in a full body harness is limited, so a prompt rescue is critical.

IMPORTANT: Use care when handling an expended Zorbit energy absorber. The tearing of the energy absorber material produces extremely sharp edges.

I. **RESCUE:** With the number of potential scenarios for a worker requiring rescue, an on site rescue team is beneficial. The rescue team is given the tools, both in equipment and techniques, so it can perform a successful rescue. Training should be provided on a periodic basis to ensure rescuers' proficiency.

4.3 SYSTEM REMOVAL: When no longer required, the HLL system should be removed from the job site. To slacken the HLL, loosen the turnbuckle until tension is removed from the wire rope. Disconnect the HLL system from the anchorages. Ensure there are no knots or kinks in the wire rope before storage.

5.0 TRAINING

5.1 It is the responsibility of all users of this equipment to understand these instructions, and to be trained in the correct installation, use, and maintenance of this equipment. These individuals must be aware of the consequences of improper installation or use of this equipment. This user manual is not a substitute for a comprehensive training program. Training must be provided on a periodic basis to ensure proficiency of the users.

6.0 INSPECTION

6.1 BEFORE EACH INSTALLATION: Inspect the Zorbit HLL energy absorbers, kit components, and other system components according to these or other manufacturer's instructions. System components must be formally inspected by a qualified person (other than the user). Formal inspections should concentrate on visible signs of deterioration or damage to the system components. Items found to be defective must be replaced. Do not use components if inspection reveals an unsafe or defective condition. Record results of each inspection in the inspection and maintenance log in section 11.0 of this manual.

6.2 INSTALLED SYSTEMS: An inspection of the HLL system by a qualified person must be completed after the system is installed. The system must be periodically inspected by a qualified person when left installed for an extended period. Periodic inspections should be performed at least monthly, or more frequently when site conditions and use warrant. Inspections of installed systems should include the inspection steps listed in section 6.4.

6.3 Annually: A Qualified Person shall inspect the entire system including the anchorage points. Inspect for deterioration or damage. Items found to be defective must be replaced. Do not use components if inspection reveals an unsafe or defective condition. Record the results of each inspection in the Inspection and Maintenance Log in section 11.0 of this manual.

6.4 BEFORE SYSTEM USE:

Step 1. Inspect the turnbuckle for damage. Ensure at least four threads are visible inside the turnbuckle body. Look for any cracks or deformities in the metal. Inspect metal components for rust or corrosion that may affect their strength or operation.

Step 2. Inspect the wire rope for rust, corrosion, broken wires, or other obvious faults. Inspect the HLL for proper tension. Inspect all hardware (fasteners, shackles, wire rope cable clips, etc.) securing the HLL assembly to ensure they are present and properly installed.

Step 3. Inspect the Sayflink Sleeve for excessive wear, damage, or corrosion.

Step 4. Inspect the Zorbit HLL energy absorber for extension or deformities. There should be no tearing of the metal between holes in the Zorbit coiled section. Increase inspection frequency if the Zorbit is exposed to prolonged vibration. Extended Zorbit HLL energy absorbers must be removed from service and destroyed, or marked for training only. Inspect securing hardware for strength and function.

Step 5. Inspect the intermediate brackets for wear or damage. Check brackets to make certain they are securely attached. Make certain all installed Sayflink sleeves pass freely through the intermediate brackets when moving along the system during normal use.

Step 6. Inspect system labels. The labels must be present and fully legible. See section 9.0. Replace labels if missing or illegible.

IMPORTANT: If this equipment is subjected to the forces of a fall arrest, it must be removed from service and destroyed, or returned to DBI/SALA for inspection or repair.

- 6.5 If inspection reveals an unsafe or defective condition, remove unit from service and destroy, or contact DBI/SALA for possible repair.
- 6.6 **USER EQUIPMENT:** Inspect harnesses and energy absorbing lanyards or SRL's used with the HLL system according to manufacturer's instructions.

7.0 MAINTENANCE, SERVICE, STORAGE

- 7.1 **MAINTENANCE:** The Sayline components require no scheduled maintenance, other than repair or replacement of items found defective during inspection. See section 6.0.
- 7.2 **CLEANING:** If components become heavily soiled with grease, paint, or other substances, clean with appropriate cleaning solutions.

Remove dirt from the cable using a fiber brush. Do not use a wire brush and do not apply any solvents or lubricants without prior approval from DBI/SALA. ^(A)

Clean all other Sayline components using a nonabrasive cloth and hot water/mild detergent mix. Dry with a clean cloth. Do not use solvents to clean any Sayline Component. Do not use caustic chemicals that could damage system components.

- 7.3 **USER EQUIPMENT:** Maintain, service, and store system components according to manufacturer's instructions for each component.

8.0 SPECIFICATIONS

8.1 MATERIALS:

- Zorbit Energy Absorber: Stainless steel
- Wire Rope: 3/8 inch diameter, 7x19 galvanized steel
- Bolts: Grade 5 or Grade 8 zinc plated steel
- Nuts: Zinc plated steel
- Intermediate Brackets: 11 ga. hot rolled steel, zinc plated
- Sayflink Sleeve Assembly: alloy steel
- Shackles: Galvanized steel, 5,000 lbs. (22 kN) minimum tensile strength
- Thimbles: Galvanized steel
- Turnbuckle: Galvanized steel, 5,000 lbs. (22 kN) minimum tensile strength
- Cable Clips: Galvanized steel

8.2 ENERGY ABSORBER PERFORMANCE:

- Peak Dynamic Pullout Load: 2,500 lbs. (11 kN)
- Average Dynamic Pullout Load: 2,000 lbs. (9 kN)
- Maximum Pullout: 48.5 inches (123 cm)
- Minimum Tensile Strength: 5,000 lbs. (22 kN)
- Patents Pending

9.0 LABELING

- 9.1 The following labels must be present and fully legible:

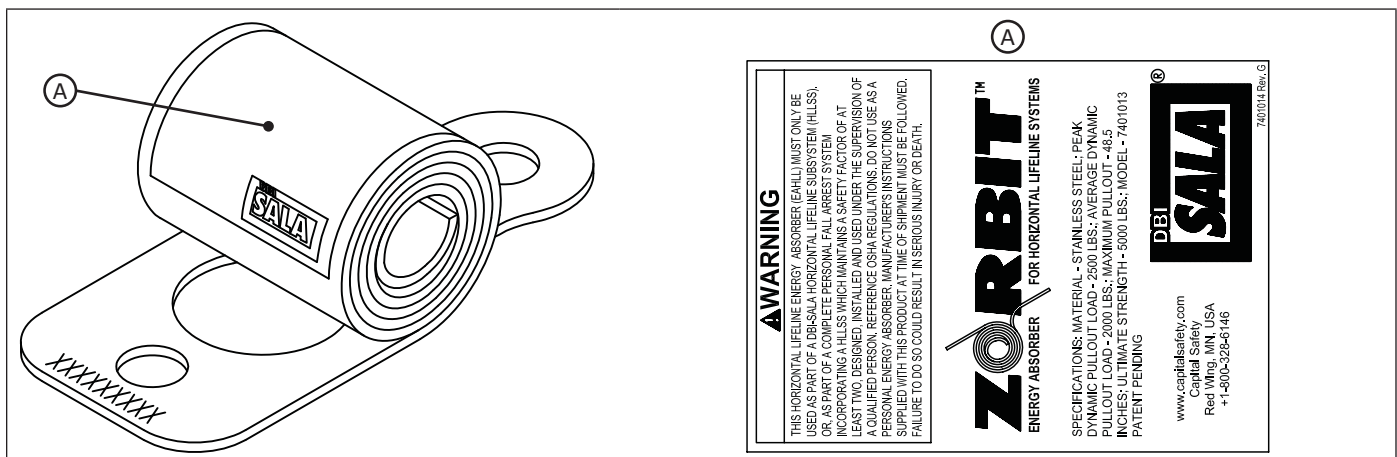

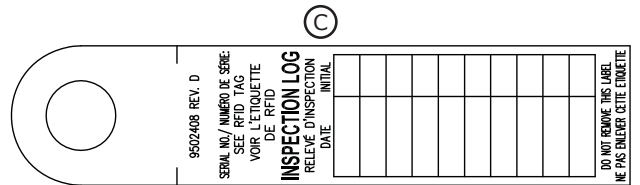
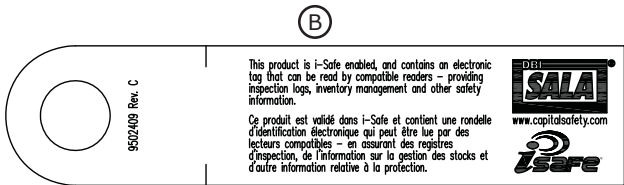
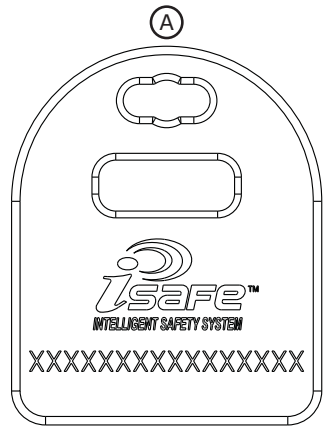
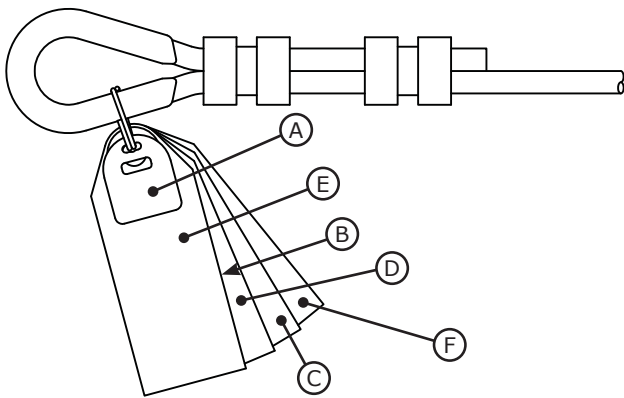

CLEARANCE REQUIREMENTS USING DBI/SALA ENERGY ABSORBING LANYARDS FROM THE LIFELINE ELEVATION TO THE NEAREST LOWER LEVEL OR OBSTRUCTION

SPAN LENGTH	LANYARD LENGTH			
	3 FT	4 FT	5 FT	6 FT
0' - 0" TO 9' - 11"	14' - 11"	15' - 11"	16' - 11"	17' - 11"
10' - 0" TO 14' - 11"	15' - 7"	16' - 7"	17' - 7"	18' - 7"
15' - 0" TO 19' - 11"	16' - 2"	17' - 2"	18' - 2"	19' - 2"
20' - 0" TO 24' - 11"	16' - 11"	17' - 11"	18' - 11"	19' - 11"
25' - 0" TO 30' - 0"	17' - 6"	18' - 6"	19' - 6"	20' - 6"

9500603 REV. B

INTERMEDIATE SUPPORTS ARE REQUIRED EVERY 30' - 0" MINIMUM. ADDITIONAL SUPPORTS MAY BE NECESSARY DUE TO CLEARANCE REQUIREMENTS. SEE USER INSTRUCTIONS.

CLEARANCE REQUIREMENTS USING DBI/SALA SELF RETRACTING LIFELINES FROM THE WORKING ELEVATION TO THE NEAREST LOWER LEVEL OR OBSTRUCTION

SPAN LENGTH	DISTANCE
0' - 0" TO 9' - 11"	6' - 11"
10' - 0" TO 19' - 11"	8' - 0"
20' - 0" TO 30' - 0"	9' - 1"

SRL MUST BE LOCATED ABOVE HARNESS ATTACHMENT POINT. CLEARANCE DATA REFLECTS A FALL FROM A STANDING POSITION.

INTERMEDIATE SUPPORTS ARE REQUIRED EVERY 30' - 0" MINIMUM. ADDITIONAL SUPPORTS MAY BE NECESSARY DUE TO CLEARANCE REQUIREMENTS. SEE USER INSTRUCTIONS.

PRODUCT COMPLIANCE

THIS PRODUCT COMPLIES WITH THE FOLLOWING STANDARDS ONLY IF MARKED WITH THE CORRESPONDING LETTER CODE UNDER "STDS" SECTION BELOW

A = ANSI Z359.1-99 B = OSHA C = ANSI A10.32-2004 D = ASTM F887-2005
E = ANSI Z359.3-07 F = ANSI Z359.4-07 G = ANSI Z359.1-07 H =

MFRD_(YR/MO): LOT: MODEL NO: MTRL: LENGTH_(FT): STDS:

MATERIAL DESIGNATION: (IDENTIFIED AFTER MODEL NO.)
P=POLYESTER - N=NYLON
C=CABLE - W=CHAIN
K=ARAMID - B=BLEND

LENGTH (FT.) IS DENOTED BY NUMBER AFTER MATERIAL DESIGNATION

CAPACITY:
ANSI Z359.1 - 130-310 LBS (59-140 kg)

DO NOT REMOVE THIS LABEL

9500305 Rev. H

WARNING

MANUFACTURER'S INSTRUCTIONS MUST BE READ AND UNDERSTOOD PRIOR TO USE. INSTRUCTIONS SUPPLIED WITH THIS PRODUCT AT TIME OF SHIPMENT MUST BE FOLLOWED FOR PROPER USE, MAINTENANCE, AND INSPECTION. ENSURE HORIZONTAL LIFELINE IS LOCATED AT AN ELEVATION WHICH WILL LIMIT FREE FALLS TO A MAXIMUM OF 6 FEET WHEN USING SHOCK ABSORBING LANYARDS, AND LOCATED OVERHEAD WHEN USING SELF RETRACTING LIFELINES. SHOCK ABSORBING LANYARDS AND SELF RETRACTING LIFELINES USED TO CONNECT TO THIS SYSTEM MUST LIMIT MAXIMUM ARRESTING FORCES TO 900 LBS. THIS EQUIPMENT MUST BE INSTALLED AND USED UNDER THE SUPERVISION OF A QUALIFIED PERSON. MAKE ONLY COMPATIBLE CONNECTIONS. EXERCISE CAUTION USING THIS EQUIPMENT NEAR HAZARDOUS THERMAL, ELECTRICAL, OR CHEMICAL SOURCES. ALTERATION OR MISUSE OF THIS PRODUCT, OR FAILURE TO FOLLOW INSTRUCTIONS MAY RESULT IN SERIOUS INJURY OR DEATH. REMOVE FROM SERVICE IF SUBJECT TO FALL ARREST FORCES. DO NOT REMOVE THIS LABEL.

9500400 REV. H

DBI/SALA

www.capitalsafety.com

INSPECTION AND MAINTENANCE LOG

SERIAL NUMBER:			
MODEL NUMBER:			
DATE PURCHASED:		DATE OF FIRST USE:	

INSPECTION DATE	INSPECTION ITEMS NOTED	CORRECTIVE ACTION	MAINTENANCE PERFORMED
Approved By:			
Approved By:			
Approved By:			
Approved By:			
Approved By:			
Approved By:			
Approved By:			
Approved By:			
Approved By:			
Approved By:			
Approved By:			
Approved By:			
Approved By:			
Approved By:			
Approved By:			
Approved By:			
Approved By:			

This instruction applies to the following product models:

7603000	7603070	7603074	7603080	7603160	7603240
7603020	7603071	7603075	7603100	7603180	7603260
7603040	7603072	7603076	7603120	7603200	7603299
7603060	7603073	7603079	7603140	7603220	7608001

Additional Model Numbers may appear on the next printing of this instruction.

LIMITED LIFETIME WARRANTY

Warranty to End User: D B Industries, Inc., dba CAPITAL SAFETY USA ("CAPITAL SAFETY") warrants to the original end user ("End User") that its products are free from defects in materials and workmanship under normal use and service. This warranty extends for the lifetime of the product from the date the product is purchased by the End User, in new and unused condition, from a CAPITAL SAFETY authorized distributor. CAPITAL SAFETY'S entire liability to End User and End User's exclusive remedy under this warranty is limited to the repair or replacement in kind of any defective product within its lifetime (as CAPITAL SAFETY in its sole discretion determines and deems appropriate). No oral or written information or advice given by CAPITAL SAFETY, its distributors, directors, officers, agents or employees shall create any different or additional warranties or in any way increase the scope of this warranty. CAPITAL SAFETY will not accept liability for defects that are the result of product abuse, misuse, alteration or modification, or for defects that are due to a failure to install, maintain, or use the product in accordance with the manufacturer's instructions.

CAPITAL SAFETY'S WARRANTY APPLIES ONLY TO THE END USER. THIS WARRANTY IS THE ONLY WARRANTY APPLICABLE TO OUR PRODUCTS AND IS IN LIEU OF ALL OTHER WARRANTIES AND LIABILITIES, EXPRESSED OR IMPLIED. CAPITAL SAFETY EXPRESSLY EXCLUDES AND DISCLAIMS ANY IMPLIED WARRANTIES OF MERCHANTABILITY OR FITNESS FOR A PARTICULAR PURPOSE, AND SHALL NOT BE LIABLE FOR INCIDENTAL, PUNITIVE OR CONSEQUENTIAL DAMAGES OF ANY NATURE, INCLUDING WITHOUT LIMITATION, LOST PROFITS, REVENUES, OR PRODUCTIVITY, OR FOR BODILY INJURY OR DEATH OR LOSS OR DAMAGE TO PROPERTY, UNDER ANY THEORY OF LIABILITY, INCLUDING WITHOUT LIMITATION, CONTRACT, WARRANTY, STRICT LIABILITY, TORT (INCLUDING NEGLIGENCE) OR OTHER LEGAL OR EQUITABLE THEORY.



The Ultimate in Fall Protection

CSG USA & Latin America

3833 SALA Way
Red Wing, MN 55066-5005
Toll Free: 800.328.6146
Phone: 651.388.8282
Fax: 651.388.5065
solutions@capitalsafety.com

CSG Canada

260 Export Boulevard
Mississauga, ON L5S 1Y9
Phone: 905.795.9333
Toll-Free: 800.387.7484
Fax: 888.387.7484
info.ca@capitalsafety.com

CSG Northern Europe

5a Merse Road
North Moons, Moat
Reditch, Worcestershire, UK
B98 9HL
Phone: + 44 (0)1527 548 000
Fax: + 44 (0)1527 591 000
csgne@capitalsafety.com

CSG EMEA (Europe, Middle East, Africa)

Le Broc Center
Z.I. 1ère Avenue
5600 M B.P. 15 06511
Carros
Le Broc Cedex
France
Phone: + 33 4 97 10 00 10
Fax: + 33 4 93 08 79 70
information@capitalsafety.com

CSG Australia & New Zealand

95 Derby Street
Silverwater
Sydney NSW 2128
AUSTRALIA
Phone: +(61) 2 8753 7600
Toll-Free : 1 800 245 002 (AUS)
Toll-Free : 0800 212 505 (NZ)
Fax: +(61) 2 87853 7603
sales@capitalsafety.com.au

CSG Asia

Singapore:
16S, Enterprise Road
Singapore 627666
Phone: +65 - 65587758
Fax: +65 - 65587058
inquiry@capitalsafety.com

Shanghai:

Rm 1406, China Venturetech Plaza
819 Nan Jing Xi Rd,
Shanghai 200041, P R China
Phone: +86 21 62539050
Fax: +86 21 62539060

www.capitalsafety.com

