

CUSTOMER SPECIFICATION DRAWING

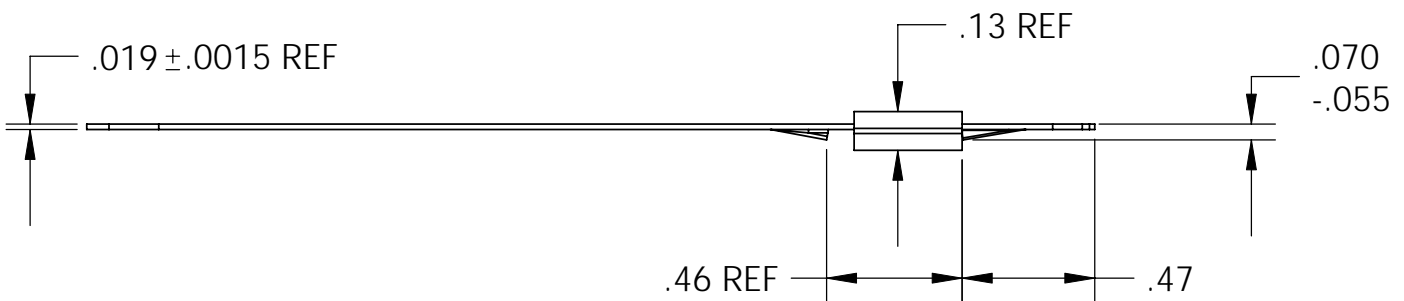
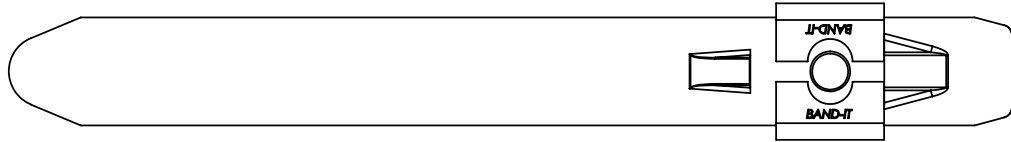

BAND-IT PART NUMBER	LENGTH	MATERIAL		QTY. PER BAG	EACH WEIGHT (LBS)
		BAND	BUCKLE		
GRA623	17.50"	304 SS	304 SS	50	2.04
GRA624	24.00"	304 SS	304 SS	50	2.74
GRA625	30.50"	304 SS	304 SS	50	3.43

NOTES:

1. BAND AND BUCKLE MATERIAL PER BAND-IT SPECIFICATION.
2. 500 LBS. MINIMUM LOOP TENSILE STRENGTH.

UNLESS OTHERWISE NOTED:
DIMENSIONS ARE IN INCHES
AFTER FINISH

TOLERANCES:

X ±0.100
 .XX ±0.020
 .XXX ±0.005
 .XXXX ±0.001
 ANGLES ±0.5°

BAND-IT®

A unit of Corporation
 P.O. Box 16307
 Denver, Colorado U.S.A.

PROPRIETARY AND CONFIDENTIAL

THIS DRAWING WITH ALL
 CONTENTS IS PROPERTY OF
 BAND-IT. REPRODUCTION,
 DISCLOSURE OR MFG.
 OF MATTER SHOWN IS PROHIBITED
 WITHOUT WRITTEN PERMISSION.

DO NOT SCALE DRAWING

TITLE:

**TIE-LOK TIE,
 3/8" WIDE, SID,
 GRAINGER**

DWG. NO.

GRA62

REV -

SHEET 1 OF 1