

LOAD CLAMP

Push tension handle all the way forward. Insert BAND-IT Center Punch clamp tail and push all the way into tool.

Tool Tip: To apply 3/8" wide clamps, use S03289 adapter kit. See attached instructions for 3/8" adapter.

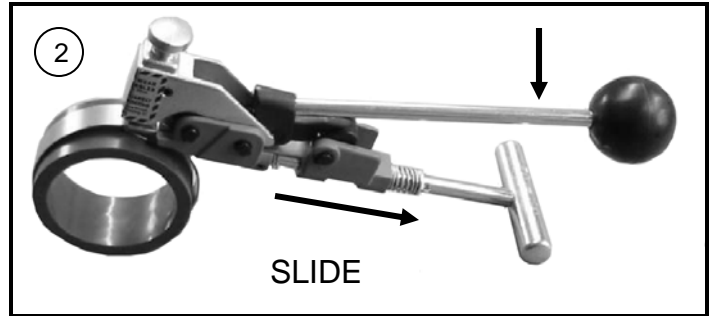

TIGHTEN CLAMP

Tighten the clamp with short downward strokes. Tension handle should be in down position at completion of tightening clamp.

Note: Do not lift tension handle too high as it may open up buckle pusher, resulting in improper clamp application.

If clamp tension needs to be released before locking, move handle forward and move slide back against spring. This raises pulling dog and release clamp tension.

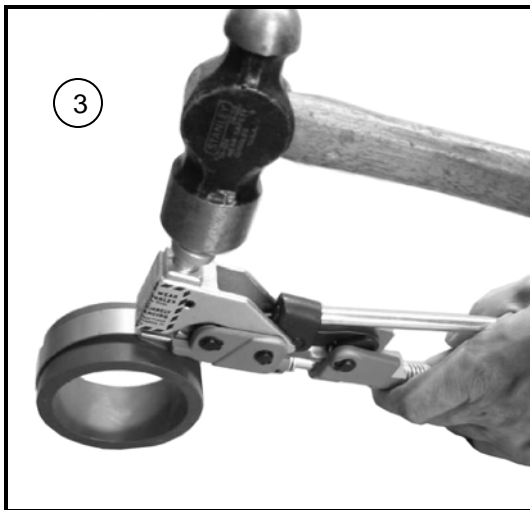

LOCK CLAMP

Holding tension handle down, lock clamp by hitting punch at least twice with 2 lb. Mallet.

Note: Only use genuine BAND-IT Center Punch clamps. Disregarding this may result in substandard clamps or tool failure. BAND-IT CP clamps are made out of Type 201 Stainless Steel or Galvanized Carbon Steel material with a stainless steel buckle for added strength.

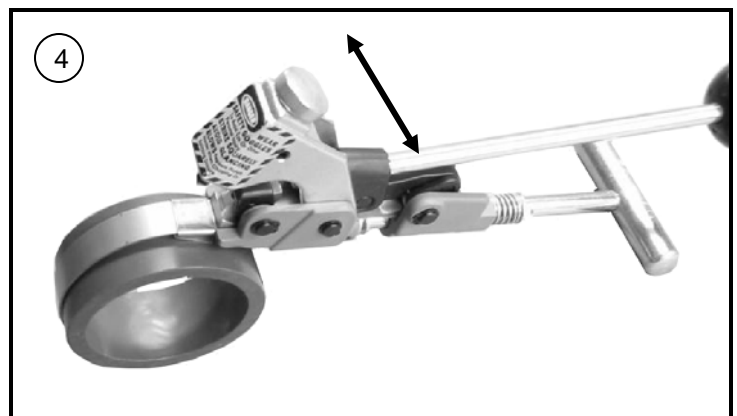

REMOVE CLAMP TAIL

Hold hose and pivot the tool back and forth to break off clamp tail. Remove tail from tool by operating tension handle. When tail has moved through holding dog, raise tension handle and pull tail free.

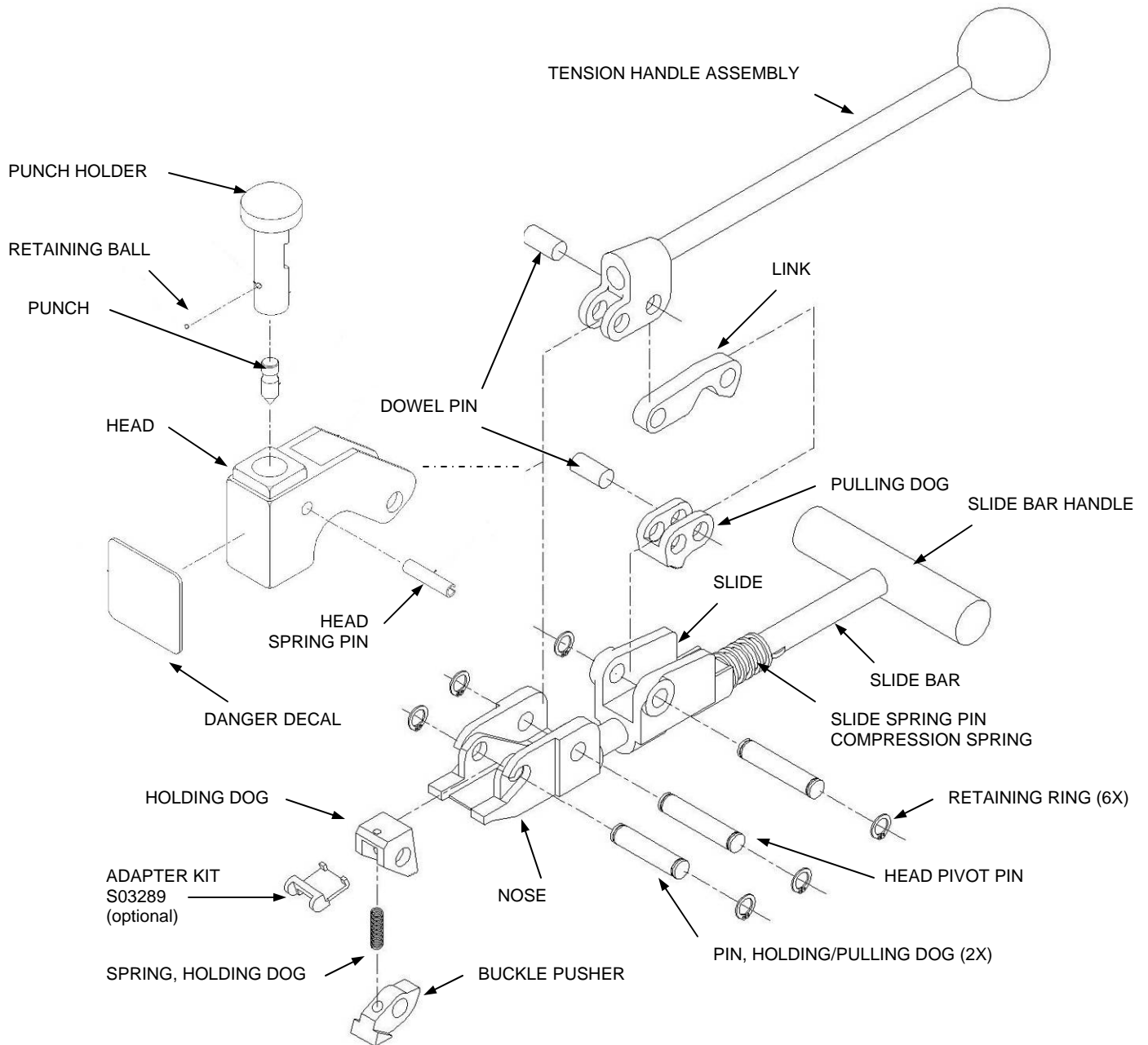

INSTRUCTIONS: **DISSASSEMBLY AND ASSEMBLY OF PUNCH**

To replace the punch, remove the head spring pin. Rotate the punch holder until the retaining ball is visible on inside of head. Remove the retaining ball and pull the punch out. Replace punch and reassemble in reversed manner.



REPAIR PARTS LIST FOR GRT300

PART NUMBER	DESCRIPTION
S05777	BUCKLE PUSHER
T26487	SPRING, HOLDING DOG
S05887	HOLDING DOG
T28088	HEAD ASSEMBLY INCLUDES: HEAD SPRING PIN, DANGER DECAL, HEAD, PUNCH, RETAINING BALL, AND PUNCH HOLDER
J64287	HEAD SPRING PIN
T25987	DECAL, DANGER
T27488	HEAD
S19087	PUNCH
T25587	RETAINING BALL, 5/32" DIA.
T25287	PUNCH HOLDER
T32190	PUNCH KIT INCLUDES: PUNCH, PUNCH HOLDER AND RETAINING BALL
T27988	TENSION HANDLE ASSEMBLY
T28888	NOSE AND SLIDE ASSEMBLY INCLUDES: NOSE, SLIDE, COMPRESSION SPRING, SLIDE SPRING PIN, AND SLIDE BAR HANDLE
T28740	NOSE
T27040	SLIDE
A04987	COMPRESSION SPRING, 5/8" DIA.
C09787	SPRING PIN, 1/8" DIA.
T28687	SLIDE BAR AND HANDLE ASSEMBLY:
T27288	LINK
T32290	GRIPPER KIT INCLUDES: PULLING DOG, 2 COMPRESSION SPRINGS, 3 RETAINING RINGS AND HOLDING DOG
T27187	PULLING DOG
T26787	DOWEL PIN, 5/16" DIA.
S06887	PIN, PULLING/HOLDING DOG
S06987	PIN, HEAD PIVOT
S08387	RETAINING RING, 5/16" DIA.
S03289	Adapter insert to install 3/8" wide Center Punch Clamps (Optional)

1. To convert GRT300 center punch tool, rotate head back to expose buckle pusher and nose of tool.
2. Press down on the lobe at the rear of the buckle pusher to raise the front portion for insertion of adapter between the buckle pusher and the nose.
3. Seat the adapter against the buckle pusher with the post of the adapter hooked at the rear of the triangle shapes of the buckle pusher. Release the pressure on the buckle pusher lobe to secure the adapter into place. Rotate the head forward. The tool is now ready to use.
4. Repeat instructions 1 and 2 to remove adapter.

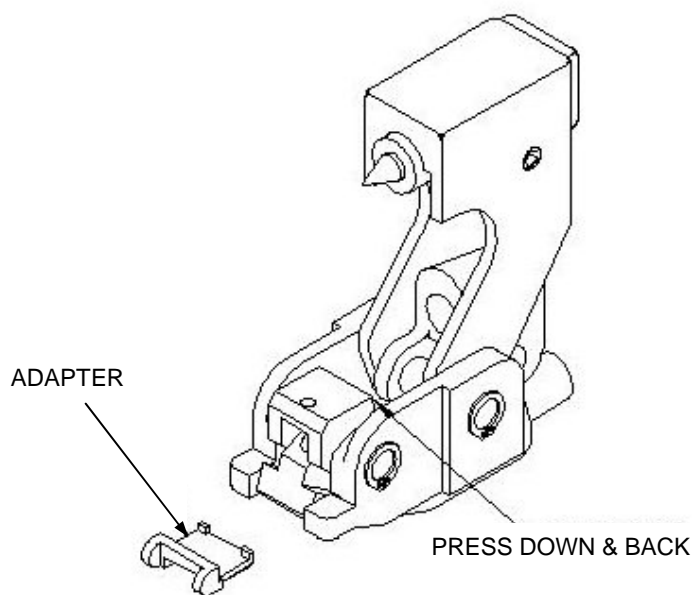

Warranty:

For Warranty information, visit the following URL

www.BAND-IT-IDEX.com/Warranty.html