

1. Tool is designed specifically for 3/8" and 5/8" center punch clamps only. Insert clamp in tool and then insert wrench assembly. If you prefer, install wrench assembly before clamp is inserted. Slot must be aligned with clamp tail.

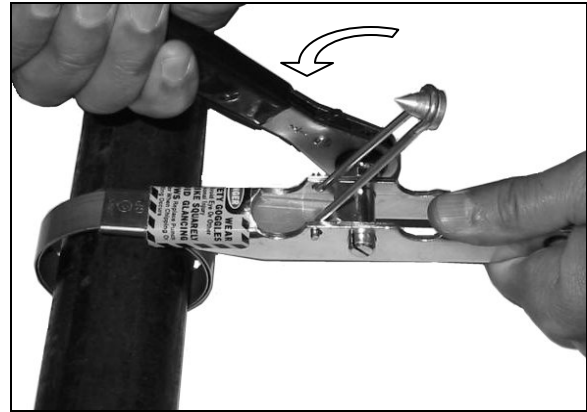

2. Start "pumping" ratchet wrench forward until proper tension has been applied.

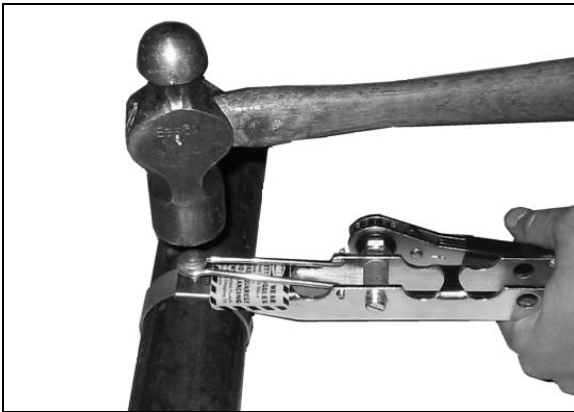

3. Place punch on clamp and while holding tension with ratchet wrench, lock clamp by striking punch once or more with hammer, depending on object being clamped.

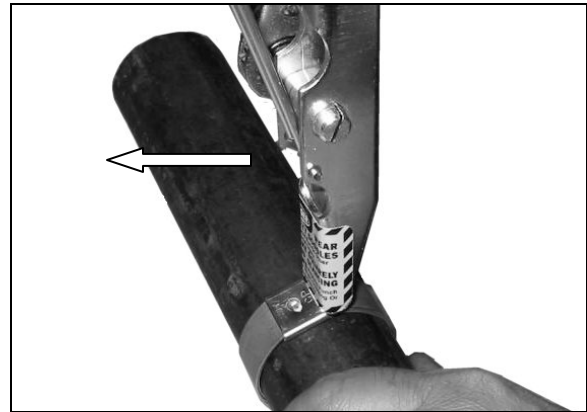

4. While holding tension with wrench, pivot tool up against buckle, then backward several times to break off clamp tail.

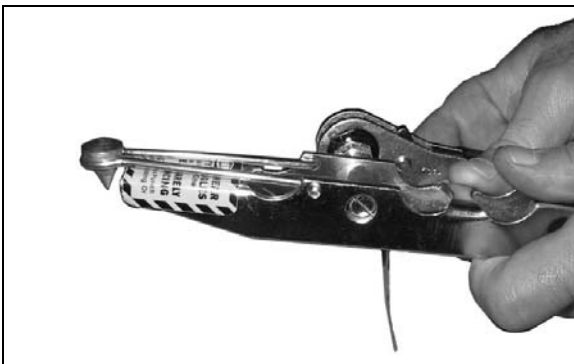

5. To loosen clamp tail, wind ratchet wrench until tail is free. Remove ratchet wrench assembly and clamp tail. *Caution: Clamp tail may spring back once released from tool nose.*

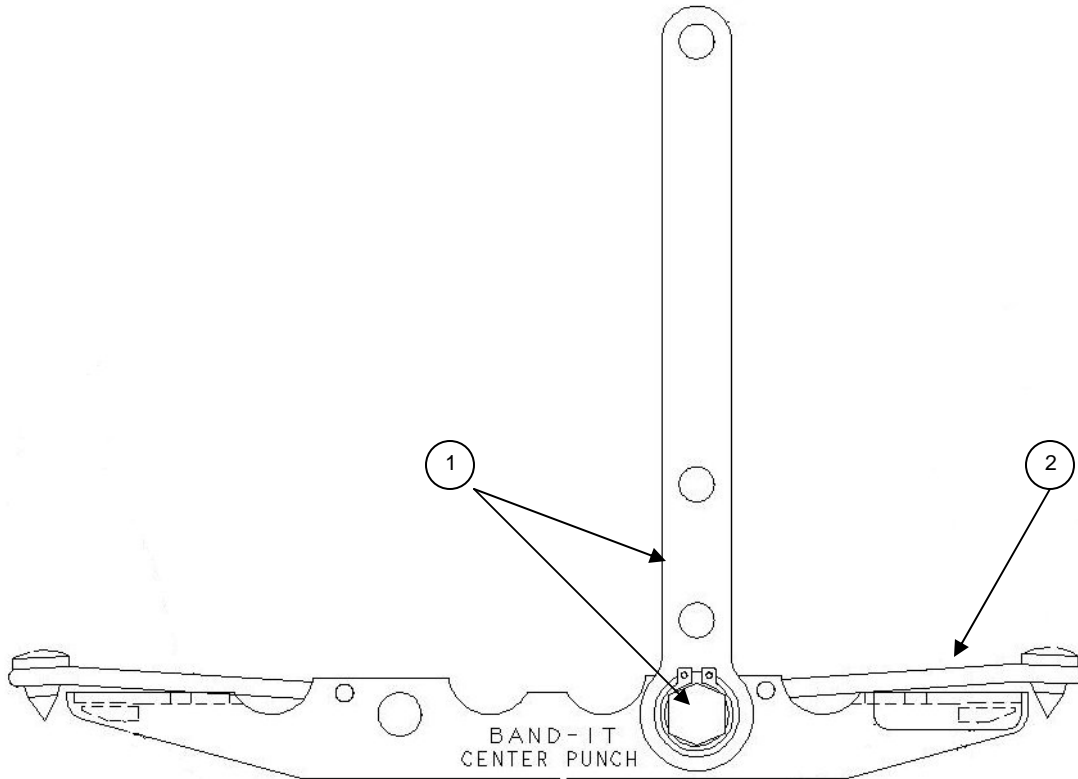

REPAIR PARTS LIST – GRS038 CENTER PUNCH TOOL		
ITEM NUMBER	PART NUMBER	DESCRIPTION
1	J02786*	WINDING MANDREL ASSEMBLY
2	S20288	PUNCH HOLDER ASSEMBLY

\*REPAIR PARTS MAY APPEAR DIFFERENT THAN ILLUSTRATED.

Refer to website for warranty information: <http://www.band-it-idex.com/warranty.html>