

Operating Instructions



GRG402 Giant II Hand Tool



1. Band may be used from bulk roll as this *completely eliminates waste of band*. Slide buckle on band as shown, bringing end of band around object to be clamped and again through buckle.



2. Continue band around object once more and again through buckle. *Double banding develops a great deal more radial compression than single banding*. Bend end of band under buckle.



3. Place band in open of tool nose and gripper block. Move into slot as far as possible, to avoid buckle sliding into tool nose. Apply tension by turning handle of tool.



4. Place finger on BAND-IT Band at buckle bridge while tensioning with tool handle. When you feel BAND-IT Band stop moving through buckle as you are turning handle, *maximum pressure is being exerted by the BAND-IT Band* around object being clamped. *Stop turning handle*.



5. *Roll tool over buckle, backing off with tension handle 1- 1½ turns throughout entire rolling operation*. Failure to back off tension with tension handle throughout entire course of roll-over may result in breaking of band. There is no loss of tension as band released is used up in the bend.



6. Pull cutting handle to cut the band. When applying Giant Band clamps, prior to cutting off clamp, release band gripper and push tool nose away from buckle approx. ¼".



7. Remove tool, holding stub of band down with thumb.



8. Hammer down buckle ears to complete BAND-IT clamp.

Gripper Cleaning Instructions:



1. Remove gripper. Align gripper pin hole with notch in tool frame. Using a punch and hammer, punch pin out of slide block.



2. Using a wire brush, clean all foreign matter from teeth.



3. Replace pin: Align gripper hole with slide block hole, insert pin in hole and hammer pin in place.

NOTE: Periodically apply food-grade white lubricant or equivalent to tension screw thread (on page 3) to prevent excessive wear.

If tool fails to securely grip tail of clamp, follow gripper cleaning instructions above.

Refer to website for warranty information: <http://www.band-it-idex.com/warranty.html>

Tool Assembly Parts List



GRG402 Giant II Hand Tool

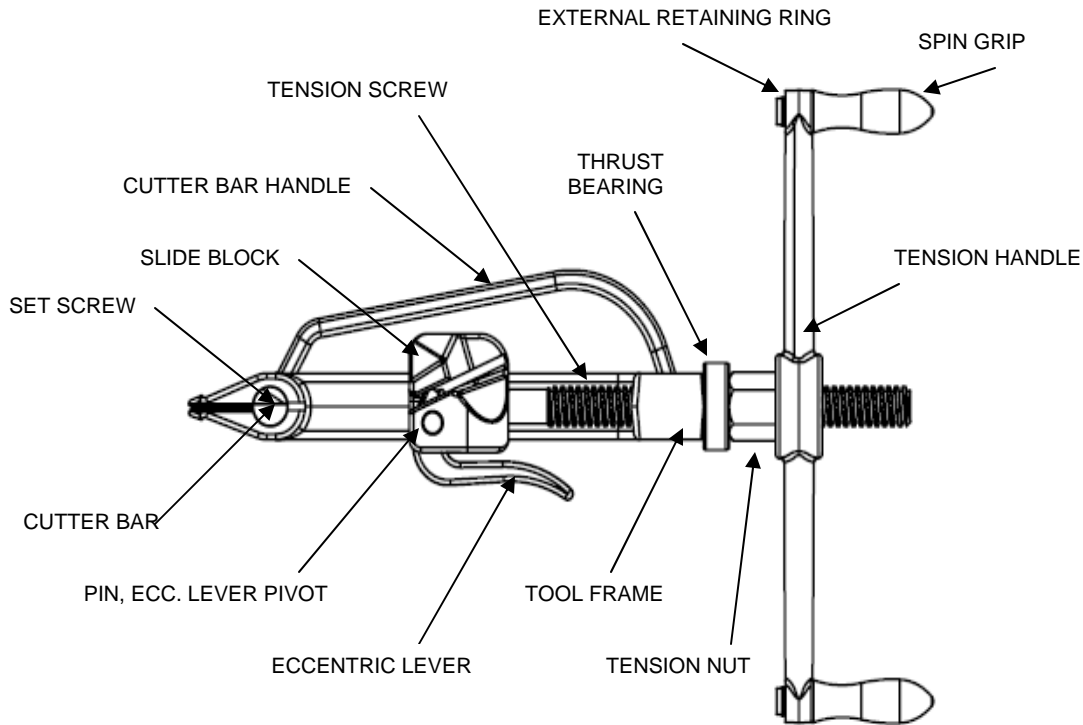

1. To assist in removing threaded parts, apply heat to soften locking compound.

2. When connecting the tension screw to the slide block, clean threads (male and female) of foreign matter, then apply two drops of high strength locking compound (Loctite 271 or equiv.) onto male threads and connect parts together. Apply 3 oz. of white lubricant or equiv. to tension screw thread.

3. When connecting the set screw to the cutter bar, clean threads (male and female) of foreign matter, then apply one drop of medium strength locking compound (Loctite 242 or equiv.) onto male thread and connect parts together.

REPAIR PARTS LIST FOR GRG402

PART #	DESCRIPTION
G41387	TOOL FRAME
G40888	THRUST BEARING
G42487	SLIDE BLOCK ASSEMBLY INCLUDES: SLIDE BLOCK, TENSION SCREW, TENSION NUT, ECCENTRIC LEVER, AND LEVER PIVOT PIN
G42087	TENSION HANDLE ASSEMBLY INCLUDES: TENSION HANDLE, SPIN GRIP AND EXTERNAL RETAINING RING
G42287	CUTTER BAR ASSEMBLY INCLUDES: CUTTER BAR HANDLE, CUTTER BAR, AND SET SCREW (ON FAR SIDE)