

CUSTOMER SPECIFICATION DRAWING

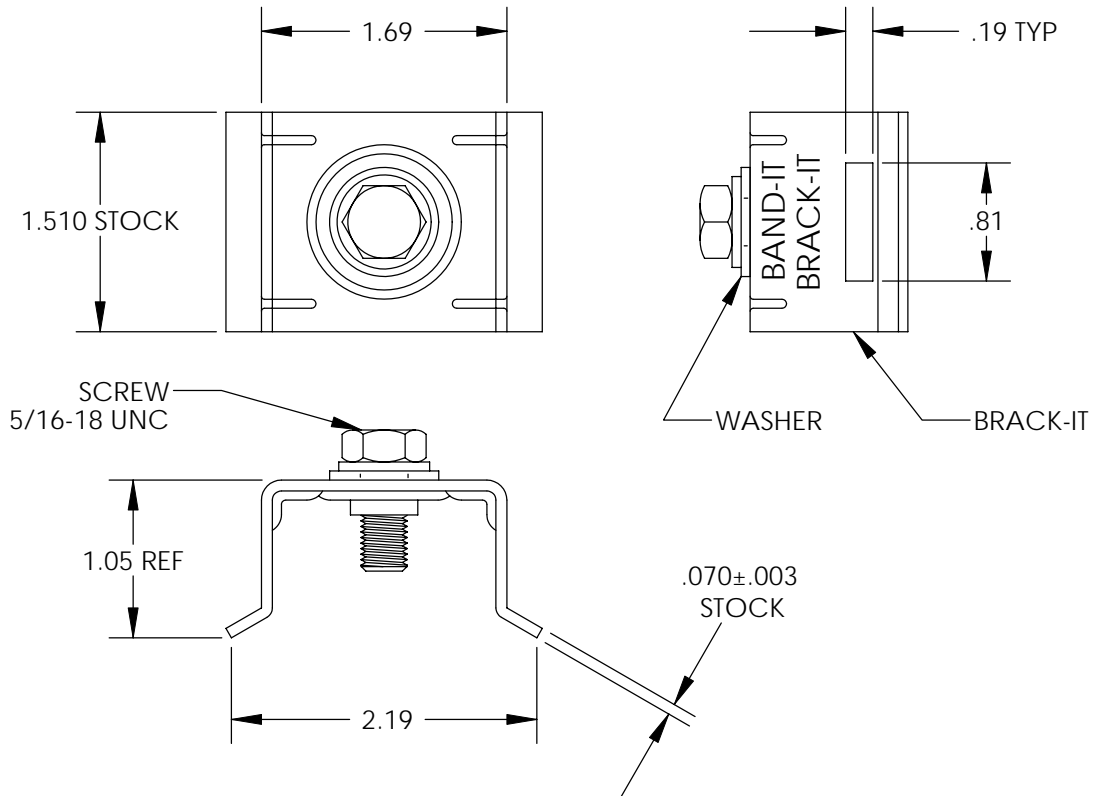

NOTES:

- 25 ASSEMBLIES PER BOX.
- MATERIAL: BRACK-IT: 200/300 STAINLESS STEEL
 SCREW: 304 STAINLESS STEEL
 WASHERS: 18-8 STAINLESS STEEL AND POLYPROPYLENE

ABOVE SPECIFICATION CERTIFIED BY: _____ DATE: _____

TITLE: _____

UNLESS OTHERWISE NOTED:
 DIMENSIONS ARE IN INCHES
 AFTER FINISH

TOLERANCES:
 .X ±0.100
 .XX ±0.020
 .XXX ±0.005
 .XXXX ±0.001
 ANGLES ±0.5°

BAND-IT®

A unit of **IDEX** Corporation
 P.O. Box 16307
 Denver, Colorado U.S.A.

PROPRIETARY AND CONFIDENTIAL

THIS DRAWING WITH ALL
 CONTENTS IS PROPERTY OF
 BAND-IT-IDEX, INC.
 REPRODUCTION, DISCLOSURE OR
 MFG. OF MATTER SHOWN IS
 PROHIBITED WITHOUT WRITTEN
 PERMISSION.
 DO NOT SCALE DRAWING

TITLE:

**BRACK-IT ASSEMBLY,
 FLARED LEG, GRAINGER**

DWG. NO.

GRD021

REV -

SHEET 2 OF 2