

# CUSTOMER SPECIFICATION DRAWING

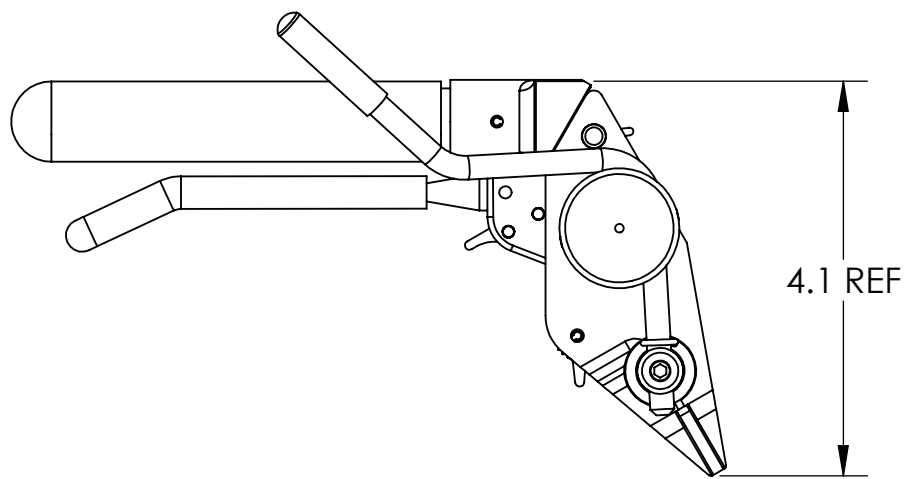
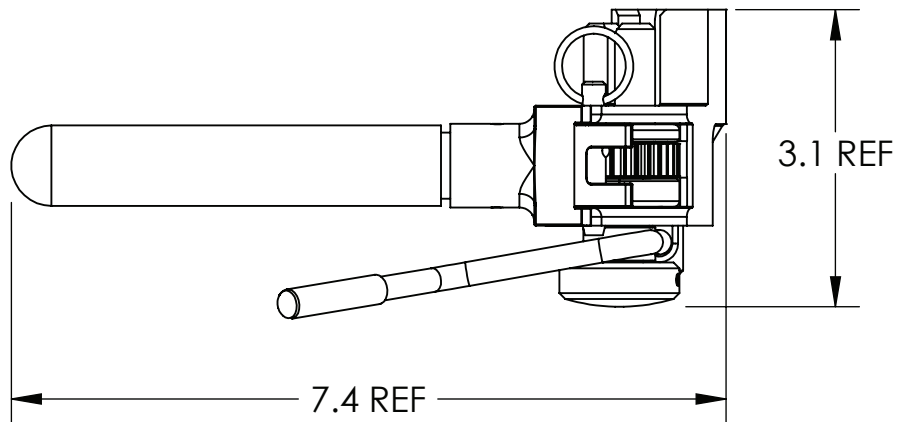

## NOTES:

1. BOX CONTENTS: TOOL AND INSTRUCTION SHEET.
2. WEIGHT: 2.60 LBS.
3. MATERIAL AND FINISH COMPLIES WITH EUROPEAN UNION RESTRICTION OF HAZARDOUS SUBSTANCES DIRECTIVE 2002/95/ED (RoHS).

UNLESS OTHERWISE NOTED:  
DIMENSIONS ARE IN INCHES  
AFTER FINISH

### TOLERANCES:

.X ..... ±0.100  
.XX ..... ±0.020  
.XXX ..... ±0.005  
.XXXX ..... ±0.001  
ANGLES ..... ±0.5°

**BAND-IT<sup>®</sup>**

A unit of **IDEX** Corporation  
P.O. Box 16307  
Denver, Colorado U.S.A.

### PROPRIETARY AND CONFIDENTIAL

THIS DRAWING WITH ALL  
CONTENTS IS PROPERTY OF  
BAND-IT-IDEX, INC.  
REPRODUCTION, DISCLOSURE OR  
MFG. OF MATTER SHOWN IS  
PROHIBITED WITHOUT WRITTEN  
PERMISSION.  
DO NOT SCALE DRAWING

TITLE:

**BANTAM COMBINATION  
TOOL**

DWG. NO.

**GRC075**

REV A

SHEET 2 OF 2