

CUSTOMER SPECIFICATION DRAWING

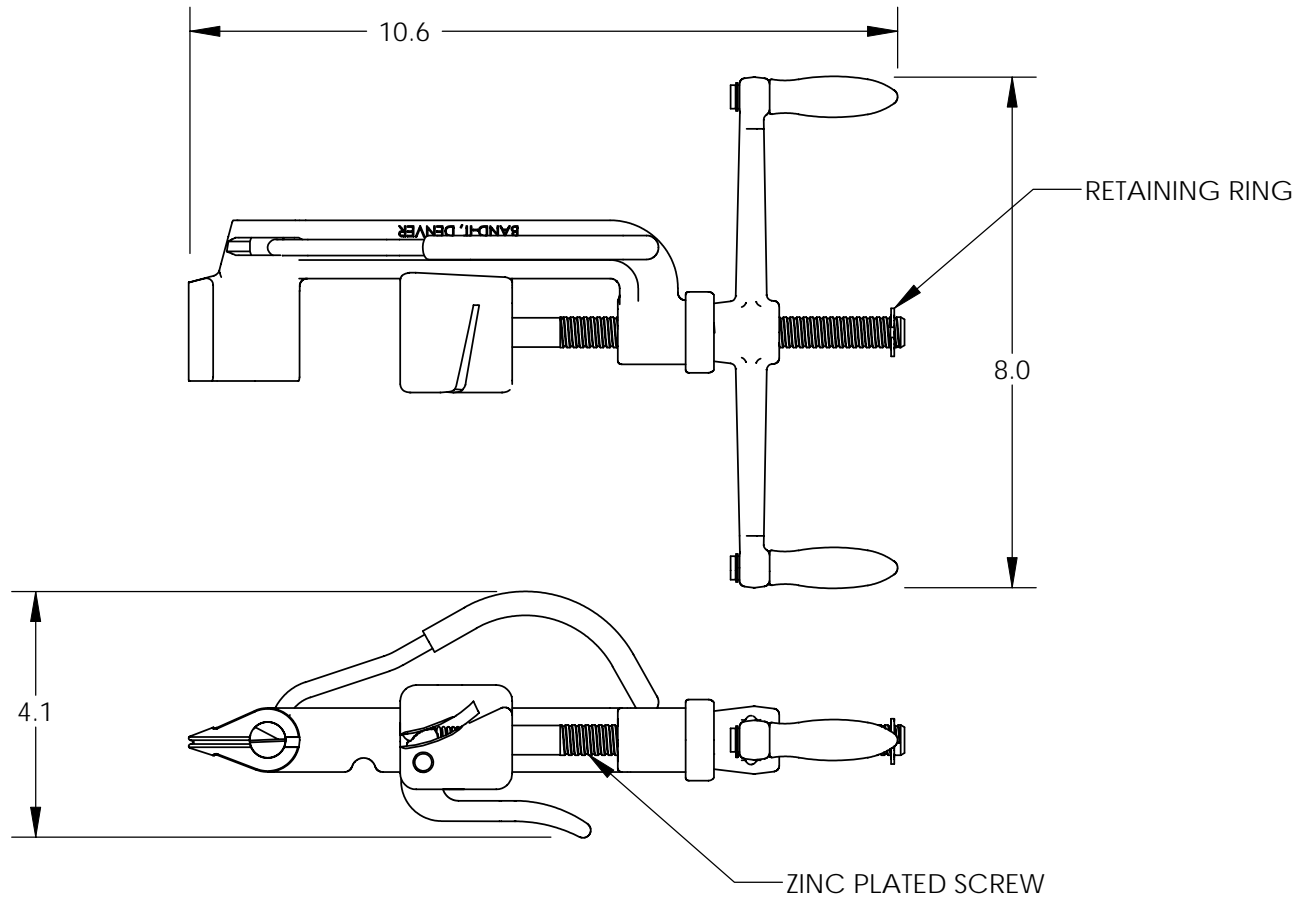

NOTES:

1. SHIPPING BOX DIMENSIONS: 10.0 X 4.0 X 2.75"
2. BOX CONTENTS: TOOL AND INSTRUCTION SHEET
3. WEIGHT: 4.5 LBS.
4. MATERIAL AND FINISH COMPLIES WITH EUROPEAN UNION RESTRICTION OF HAZARDOUS SUBSTANCES DIRECTIVE 2002/95/EC (RoHS)

ABOVE SPECIFICATION CERTIFIED BY: _____ DATE: _____

TITLE: _____

UNLESS OTHERWISE NOTED:
DIMENSIONS ARE IN INCHES
AFTER FINISH

TOLERANCES:

X ±0.100
.XX ±0.020
.XXX ±0.005
.XXXX ±0.001
ANGLES ±0.5°

BAND-IT®

A unit of **DEX** Corporation
P.O. Box 16307
Denver, Colorado U.S.A.

PROPRIETARY AND CONFIDENTIAL

THIS DRAWING WITH ALL
CONTENTS IS PROPERTY OF
BAND-IT. REPRODUCTION,
DISCLOSURE OR MFG.
OF MATTER SHOWN IS PROHIBITED
WITHOUT WRITTEN PERMISSION.

DO NOT SCALE DRAWING

TITLE:

BAND-IT TOOL, BOXED

DWG. NO.

GRC001

REV -

SHEET 2 OF 2