

STEEL CHUTE HOPPERS - C-HOP-200

APPROX WEIGHT: 805.31 lbs.
DOES NOT INCLUDE WEIGHT OF POWER OR PACKAGING!!!

*** ANY ADDITIONS, DELETIONS, OR OMISSIONS MUST BE CORRECTED ON THIS DRAWING AS THIS DRAWING WILL BE CONSIDERED ALL INCLUSIVE ***

ALL GRAPHICS PROVIDED ARE FOR REFERENCE ONLY. IF CERTAIN DIMENSIONS ARE CRITICAL PLEASE VERIFY THOSE DIMENSIONS WITH YOUR SALESPERSON

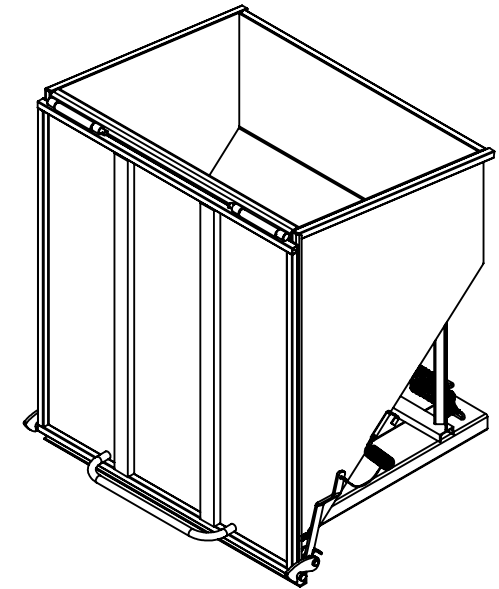
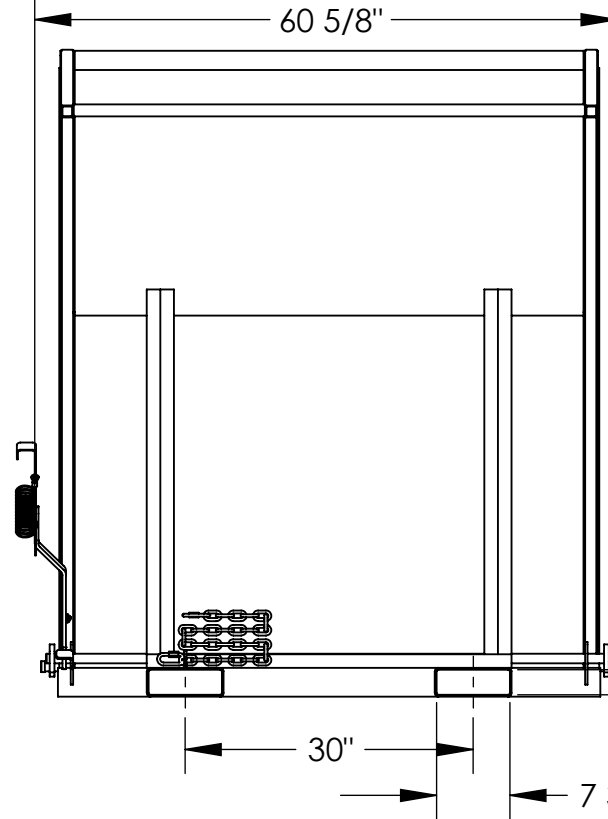
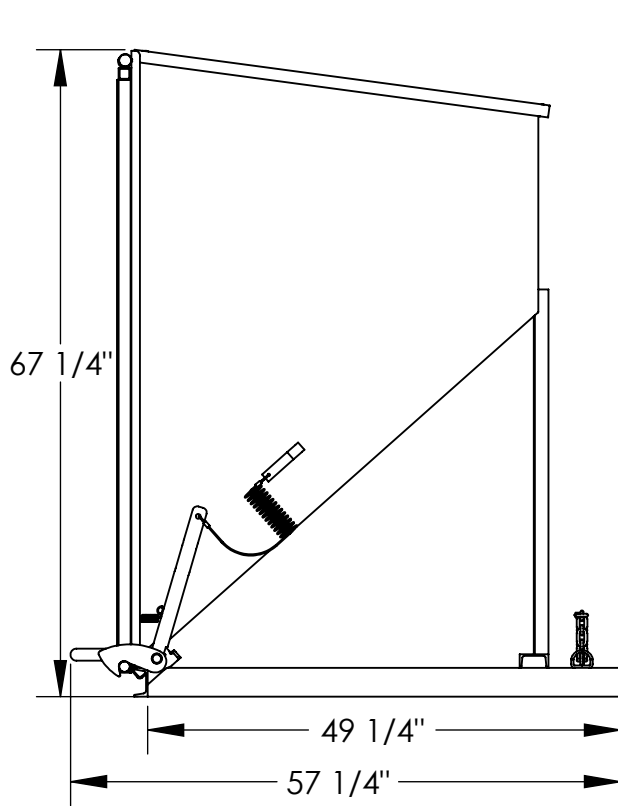

2 3/4"
NEVER EXCEED LOAD CENTER RATING PER FORK TRUCK MANUFACTURER'S GUIDELINES. DO NOT USE THIS FORK TRUCK ATTACHMENT IF LOAD WILL EXCEED FORK TRUCK MANUFACTURER'S LOAD CENTER RATING.

APPROX. WEIGHT/ LOST LOAD= 805.31 LBS.
FOR FORKS LONGER THAN 50"
EFFECTIVE THICKNESS= FORK LENGTH MINUS 49 1/4"
FOR FORK LENGTHS 48" OR SHORTER
MINIMIUN EFFECTIVE THICKNESS= LESS THAN 1"

DIMENSION TOLERANCE ± 1/4"

STANDARD FEATURES

- MODEL NUMBER: C-HOP-200
- CAPACITY: 2,000 LBS.
- VOLUME: 2 CUBIC YARDS
- OVERALL WIDTH: 60 5/8"
- OVERALL LENGTH: 57 1/4"
- OVERALL HEIGHT: 67 1/4"
- FORK POCKETS: 7 3/4" W x 2 3/4" H
- USABLE ON 30" CENTERS
- FORK POCKETS LENGTH: 49 1/4"
- PULL CABLE RELEASE
- AUTOMATIC DOOR RETURN AND LATCH
- SAFETY CHAIN TO SECURE TO TRUCK
- DURABLE LIQUID PAINT BLUE FINISH

SPECIAL FEATURES

NONE

APPROVAL

I, THE UNDERSIGNED, AGREE THAT THE PRODUCT AS REPRESENTED SATISFIES DESIGN AND DIMENSION REQUIREMENTS. I ALSO ACKNOWLEDGE MY DUTY TO CONFIRM PRODUCT AND INSTALLATION COMPLIANCE WITH ALL APPLICABLE FEDERAL, STATE AND LOCAL REGULATIONS AND STANDARDS.
UNITS REQUIRING APPROVAL DRAWINGS OR MODIFIED ARE NON-RETURNABLE
[] As drawn [] As marked

Signed: _____ Date: _____

Printed Name: _____

LEAD TIME WILL START UPON RECEIPT OF SIGNED APPROVAL DRAWING

DISTRIBUTOR'S NAME:		P.O.#
VESTIL MANUFACTURING		X
DRAWN BY: WS	DATE: 3/31/2008	W.O.#
REFERENCE: X	SCALE: 1:20	X
QUOTED LEAD TIME: X	QUOTE #	SALES: X
	X	FILE NAME:
		37-007-045