

Please read and save these instructions. Read through this owner's manual carefully before using product. Protect yourself and others by observing all safety information, warnings, and cautions. Failure to comply with instructions could result in personal injury and/or damage to product or property. Please retain instructions for future reference.



Stainless Steel Industrial Hose Reel ½"

Description

Speedaire Stainless Steel Industrial Hose Reels are ideal for food processing, pre-rinse, wash down, chemical transfer and industrial solvent handling. They have an internal spring for automatic hose rewind and a locking ratchet to maintain desired hose position while in use.

Unpacking

After unpacking the unit, inspect all components for any damage that may have occurred in transit. Read the following precautions and instructions before you begin assembly or using. Failure to comply with these instructions could result in personal injury or property damage. Keep these instructions in a convenient location for future reference.



Specifications and Dimensions

Model	Maximum Operating Pressure (PSI)	Hose Dimensions		Hose Reel Dimensions			Weight (Pounds)	Hose Outlet Connection NPT Male (Inch)	Reel Inlet Connection NPT Female (Inch)	Maximum Operating Temperatures (Fahrenheit)
		ID (Inch)	Length (Feet)	Length (Inch)	Width (Inch)	Height (Inch)				
2CUD4	300	1/2	50	20.6	8.4	22.5	53.0	1/2	1/2	210

General Safety Information

1. Make sure incoming line pressure does not exceed maximum rated operating pressure for your model hose reel.
2. Use proper eye protection when assembling and using the hose reel.
3. Remove all spring tension before beginning disassembly (Refer to Page 3 – hose replacement).
4. Keep children away from the work area, a recoiling hose has surprising force.
5. Never let the hose retract without holding on to it.

Throughout this manual the following symbols have these special meanings.

NOTE: Indicates special instructions which are important but not related to hazards.

▲ CAUTION

Warns about hazards that may cause minor personal injury or property damage if ignored.

▲ WARNING

Warns about hazards that can cause serious personal injury, death, or major property damage if ignored.



Stainless Steel Industrial Hose Reel 1/2"

Installation

Installation of Reel

1. For ceiling mounting: install reel at least 10 feet above the floor.
2. You will need to purchase appropriate hardware for your specific reel mounting configuration.
3. The reel base has four 1/2" (12.7mm) drilled holes for mounting on a suitable flat surface. Figure 2 on Page 5 is a template showing the correct location of the 4 mounting holes in the base.
4. The reel is supplied with a hose guide roller bracket. The bracket position may require repositioning depending on the selected reel mounting position. Figure 1 below shows "Typical Mounting Positions". If bracket position needs to be changed, do the following:
 - (a) Pull out some hose and let reel latch.
 - (b) Remove the bolts that attach the guide roller bracket to the support post.
 - (c) Rotate hose guide roller bracket to correct position, replace bolts and tighten.
5. Using all four holes in the base, mount the reel in the desired location. Be sure to use appropriate hardware (not included), and tighten securely.
6. Apply pipe sealant to threads on reel supply line, attach line to reel inlet and tighten.

▲WARNING Only use flexible hose to connect reel inlet. Do not use rigid plumbing.
7. Apply pipe sealant to outlet fitting of hose, then attach to desired tool, nozzle, or quick connect fitting.
8. Use soapy water to check connection for leakage, also check hose reel for correct operation, (Refer to Page 3 – Operation Section).
9. If hose stopper adjustment is required, pull hose from reel and allow latching at desired storage length. Loosen stopper bolts and slide stopper to a position close to the hose guide roller bracket. Tighten stopper bolts, and unlatch the reel.

FIGURE 1 Reel Mounting Positions

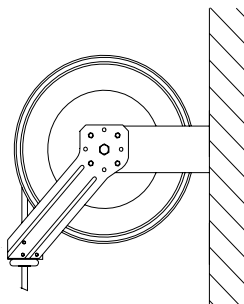

Wall

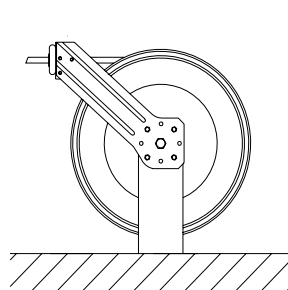

Floor

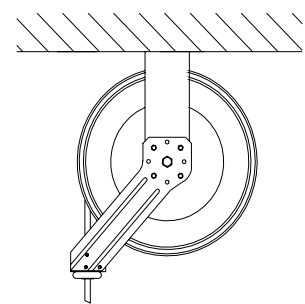

Ceiling



Stainless Steel Industrial Hose Reel ½”

Operation

1. Check reel for correct operation by slowly pulling out the hose. A “clicking” noise will be heard three times every half revolution of the drum.
2. To latch the reel, pull out the hose and allow it to retract after hearing the first, second, or third “click”.
3. To unlatch the reel, slowly pull out the hose until the “clicking” noise stops about ½ of a revolution, and then let the hose retract until the hose stop rests against the hose guide.

▲ CAUTION To avoid damage to the reel or personal injury always hold on to the hose while it is rewinding.

4. Periodically check the hose condition for wear or damage and check the swivel fitting for leakage. Replace any worn, damaged, or leaking parts.

Maintenance and Repair

Spring Tension Adjustment

If reel will not wind hose up completely it may be necessary to adjust the tension of the spring.

1. Pull out approximately 6 ft. (2 m) of hose and allow the drum to latch.
2. Remove hose stopper from hose and feed hose back through guide.
3. Wrap the pulled hose one time around the drum to **increase** tension or unwrap hose one time to **decrease** tension.
4. Reinsert hose through guide and install hose stopper onto hose end. Securely tighten hose stopper bolts.
5. Unlatch the drum and check tension. Pull hose from reel and adjust stopper position if necessary.

▲ CAUTION The spring tension can spin the reel quickly and with force.

Swivel Seal Replacement

1. Turn off air supply and carefully release pressure in hose. Disconnect supply line from swivel inlet.
2. Remove swivel assembly from reel axle.
3. Remove retainer from swivel and take apart. **NOTE:** You may want to remove swivel from reel hose end but this is not necessary unless a new swivel is being installed.
4. Replace the seals and reassemble swivel.
5. Use thread sealant on swivel thread fitting, reconnect the swivel thread fitting with axle.
6. Reconnect inlet supply line.

Hose Replacement

1. Turn off air supply to reel and carefully release pressure in hose.
2. Securely stabilize the reel by mounting or clamping to work surface.
3. Pull out all the old hose and lock the reel in this position.

▲ CAUTION Make sure reel drum is securely locked by letting ratchet teeth engage.



Stainless Steel Industrial Hose Reel 1/2"

Replacement of Hose (continued)

4. Remove the two hose clamps connecting the hose to the reel.
5. Carefully disconnect hose from the swivel joint on the side of the reel and discard old hose.
6. Feed new hose through guide and opening in drum, use sealant and connect to swivel. Reuse hose clamps on inside and outside of drum flange to reconnect hose.
7. Securely install stopper on other end of hose in the same position as before. Adjustments can be made later.

▲ WARNING Notice direction of the red arrow label on reel. It shows the rotation direction when the reel is rewinding.

8. Carefully release the drum latch, and while securely holding hose, slowly allow the hose to wind onto the reel.

NOTE: Final spring adjustment is accomplished by adding or removing wraps of hose around the drum. (Refer to Page 3 – Spring Tension Adjustment).

▲ WARNING The rewind spring is not serviceable. Do not remove spring cover.

PREVENTATIVE MAINTENANCE

Inspect normal wear items (plastic rollers, rubber stop, etc.) periodically for possible replacement.

LIMITED ONE YEAR WARRANTY

Should a Speedaire Hose Reel fail to perform satisfactorily due to defect or poor workmanship within one year of purchase, return it to your place of purchase and it will be replaced or repaired free of charge. Incidental or consequential damages are excluded from this warranty.



Stainless Steel Industrial Hose Reel 1/2"

FIGURE 2 - Base Template

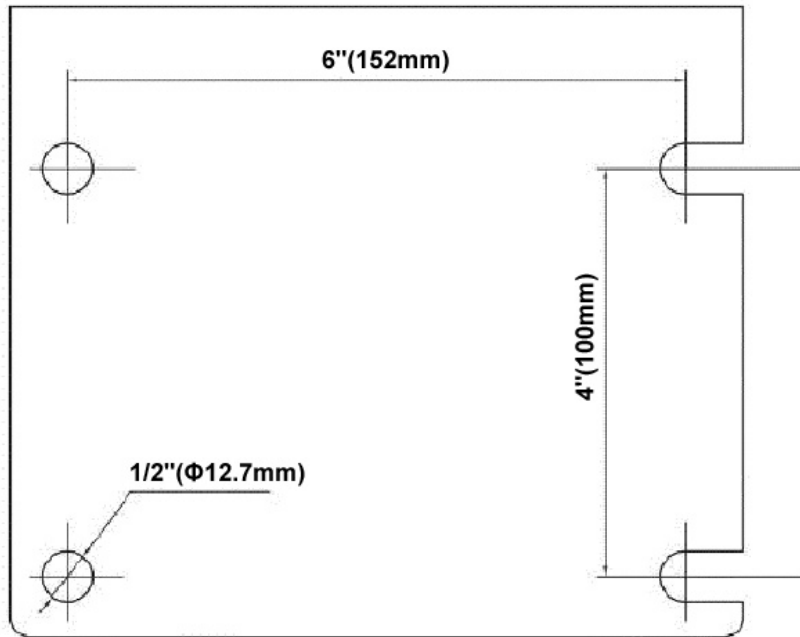

Template is not drawn to scale



Stainless Steel Industrial Hose Reel 1/2"

For Replacement Parts, call 1-800-323-0620

24 hours a day – 365 days a year Please provide the following:

- Model Number
- Serial Number (if any)
- Part description and number as shown on parts list

Repair Parts List

Reference Number	Description	Kit Components	Part Number	2CUD4
1	Swivel Assembly 1/2"	(1) Swivel Spool (1) Swivel Body (2) O-Rings (2) Ring Retainers (1) Retainer	2CUD4-1	X
2	Swivel O-Ring Kit – 1/2"	(2) O-Rings (2) Ring Retainers (1) Retainer	2CUD4-2	X
3	Stopper Assembly – 3/8"	(2) Bumper Blocks (2) Screws (2) Nuts	2CUD4-3	X
4	Spring Latch	(1) Spring Latch	2CUD4-4	X
5	Roller Assembly	(4) Roller Axles (4) Rollers	2CUD4-5	X



Stainless Steel Industrial Hose Reel 1/2"

