

Installation Instructions

8344.212

Exposed Wall Mount Sink Faucet with Top Brace

Thank you for selecting American-Standard... the benchmark of fine quality for over 100 years.

To ensure that your installation proceeds smoothly—please read these instructions carefully before you begin.

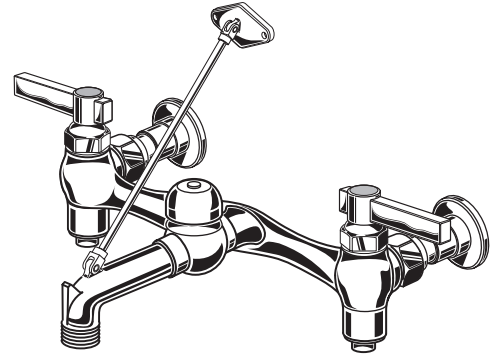

Certified to comply with ANSI A112.18.1M

M965443 REV. 1.2

RECOMMENDED TOOLS



Channel Locks



Adjustable Wrench



3/8" Socket Wrench



Sealing Tape

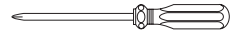

Phillips Screwdriver

ROUGHING-IN DIMENSIONS

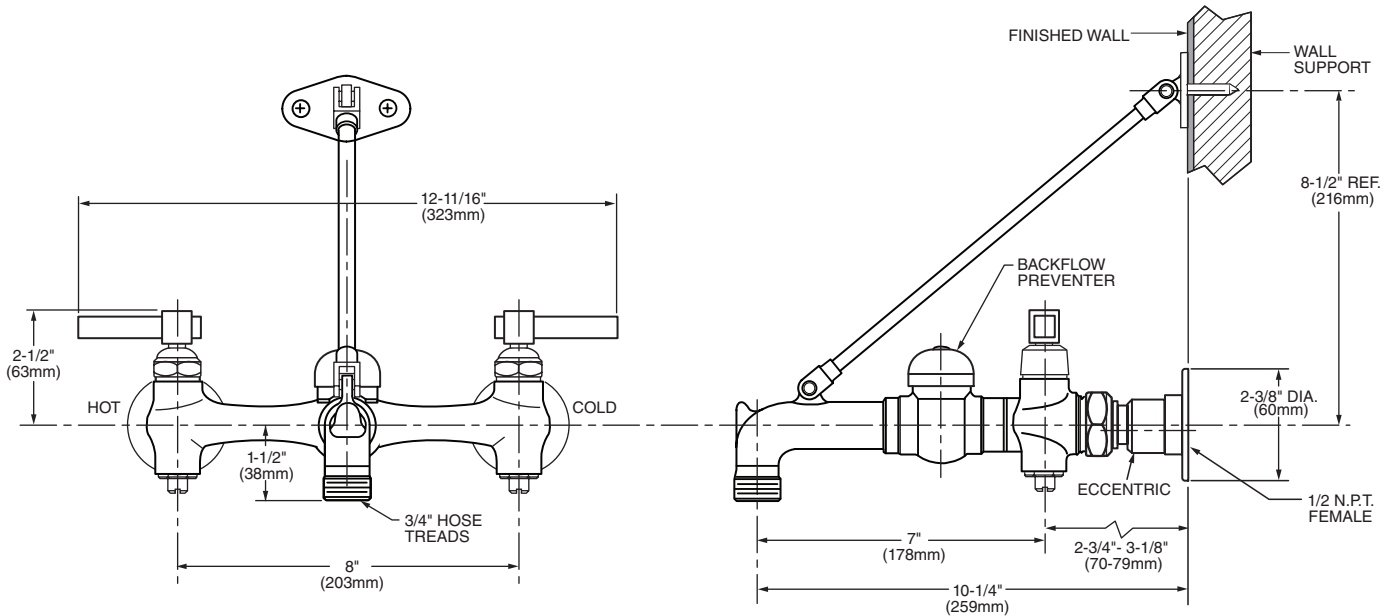

1 ROUGH-IN

- Prepare water supply lines per "Roughing-in Dimensions". Install 1/2" NPT. SUPPLY NIPPLES.

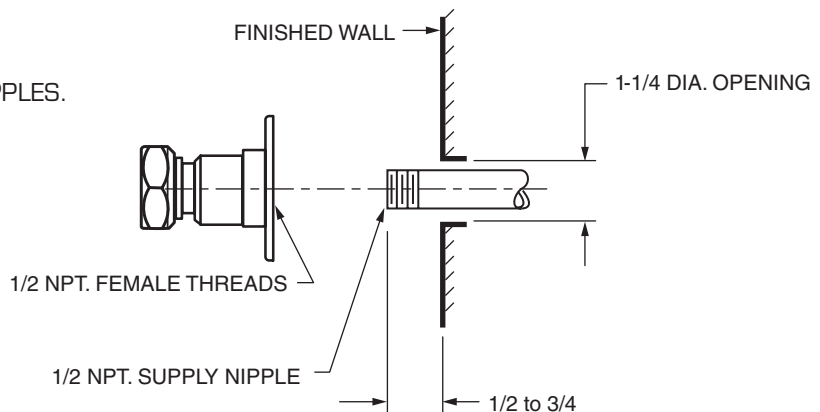

2 FINISH INSTALLATION

- Thread ESCUTCHEONS (1) fully onto INLET SHANK ECCENTRICS (2). **Fig. A**
- Apply Sealing Tape to threads of SUPPLY NIPPLES (3). **Fig. A**
- Thread INLET SHANK ECCENTRICS (2) onto SUPPLY NIPPLES (3) with a 3/8" socket wrench. **Fig. A**
- Distance between INLET SHANKS (3) outlets must be 8" to align with the FAUCET inlets. **Fig. B**
- Insert RUBBER WASHERS (4) into COUPLING NUTS (5). **Fig. B**
- Attach COUPLING NUTS (5) to VALVE (6). Tighten both COUPLING NUTS (5) firmly. **Fig. B**
- Thread ESCUTCHEONS (1) tight against finished wall. **Fig. B**

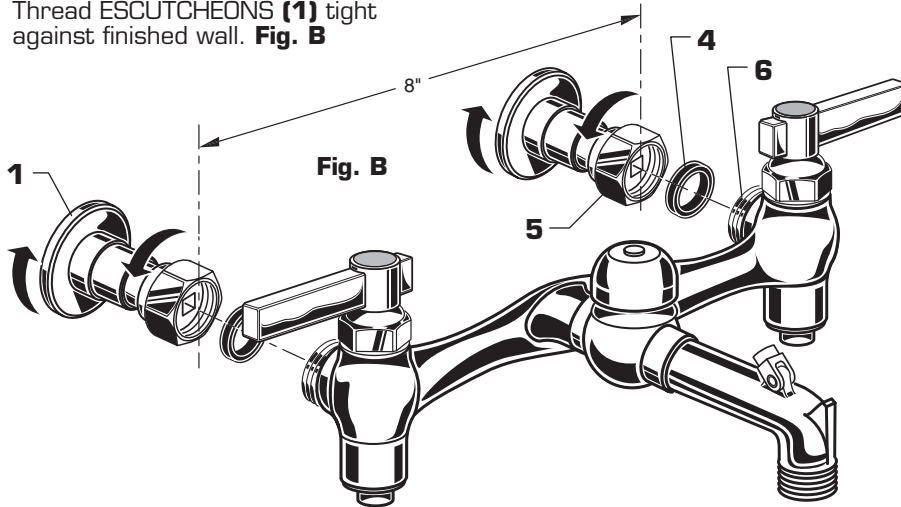
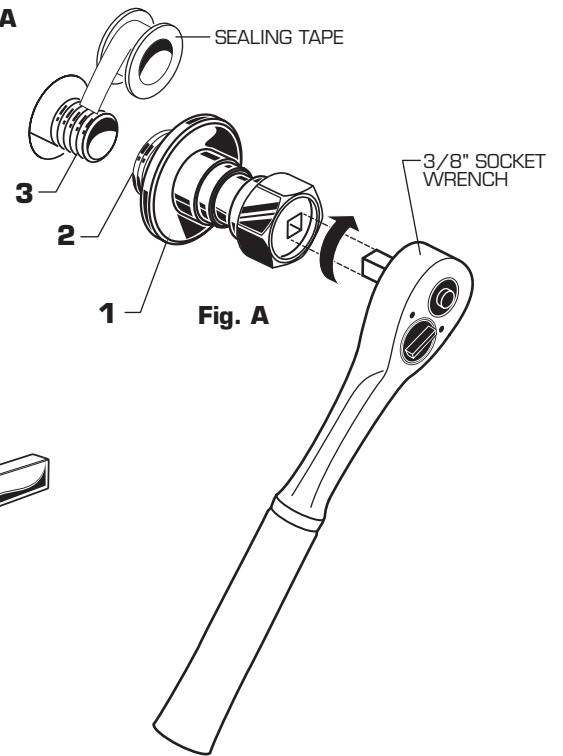

3 ATTACH SPOUT BRACE

- Attach SPOUT BRACE ASSEMBLY (1) to SPOUT HINGE (2). Align MOUNTING PLATE (3) against the wall and mark the two mounting holes.
- IF WALL MOUNTING PLATE (3) is not fastened to a wall support within the wall, use wall anchors with MOUNTING SCREWS.

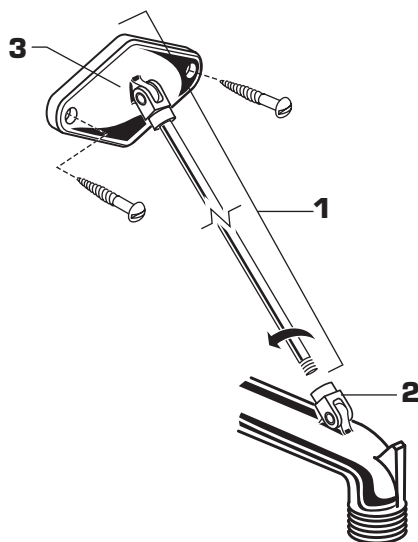

4 TEST FAUCET

- Turn HANDLES TO **OFF** POSITION.
- Slowly turn water supplies on and check all connections for leaks.
- Operate HANDLES to flush water lines thoroughly.
- Turn HANDLES to **OFF** position.

If spout drips, operate handles several times from OFF to ON position. Do not force - handles turn only 90°.

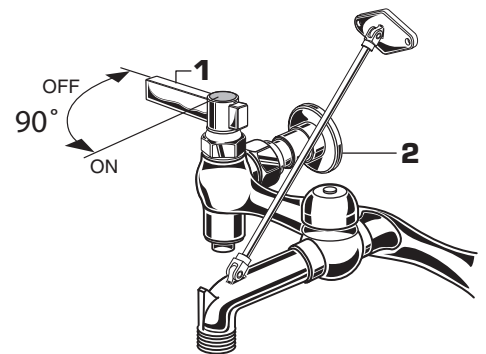

CARE INSTRUCTIONS:

DO: SIMPLY RINSE THE PRODUCT CLEAN WITH CLEAR WATER. DRY WITH A SOFT COTTON FLANNEL CLOTH.
DO NOT: DO NOT CLEAN THE PRODUCT WITH SOAPS, ACID, POLISH, ABRASIVES, HARSH CLEANERS, OR A CLOTH WITH A COARSE SURFACE.