



## S03, S05 Series Spring Return Direct Coupled Actuators

MS8103, MS4103, MS7503, MS7403, MS8105, MS4105, MS7505, MS7405

### INSTALLATION INSTRUCTIONS

MS8103, MS4103, MS7503, MS7403, MS8105, MS4105, MS7505, MS7405 Spring Return Direct Coupled Actuators (DCA) are used within heating, ventilating, and air-conditioning (HVAC) systems. They can drive a variety of quarter-turn, final control elements requiring spring return fail-safe operation.

Applications include:

- Volume control dampers, mounted directly to the drive shaft or remotely (with the use of accessory hardware).
- Quarter-turn rotary valves, such as ball or butterfly valves mounted directly to the drive shaft.
- Linear stroke globe or cage valves mounted with linkages to provide linear actuation.

### SPECIFICATIONS

**Models:**

- See Table 1.

**Device Weight:**

- 3.5 lbs (1.60 kg)

**Ambient Operating Temperature:**

- -40° to 150°F (-40° to 65°C)
- -22° to 150°F (-30° to 65°C) (Two position only)

**Shipping and Storage Temperature:**

- -40° to +150°F (-40° to +65°C) for 24 hours

Table 1. Models.

OS#	Torque	Control Signal	Power Supply and Frequency	Switch	Drive Timing	VA Driving
MS8103A1030/U	27 lb-in (3 Nm)	Two Position SPST	24Vac @ 50/60 Hz, +/-20% 24Vdc +/-10%	0	45 sec	7 VA
MS8103A1130/U			24Vac @ 50/60 Hz, +/-20% 24Vdc +/-10%	1	45 sec	7 VA
MS4103A1030/U			120/230 Vac @ 50/60 Hz, +/-10%	0	45 sec	10 VA
MS4103A1130/U			120/230 Vac @ 50/60 Hz, +/-10%	1	45 sec	10 VA
MS7503A2030/U		(0)2-10 Vdc, Floating	24Vac @ 50/60 Hz, +/-20% 24Vdc +/-10%	0	90 sec	7 VA
MS7503A2130/U			24Vac @ 50/60 Hz, +/-20% 24Vdc +/-10%	1	90 sec	7 VA
MS7403A2030/U		2-10, Floating, Economizer (3 kOhm, 3-Position)	24Vac @ 50/60 Hz, +/-20% 24Vdc +/-10%	0	90 sec	7 VA
MS8105A1030/U		44 lb-in (5 Nm)	Two Position SPST	24Vac @ 50/60 Hz, +/-20% 24Vdc +/-10%	0	45 sec
MS8105A1130/U	24Vac @ 50/60 Hz, +/-20% 24Vdc +/-10%			1	45 sec	8 VA
MS4105A1030/U	120/230 Vac @ 50/60 Hz, +/-10%			0	45 sec	11 VA
MS4105A1130/U	120/230 Vac @ 50/60 Hz, +/-10%			1	45 sec	11 VA
MS7505A2030/U	(0)2-10 Vdc, Floating		24Vac @ 50/60 Hz, +/-20% 24Vdc +/-10%	0	90 sec	8 VA
MS7505A2130/U			24Vac @ 50/60 Hz, +/-20% 24Vdc +/-10%	1	90 sec	8 VA
MS7405A2030/U	2-10, Floating, Economizer (3 kOhm, 3-Position)		24Vac @ 50/60 Hz, +/-20% 24Vdc +/-10%	0	90 sec	8 VA



**Humidity Ratings:**

- 5% to 95% R.H., Non-Condensing

**Electrical Connections:**

- Field wiring 18 AWG (0.5 mm) to 14 AWG (1.5 mm) conductors (stranded or solid) and up to 2 - 14 AWG (1.5 mm) conductors (stranded) to screw terminals, located under the removable access cover.

**Auxiliary Switch (One SPDT):**

- Switch adjustable from 0-95°
- 500 uA Resistive at 5 Vdc (minimum)
- 250 Vac, 8 A resistive, 3 A inductive

**Mounting: Self-centering shaft adapter (shaft coupling):**

- Round damper shafts: 3/8 to 5/8 in. (9 to 16 mm)
- Square damper shafts: 1/4 to 1/2 in. (6 to 13 mm)

**Minimum Damper Shaft Length:**

- 1 in. (25 mm); 3 in.(76 mm) recommended.

**Spring Return Timing (at rated load):**

- < 25 seconds @ -4°F to 130°F (-20°C to 55°C)
- < 60 seconds @ -22°F (-30°C)

**Enclosure Ratings:**

- IP54
- NEMA 2
- Flame Resistance UL94-5VA

**Input Impedance:**

- 95 kOhms minimum.

**Feedback Signal:**

- 0(2)-10 Vdc, 3 mA minimum.

**Noise Rating at 1m (Maximum):**

- Driving
  - Floating/Modulating/Econ: < 40 dB(A)
  - 2-Position: < 50 dB(A)
- Spring Return: < 60 dB(A)

**Accessories:**

- 27518 Balljoint (5/16 in.)
- 103598 Balljoint (1/4 in.)
- 27520A-E,G,H-L,Q Pushrod (5/16 in. diameter)
- STRN-STRNRLF Water-tight Cable Gland/Strain-relief Fitting (10 pack)
- STRN-WMK-01 Wall Mount Kit
- STRN-ECONO-01 Economizer Retrofit Kit
- STRN-CRK-01 Crank Arm Kit
- STRN-SCSA Self Centering Shaft Adapter
- STRN-CA-01 Crank Arm (Non-Self-Centering)
- STRN-CA-02 Crank Arm (Self-Centering)
- STRN-BRKT Anti-Rotation Bracket

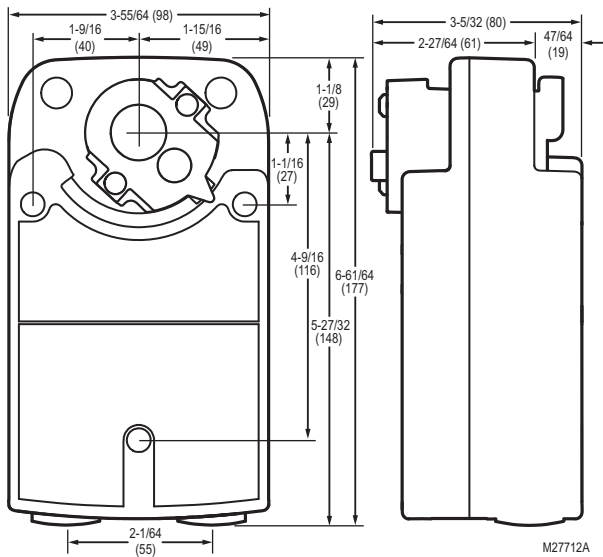

Fig. 1. Dimensional drawing of actuator in in. (mm).

**Stroke:** 95° ±3°, mechanically limited.

**Approvals:**

- UL873
- IEC 60730-1 and Part 2-14
- UL1097 for Double Insulation
- CE Certification Low Voltage Directive 2006/95/EC
- CE EMC 2004/108/EC
- C-Tick N314

**TYPICAL SPECIFICATION**

Spring return actuators shall be direct coupled type requiring neither crankarm nor linkage and be capable of direct mounting to a jackshaft of up to 5/8 in. diameter. The actuator shall connect to the shaft using a removable output hub with a self-centering shaft coupling. This coupling shall provide concentric mounting and include an integral adjustable range-stop mechanism.

The actuator shall provide two-position, floating, or proportional control. Proportional control refers to direct acceptance of 0-10 Vdc, 2-10 Vdc, or (with addition of a 500 ohm resistor) a 4-20 mA input signal. Proportional and floating control models shall provide a feedback signal. Actuators shall provide wiring terminals located within an integral access cover with conduit connections. Proportional and floating actuators shall have a rotation direction control switch accessible on the cover.

All spring return actuators must be designed for either clockwise or counterclockwise fail-safe operation with a continuously engaged mechanical spring. This spring must return the valve or actuator to a fail-safe position within 25 seconds of power loss.

All actuators shall be designed for a minimum of 60,000 fullstroke cycles at rated torque and temperature, 60,000 springreturn cycles and 1,500,000 repositions. Run time shall be constant and independent of: load, temperature, and supply voltage (within specifications). All actuators shall be UL60730 and cUL (CSA22.2) listed, have a five year warranty, and be manufactured under ISO 9001 International Quality Control Standards. Actuators shall be as manufactured by Honeywell.

# INSTALLATION

## When Installing this Product...

1. Read these instructions carefully. Failure to follow them could damage the product or cause a hazardous condition.
2. Check the ratings given in the instructions and on the product to make sure the product is suitable for your application.
3. Installer must be a trained, experienced service technician.
4. After installation is complete, check out product operation as provided in these instructions.

### CAUTION

**Electrical Shock or Equipment Damage Hazard.**  
**Low voltage can shock individuals or short equipment circuitry.**  
 Disconnect power supply before installation.

### IMPORTANT

*All wiring must agree with applicable codes, ordinances and regulations.*

## Location

These actuators are designed to mount directly to a damper external drive shaft. The shaft coupling fastens to the drive shaft. The actuator housing includes slots which, along with an anti-rotation bracket, secure the actuator to the damper frame or duct work (see Fig. 7).

### NOTES:

- When mounted correctly, these slots allow the actuator to *float* without rotating relative to the damper shaft.
- Using other brackets or linkages, the actuator can be foot-mounted or tandem-mounted.

### CAUTION

**Motor Damage Hazard.**  
**Corrosive vapors and acid fumes can damage metal and plastic parts.**  
 Install motor in areas free of acid fumes and other deteriorating vapors.

### CAUTION

**Equipment Damage Hazard.**  
**Tightly securing actuator to damper housing can damage actuator.**  
 Mount actuator to allow it to float along its vertical axis.

## Preparation



Before mounting the actuator onto the damper shaft, determine the:

- Damper/valve opening direction for correct spring return rotation. The actuator can be mounted to provide clockwise

or counterclockwise spring return by flipping or turning the unit over.

- Damper shaft size (see the Specifications section).

## Determine Appropriate Mounting Orientation

The actuators are designed to open a damper by driving the damper shaft in either a clockwise  or counterclockwise  direction (see Fig. 2).

### NOTES:

- Actuators are shipped in the fully closed (spring return) position.
- An arrow on the hub points to a location on the label to indicate the hub rotary position.

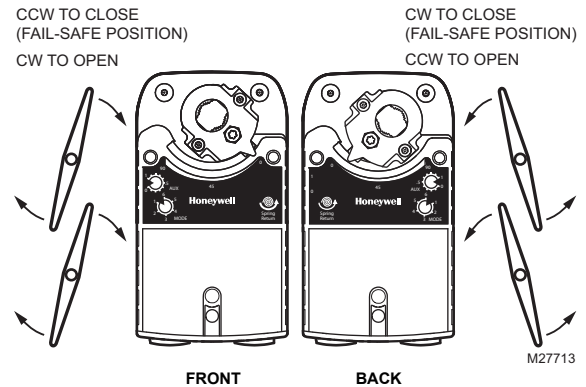

**Fig. 2. Spring Return DCA mounting orientation.**

## Measure Damper/Valve Shaft Length

If the shaft is less than three inches in length, the shaft coupling must be located between the damper/valve and actuator housing. If the shaft length is more than three inches, the shaft coupling may be located on either side of the actuator housing.

If the coupling must be moved from one side of the actuator to the other, reverse the spring return direction and flip the actuator. Follow these instructions (see Fig. 3):

1. Remove the retainer clip from the shaft coupling and set it aside for later use.
2. Remove shaft coupling from one side of the actuator.
3. Replace the shaft coupling on the opposite side of the actuator aligning it based on the stroke labeling.
4. Replace the retainer clip on the shaft coupling using the groove of the coupling.

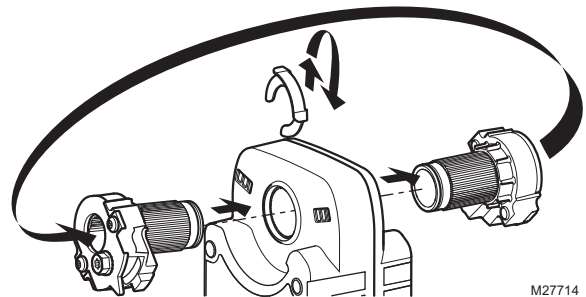

**Fig. 3. Mounting shaft coupling to actuator opposite side.**

## Selecting Actuator Control Signal

Selections are made using a dial that appears on both the front and back of the actuator (see Fig. 4).

To select the control signal simply turn the mode selection dial to the desired mode (as indicated on the device label) without exceeding range indicators.

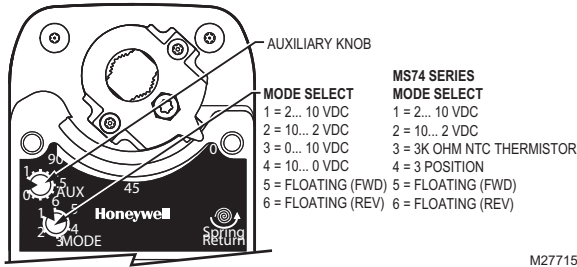

Fig. 4. Dials for control signal and switch or minimum position.

## Auxiliary Knob

The auxiliary knob can be used to control minimum position (MS74 Series) or switch position.

### SELECT MINIMUM POSITION (MS74 SERIES)

Minimum Position Potentiometer active in 3KOhm and 3 position modes only.

### SELECT SWITCH POSITION

For switch models, select the degree of rotation you want the switch to activate.

## Non-Standard Stroke

### Mechanical Stroke Limit Reduction

For applications requiring a span less than 95 degrees, a simple adjustment can be made. When the rotational mounting of the shaft coupling is changed, the actuator drives less than the full 90 degrees stroke.

The stroke is adjustable in 5 degree increments. Once adjusted, the actuator drives until the shaft coupling reaches the mechanical stop (part of the housing). The stop causes the motor to discontinue driving and the shaft coupling drives no farther. When the actuator returns, it stops at the fail-safe position.

To limit the stroke range, proceed as follows:

1. Remove the retainer clip from the shaft coupling and set it aside for later use.
2. Remove shaft coupling from the actuator.
3. Rotate the coupling to the desired position, aligning it based on the stroke labelling. See Fig. 5.

NOTE: The shaft coupling location determines the travel span.

EXAMPLE: Setting shaft coupling to an approximate fail-safe position of 35 degrees (as indicated on the housing) limits stroke to 60 degrees. (See Fig. 5)

4. Install the shaft coupling at this position.
5. Replace the retainer clip on the shaft coupling using the groove of the coupling.

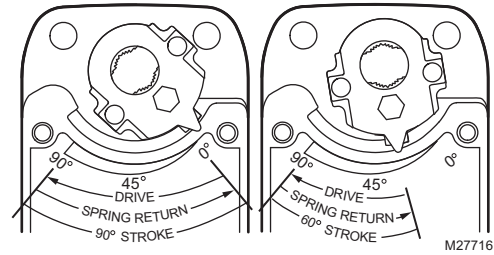

Fig. 5. Stroke reduction.

## Mounting



### CAUTION

**Device Malfunction Hazard.**

**Improper shaft coupling tightening causes device malfunction.**

Tighten shaft coupling with proper torque to prevent damper shaft slippage.



### CAUTION

**Actuator Damage Hazard.**

**Using actuator as shaft bearing causes device damage.**

Use actuator only to supply rotational torque. Avoid any side loads to actuator output coupling bearings.



### CAUTION

**Equipment Damage Hazard.**

**Can damage the motor beyond repair.**

Never turn the motor shaft by hand or with a wrench. Forcibly turning the motor shaft can damage the gear train.

To mount the actuator to an external drive shaft of a damper, proceed as follows:

1. Place actuator over damper shaft; and hold mounting bracket in place. See Fig. 7.
2. Mark screw holes on damper housing.
3. Remove actuator and mounting bracket.
4. Drill or center-punch holes for mounting screws (or use no.10 self-tapping sheet metal screws).
5. Turn damper blades to desired normal (closed) position.
6. Place actuator and mounting bracket back into position and secure bracket to damper box with sheet metal screws.
7. Using 10 mm wrench, tighten shaft coupling securely onto damper shaft using maximum 240 lb-in. (27.1 Nm) torque.

NOTE: See Fig. 6 for proper mounting to a square damper shaft.

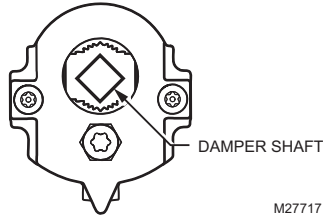

**Fig. 6. Proper mounting to square damper shaft.**

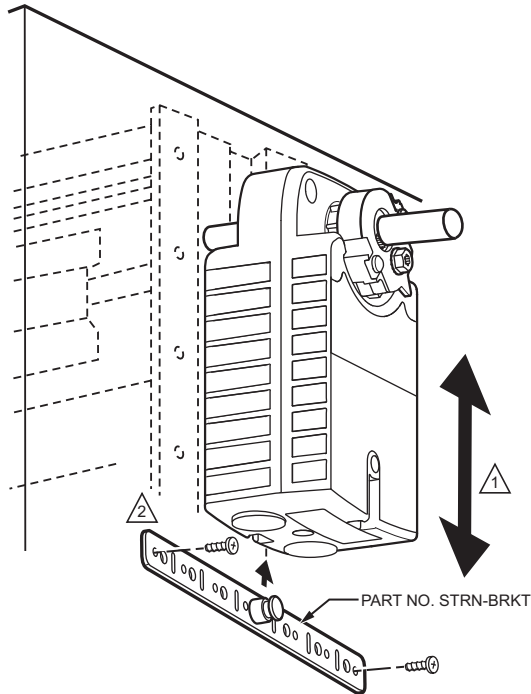

- ⚠️ ENSURE THAT MOUNTING ASSEMBLY PREVENTS ACTUATOR ROTATION AND ALLOWS ACTUATOR TO FLOAT ALONG INDICATED AXIS. WHEN TOO TIGHT, THE RESULTING BINDING CAN DAMAGE THE ACTUATOR OR REDUCE TORQUE OUTPUT.
- ⚠️ THE BRACKET CAN BE BENT TO ALLOW MOUNTING THE ACTUATOR PARALLEL TO THE MOUNTING SURFACE. M27718

**Fig. 7. Mounting actuator to damper housing.**

## WIRING



### CAUTION

**Electrical Shock or Equipment Damage Hazard. Disconnect all power supplies before installation.** Motors with auxiliary switches can have more than one disconnect.

#### IMPORTANT

*All wiring must comply with local electrical codes, ordinances and regulations.*

## Access Cover Removal (Fig. 8)



### CAUTION

**Equipment Damage Hazard.**

**Improper cover removal can damage electric connections.**

Pull the cover along the axis of the actuator.

The cover contains contact sockets that must connect to actuator contact pins.

Bending these pins can permanently damage the device.

NOTE: This cover can be removed before or after mounting actuator to the damper shaft or valve linkage.

In order to wire the device, the access cover must be removed as follows:

1. Remove the screw from the center of the cover, set the screw aside.
2. Pull the cover along the long axis of the actuator.
3. If the actuator is not yet mounted, set it aside.
4. Remove conduit dust covers.
5. Thread wire through conduit holes.
6. Connect wires as appropriate to the terminal block(s). (See Fig. 9 and 10.)

NOTE: Use either 1/2 in. x 14 NPS or M20 x 1.5 strain relief or conduit adapters.

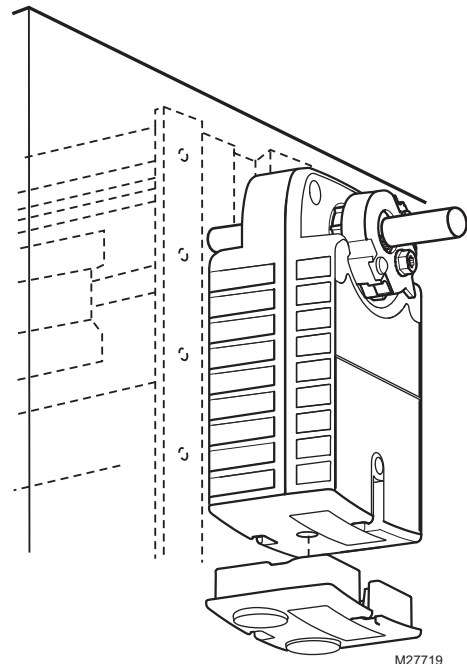

**Fig. 8. Removing access cover.**

## Typical Wiring

See Fig. 9 through 21 for typical wiring details.

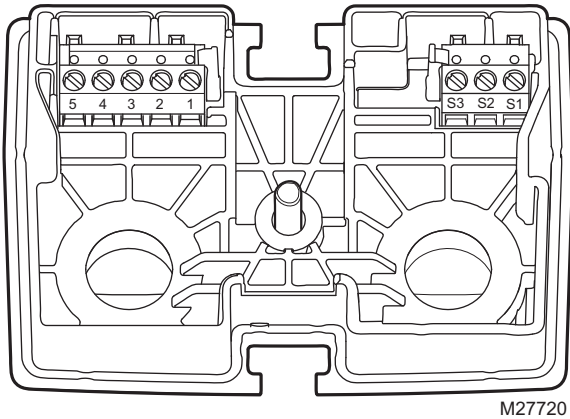

Fig. 9. Terminal block details.

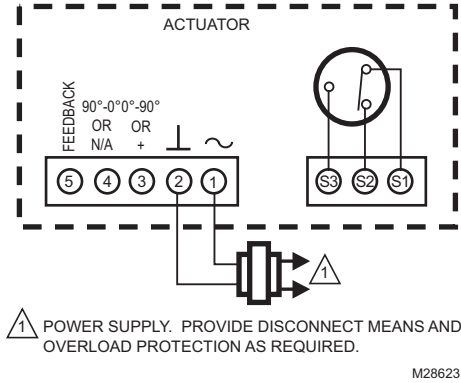

Fig. 10. Terminal block details.

Table 2. Wiring Details.

Terminal	Floating	Modulating	3 kOhm Economizer	3 Position Economizer	Two-Position	
					24Vac/Vdc	120–250 Vac
~ 1	power	power	power	power	power	power
⊥ 2	common	common	common	common	common	neutral
3	0°-90°	control signal	control signal	control signal	—	—
4	90°-0°	—	external minimum position potentiometer	external minimum position potentiometer	—	—
← 5	feedback	feedback	feedback	feedback	—	—

### Two-Position Models

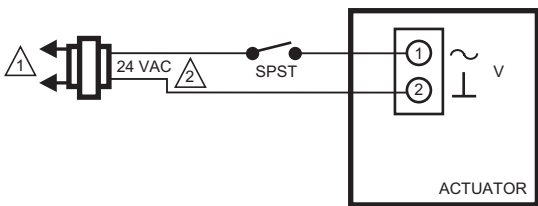

Fig. 11. Wiring for low-voltage two-position control.

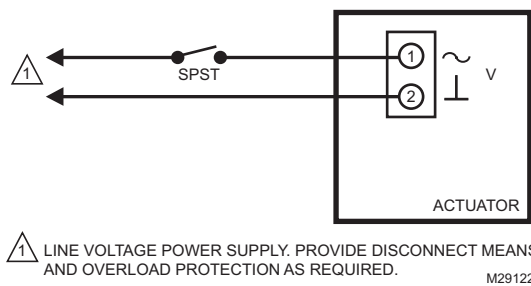

Fig. 12. Wiring for line-voltage two-position control.



Floating, Modulating, and Economizer Models

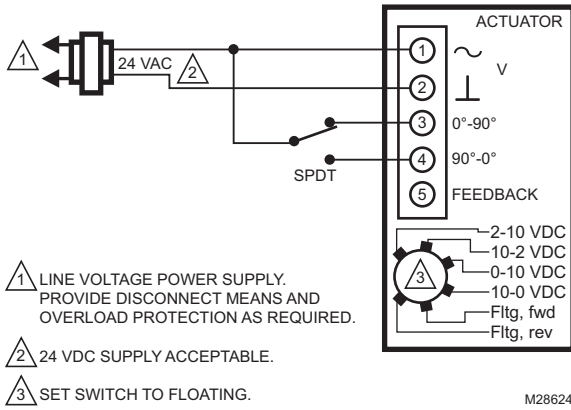

Fig. 13. Wiring for SPDT on/off control.

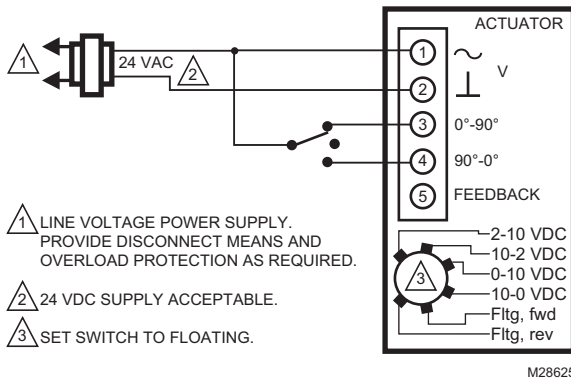

Fig. 14. Wiring for floating control.

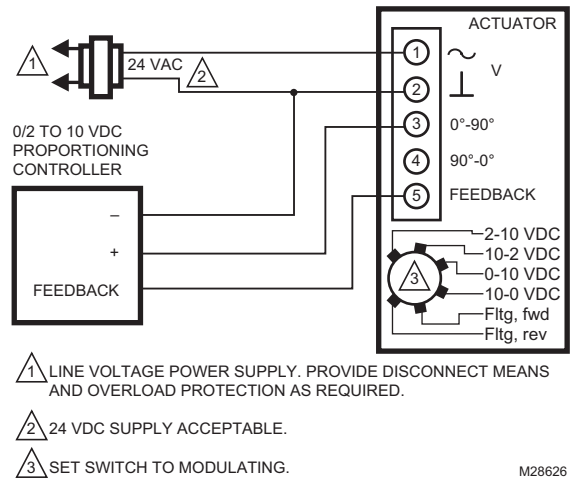

Fig. 15. Wiring for (0)2-10 Vdc proportioning controllers.

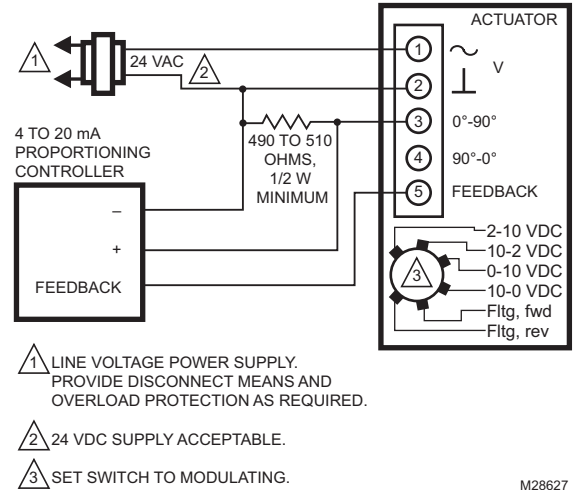

Fig. 16. Wiring for 4-20 mA proportioning controllers.

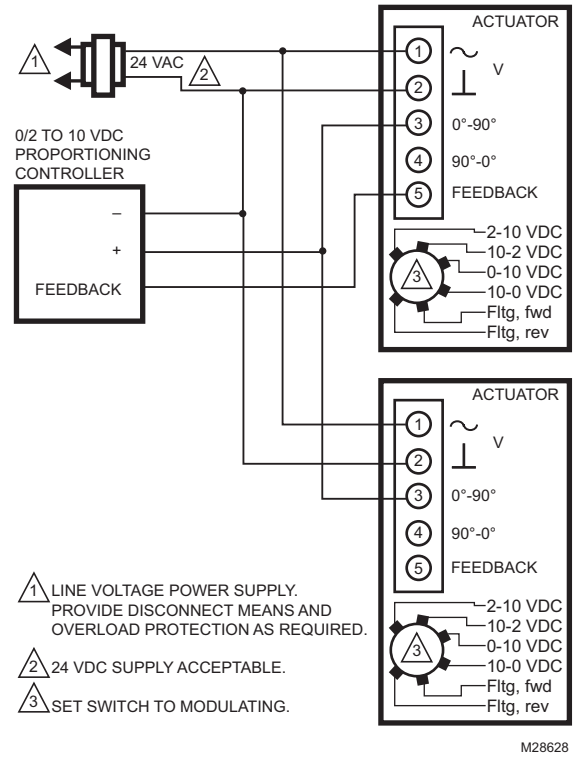

Fig. 17. Wiring for (0)2-10 Vdc proportioning controller operating multiple actuators.

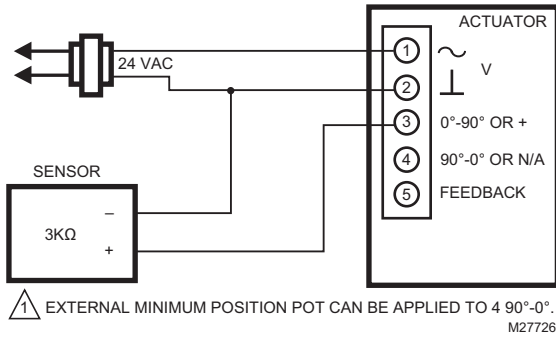

Fig. 18. Wiring for 3 kOhm Economizer controllers.

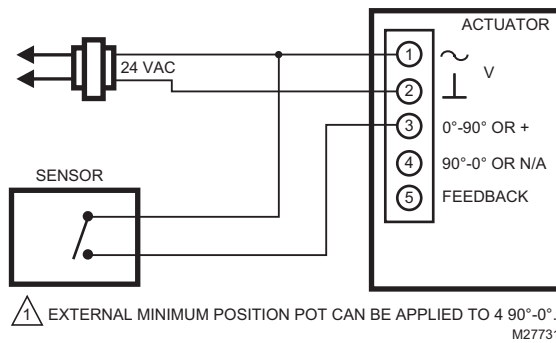

Fig. 19. Wiring for 3 position Economizer controllers.

## OPERATION

The actuator is designed to be used in ventilating and air conditioning installations to operate valves, dampers, ventilation flaps and louvers. (For ratings, see the Specifications section.) If the power fails, the actuator will spring return to the fail safe position.

When using a proportional controller, the actuator drives toward its fully open position when the input signal increases; the actuator drives toward the fully closed position when the input signal decreases. The actuator stops when the input signal reaches the desired proportional control point. This operates in reverse when set to a 10-2(0) position.

### IMPORTANT

*The actuator is designed to respond to DDC Controller instantaneous contact closures. Take care not to short cycle the actuator. Unstable damper control can cause premature actuator failure.*

### Actuator Override

To override the control signal (for freeze protection or similar applications):

1. Override to full open:
  - a. Disconnect the input signal (from terminal 3).
  - b. Apply 24 Vac to terminal 3.
  - c. See Fig. 20.
2. Override to full closed:
  - a. Disconnect the input signal (from terminal 3).
  - b. See Fig. 21.

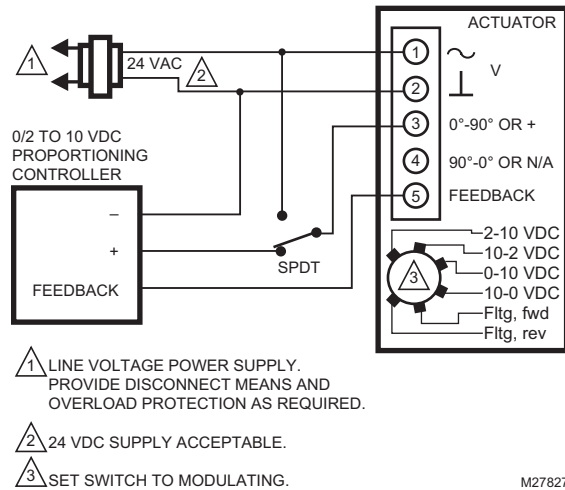

1 LINE VOLTAGE POWER SUPPLY. PROVIDE DISCONNECT MEANS AND OVERLOAD PROTECTION AS REQUIRED.

2 24 VDC SUPPLY ACCEPTABLE.

3 SET SWITCH TO MODULATING.

M27827

Fig. 20. Override to full open.

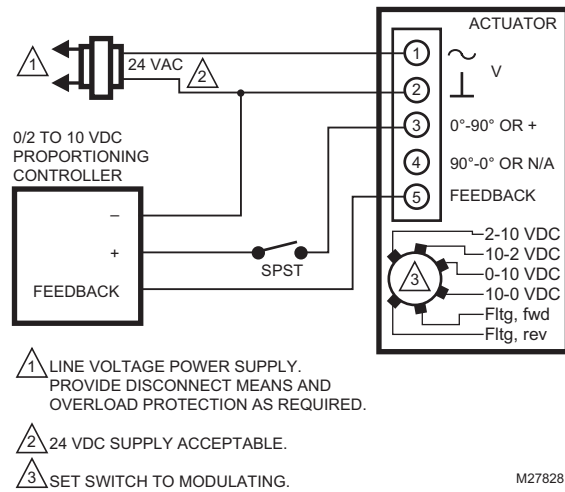

1 LINE VOLTAGE POWER SUPPLY. PROVIDE DISCONNECT MEANS AND OVERLOAD PROTECTION AS REQUIRED.

2 24 VDC SUPPLY ACCEPTABLE.

3 SET SWITCH TO MODULATING.

M27828

Fig. 21. Override to full close.

## End Switches

Some models include an adjustable end switch. For wiring details, see Fig. 10.

## CHECKOUT



### Modulating/Floating Operation

1. Mount actuator for required application (either clockwise or counterclockwise rotation to open the damper).
2. Connect power to terminals 1 and 2. (See Fig. 10 and Table 2.)
3. Set "Mode Select" dial to desired control signal. (See Fig. 4.)
4. Apply control signal for actuator full open or full closed position. (See Fig. 10 and Table 2.)
  - a. (0)2-10 Vdc: apply 10 Vdc signal to terminal 3.
  - b. 10-(0)2 Vdc: apply (0)2 Vdc signal to terminal 3.
  - c. (0)4-20 mA: apply 20 mA signal to terminal 3.



- d. 20-(0)4mA: apply (0)4 mA signal to terminal 3.
- e. Floating: apply 24 Vac to appropriate 0°-90° (3) or 90°-0° (4) terminal.
- 5. Actuator drives to full open or full closed position.
- 6. Apply control signal for actuator 0% position. (See Fig. 10 and Table 2.)
  - a. (0)2-10 Vdc: apply (0)2 Vdc signal to terminal 3.
  - b. 10-(0)2 Vdc: apply 10 Vdc signal to terminal 3.
  - c. (0)4-20 mA: apply (0)4 mA signal to terminal 3.
  - d. 20-(0)4mA: apply 20 mA signal to terminal 3.
  - e. Floating: apply 24 Vac to appropriate 0°-90° (3) or 90°-0° (4) terminal.
- 7. Actuator drives to full open or full closed position.

## Spring Return Operation





1. Mount actuator for required application (either clockwise  or counterclockwise  rotation to open the damper or valve).
2. Connect power to terminals 1 and 2. (See Fig. 10 and Table 2.)
 

NOTE: For two-position models skip to step 5.
3. Set "Mode Select" dial to desired control signal. (See Fig. 4.)
4. Apply control signal for actuator 50% position. (See Fig. 10.)
  - a. Vdc Input Signal: apply 5-6 Vdc signal to terminal 3.
  - b. mA Input Signal: apply 10-12 mA signal to terminal 3.
  - c. Floating: apply 24 Vac to appropriate 0°-90° (3) or 90°-0° (4) terminal until device reaches 50%.
5. Allow the actuator to drive to 50% position.
6. Disconnect wire from terminal 1.
7. Actuator spring returns to 0% position.
8. Re-connect wire to terminal 1, actuator drives back toward 50% position.



## Feedback Operation

1. Connect a multi-meter, set for Vdc, to terminals 2 and 5.
2. Apply the same signal as in step 4 of Modulating Operation.
3. The multi-meter reading increases to match the input signal as actuator drives towards full open or full closed position.
4. Apply the same signal as in step 6 of Modulating Operation.
5. The multi-meter reading decreases to match the input signal as actuator drives towards 0% position.

## Direct Checkout

1. Mount actuator for required application (either clockwise  or counterclockwise  rotation to open the damper or valve).
2. Check damper position and make sure that 24 Vdc/Vac is present at the appropriate connections. (See Fig. 9.)
3. Apply control signal to the appropriate connections to move the damper to the opposite position. The actuator should drive the damper or valve.
4. If actuator does not run, verify that the actuator is properly installed for either clockwise  or counterclockwise  rotation.
5. If actuator is correctly installed and still does not run, replace the actuator.

## Two-Position Checkout

1. Mount actuator for required application (either clockwise  or counterclockwise  rotation to open the damper or valve).
2. Check damper position and make sure that power is present at terminals 1 and 2.
3. Actuator drives to 100% position.
4. Disconnect power from terminals 1 and 2.
5. Actuator spring-returns to 0% position.

If actuator is correctly installed and does not run, replace the actuator.





**Automation and Control Solutions**

Honeywell International Inc.  
1985 Douglas Drive North  
Golden Valley, MN 55422  
customer.honeywell.com

Honeywell Limited-Honeywell Limitée  
35 Dynamic Drive  
Toronto, Ontario M1V 4Z9

