



R2100

Blowout Jet Toilet - Off Floor

Replacement Toilet for Most Vitreous China Closet Fixtures.

The **R2100** is designed to replace a variety of existing front mount wall-hung fixtures with 3-point mounting. Unit includes a contoured integral seat with satin finish in addition to punching for a hinged seat by others. Unit is fabricated from 16 gage, type 304 stainless steel and is seamless welded construction with exposed exterior & interior surfaces having a satin finish.

Toilet is Blowout Jet type with elongated bowl manufactured to comply with ASME A112.19.3-2008 and CSA B45.4-2008 standards. Toilet requires a minimum of 25 PSI flow pressure and uses a minimum water consumption of 1.28 gallons per flush. Trap has a minimum 3-1/2" seal, will pass a 2-1/8" ball and is fully enclosed. Toilet has a 1-1/2" NPT flushing inlet connection and a gasketed waste outlet.

GUIDE SPECIFICATION

Provide and install Acorn Replacement Blowout Jet Toilet (specify model number and options). Fixture shall be fabricated from 16 gage, type 304 stainless steel. Construction shall be seamless welded and exposed surfaces shall have a satin finish with an integral contoured toilet seat. Toilet shall be concealed blowout jet type with an elongated bowl and a self-draining flushing rim. Toilet shall be ASME A112.19.3-2008 and CSA B45.4-2008 compliant. Toilet requires a minimum of 25 PSI flow pressure and uses a minimum water consumption of 1.28 gpf. Toilet trap shall have a minimum 3-1/2" seal that shall pass a 2-1/8" diameter ball and be fully enclosed. Toilet waste outlet shall be a gasketed waste.



Must specify:

- R2100-T-1
- R2100-W-1

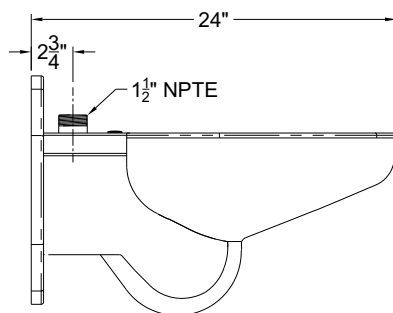

R2100-T-1

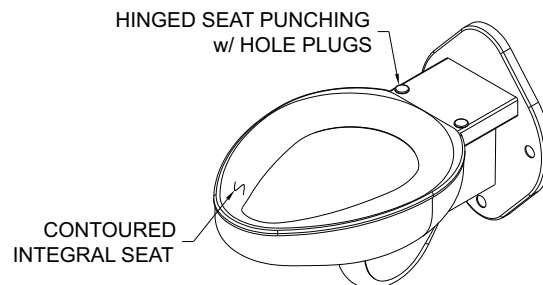

R2100-W-1
SHOWN

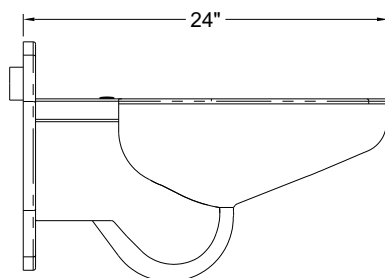

R2100-W-1

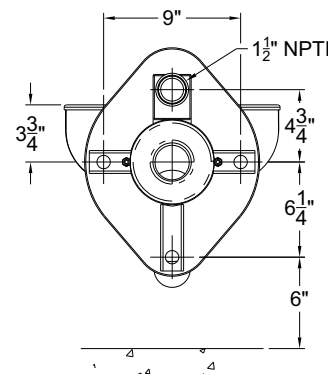

Please visit www.acorneng.com for most current specifications.

WARNING: Cancer and Reproductive Harm - www.P65Warnings.ca.gov