

NOTE:
BEFORE INSTALLING FIXTURE
ENSURE MOUNTING AND
CONNECTION DIMENSIONS MATCH.

IF A #2898 FLUSH VALVE ACCESS
PANEL (8) IS REQUIRED (FOR
CONCEALED FLUSH VALVES), INSTALL
SLEEVE. SEE DRAWING #9908-399-001.

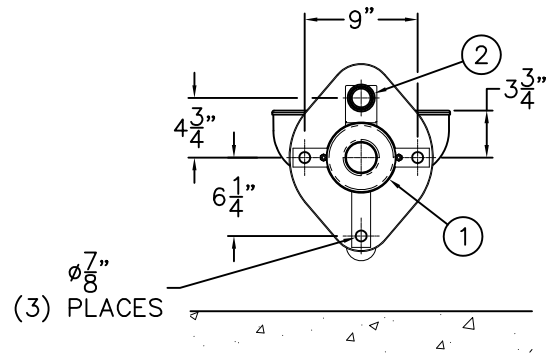
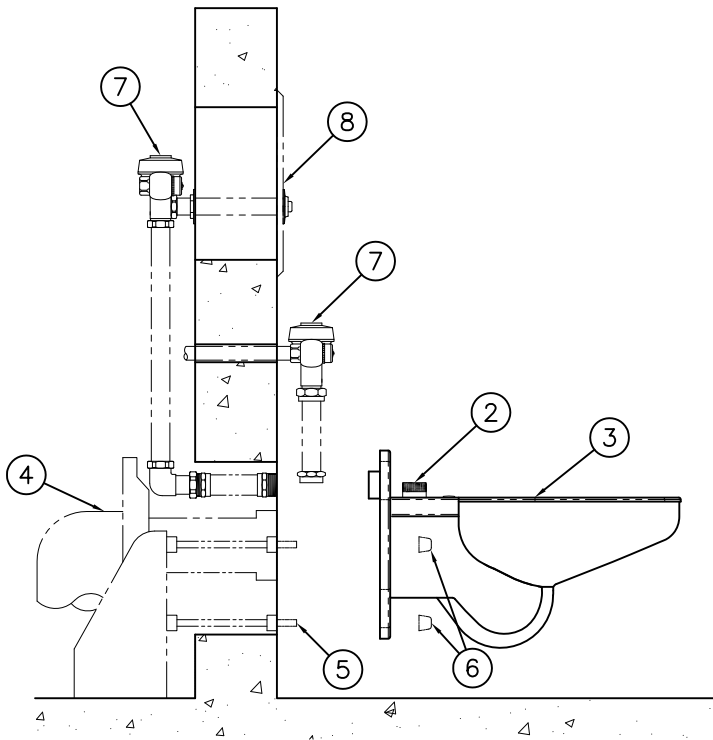

INSTALLATION INSTRUCTIONS:

A-DISCONNECT AND REMOVE EXISTING FIXTURE. CLEAN AND REMOVE ALL DEBRIS FROM WASTE CONNECTION (1) AND FLUSHING INLET CONNECTION (2).

B-ROUGH-IN FOR THE FOLLOWING:
5-1/2" DIA. GASKET WASTE (1).
1-1/2" NPT FLUSHING INLET CONNECTION (2).

C-MOUNT FIXTURE (3) TO EXISTING WALL CARRIER (4). PLACE ON EXISTING STUDS (5) AND SECURE WITH CAP NUTS (6) (BY OTHERS).

D-RECONNECT FLUSH VALVE (7).

ACORN ENGINEERING COMPANY
P.O. BOX 3527 INDUSTRY, CA. 91744
(626) 336-4561 FAX (626) 961-2200

TITLE **BLOWOUT JET - OFF THE FLOOR - *R2100**

MANUFACTURE DATE
AUGUST 2010
TO PRESENT

DATE ISSUED
08/31/10
DATE REVISED

DRAWING NUMBER
9908-402-001