

# Extruded Aluminum Combination Louver / Damper

## HVAC/R fact Sheet

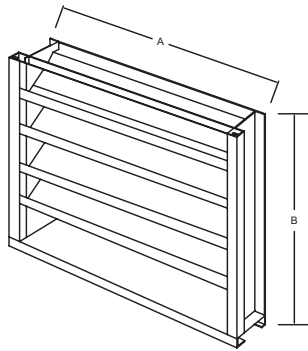

**Front View**

Note: Above "A" and "B" dimensions are undersized by 1/2" + or - normal tolerance of .0625".

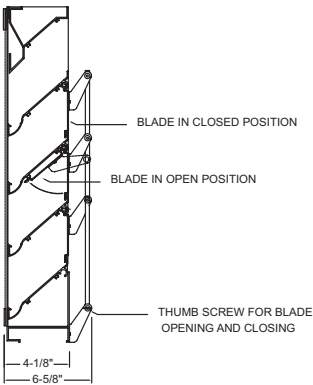

**Side View**

(w/ Std. Thumb Screw)

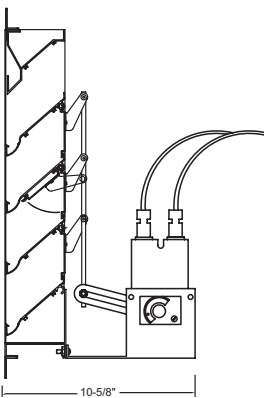

**Side View**

(w/ Optional Motor and Flanged Frame)

## Extruded Aluminum Combination Louver / Damper Models 20UA86-20UA99, 20UC01-20UC39

Heavy duty Extruded Aluminum construction designed to protect the air intake and exhaust openings in the exterior walls of any building from rain and weather while still providing efficient airflow. The drainable blade design provides the best protection against water entering the opening by channeling water away from the blades and down the jambs. This eliminates water cascading from blade to blade. The adjustable rear blades allow for tight shutoff of the opening when needed.

### Standard Construction:

#### Frame

- 4" deep channel x .080 thick Extruded Aluminum.

#### Blades

- Drainable style, .080 thick Extruded Aluminum, positioned at a 45 degree angle and spaced approximately 4" centers.

#### Seals

- Extruded TPV.

#### Linkage

- On-blade type with a Thumb Screw Operator as standard.

#### Birdscreen

- 1/2" Flattened Aluminum in a removable frame mounted on the interior.

#### Construction

- Screwed.

#### Finish

- Mill.

#### Minimum Size

- 12" W x 12" H.

#### Maximum Single Section Size

- 60" W x 96" H

#### Flange

- 1-1/2" Flange, .080 thick Extruded Aluminum.

#### Options (at additional cost)

- Up to 48" W x 48" H, 100 to 240 VAC, 50/60 Hz Motor Pack.
- Over 48" W x 48" H, 24 to 240 VAC, 50/60 Hz Motor Pack.

## Performance Data

AMCA Standard 500-L provides a method for testing and rating louvers. These tests were performed under certain sets of laboratory conditions. These performance ratings do not guarantee that other environmental conditions may actually occur. Use safety factors when selecting louver sizes based upon performance.

### Free Area Chart (Sq. ft.):

		Louver Width in Inches							
		18	24	30	36	42	<b>48</b>	54	60
Louver Height in Inches	18	0.70	0.98	1.25	1.53	1.81	2.09	2.37	2.65
	24	1.06	1.49	1.91	2.34	2.76	3.18	3.61	4.03
	30	1.36	1.91	2.45	2.99	3.54	4.08	4.63	5.17
	36	1.73	2.42	3.11	3.80	4.49	5.18	5.87	6.56
	42	2.03	2.84	3.65	4.46	5.26	6.07	6.88	7.69
	<b>48</b>	2.39	3.35	4.30	5.26	6.21	<b>7.22</b>	8.12	9.08
	54	2.69	3.76	4.84	5.92	6.99	8.07	9.14	10.22
	60	3.05	4.28	5.50	6.72	7.94	9.16	10.38	11.60
	66	3.35	4.69	6.04	7.38	8.72	10.06	11.40	12.74
	72	3.72	5.21	6.69	8.18	9.67	11.15	12.64	14.13
	78	4.02	5.62	7.23	8.84	10.44	12.05	13.66	15.27
	84	4.38	6.13	7.89	9.64	11.39	13.15	14.90	16.65
	90	4.68	6.55	8.43	10.30	12.17	14.04	15.92	17.79
96	5.05	7.06	9.08	11.10	13.12	15.14	17.16	19.17	

### PRESSURE DROP

Standard Air - .075 lbs per cubic foot  
Test size - 48" x 48" (Intake)

Ratings do not include the effect of a birdscreen

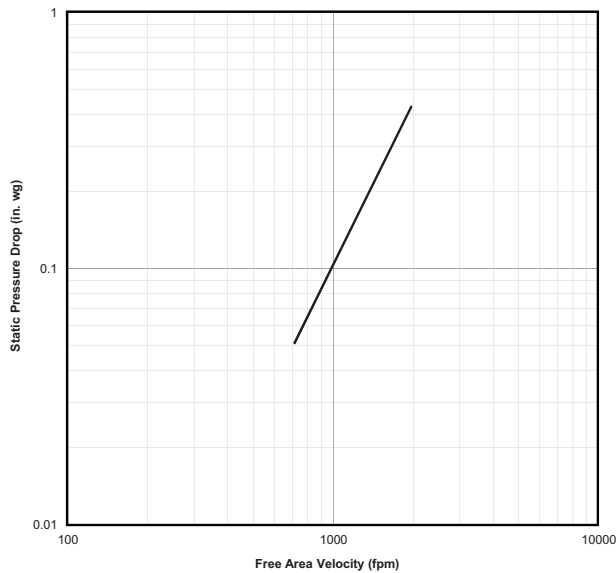

### WATER PENETRATION

Standard Air - .075 lbs per cubic foot  
Test size - 48" x 48" for a 15 minute duration

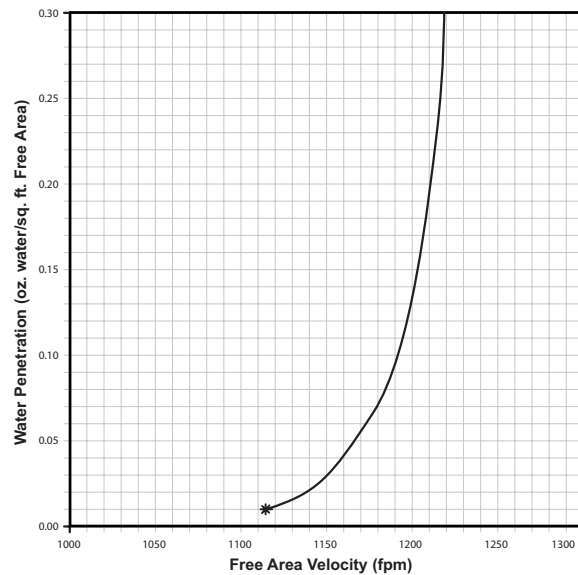

The beginning point of water penetration at .01 oz./sq. ft. is 1118 fpm free area velocity.

Call or visit your local branch or go to [grainger.com/dayton](http://grainger.com/dayton) for complete product line information



Find it at Grainger.

March 2014