

PULSAFEEDER®

Chemical solution and slurry metering pumps designed, engineered, and built to last. The pump case is molded of a rugged, chemical resistant ABS. Mounting pads and a built-in wall mounting bracket allow a choice of flat surface or wall mounted installation.

The thermal or impedance protected gear motor is safe, quiet and dependable. All metal gearing parts are heat-treated and the output shaft is supported by heavy-duty bearings.

The feeder head is molded of UV and acid resistant polycarbonate and is designed to snap on and off without tools.

A 10-minute solid-state electric current interrupter is a standard feature, built into every MEC-O-MATIC Dolphin Series pump.

Features

- Feed rates from 13 gpd (2.05 lph) to 97 gpd (15.3 lph) at 25 psi (1.72 bar).
- Pump case is molded chemical resistant ABS.
- Thermal or impedance protected gearmotor is safe, quiet and dependable.
- All metal gearing parts are heat-treated.
- Output shaft is supported by heavy duty bearings.
- Conforms to ANSI/NSF STD. 50: Equipment for swimming pools, spas, hot tubs, and other recreational water facilities.

Controls



- On/Off Switch
- 10 minute solid state electronic current interrupter

Operating Benefits

- Quick-release, twist-off, clear polycarbonate, acid-resistant head.
- Self-lubricating chemical resistant roller assembly.
- Durable, long-lasting tubing with no tube adjustment.
- Heavy duty shaded pole gearmotor with lifetime lubrication.



Aftermarket

- KOPkits
- Gauges
- Dampeners
- Pressure Relief Valves
- Tanks
- Pre-Engineered Systems
- Process Controllers (MicroVision)



Contact factory for applicable agency approvals.

MEC-O-MATIC Dolphin Series Peristaltic Metering Pumps

MEC-O-MATIC Dolphin Series

Specifications and Model Selection

MODEL		UD10	UD50	UD75
Feed Rate	GPD	13	60	97
	(max.) LPH	2.05	9.46	15.3
CC per Minute	60 Hz	34	158	255
	50 Hz	29	145	212
Rev per Minute		10	50	75
Pressure	PSIG	25		
	(max.) BAR	1.72		
Head	Tubing	.25" I.D. x .44" O.D.		
Connection	Tubing	.17" I.D. x .25" O.D.		

Engineering Data

Pump Head Materials:	Chemical Resistant Resin
Pump Head Tubing:	Synthetic Rubber
Injection Fitting	
(standard w/check vlv):	PVC
Strainer:	FPP
Tubing:	PE
Pump Housing:	Chemical Resistant Resin

Important: Material Code - PVC=Polyvinyl Chloride, PE=Polyethylene.

Power Input:	115 VAC/60 HZ
	230 VAC/50-60 HZ

Average Current Draw:

@ 115 VAC; Amps:

Model UD10	.42 Amps
Model UD50	.62 Amps
Model UD75	.72 Amps

@ 230 VAC; Amps:

Model UD10	.30 Amps @60Hz / .35 Amps @50Hz
Model UD50	.34 Amps @60Hz / .40 Amps @50Hz
Model UD75	.36 Amps @60Hz / .42 Amps @50Hz

Approvals:

Conforms to ANSI/NSF STD. 50
Equipment for swimming pools, spas, hot tubs, and other recreational water facilities.

Shipping Weight:	7 lbs
-------------------------	-------

Dimensions

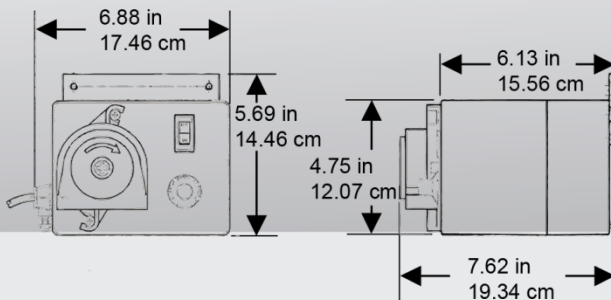

Applications

- Cooling Towers
- Swimming Pools
- Boilers
- Agriculture
- Laundries
- Livestock
- Food Processing
- Residential Water Treatment
- Car Washes
- Photo Processors
- Metal Finishing
- Warewashing

Typical Installation



PULSAFEEDER

27101 Airport Road
Punta Gorda, FL 33982
Phone: +1(941) 575-3800
Fax: +1(941) 575-4085

www.pulsatron.com



An ISO 9001 Certified Company

MOM003 D20

IBEX
FLUID & METERING