

REVISION HISTORY					
REV	BY	CHK	C.R. No.	DATE	DESCRIPTION
A	GKW	G.S.	08-012	1/10/2008	RELOCATED LOAD HOLE.

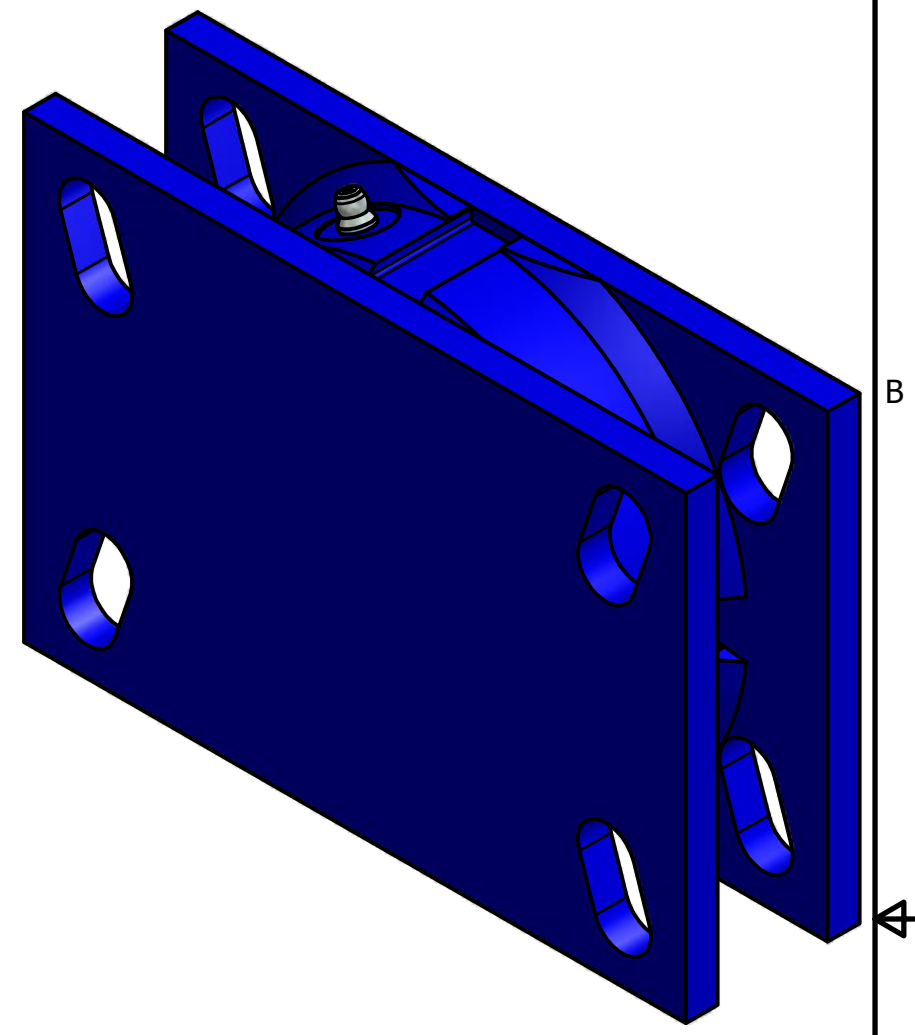
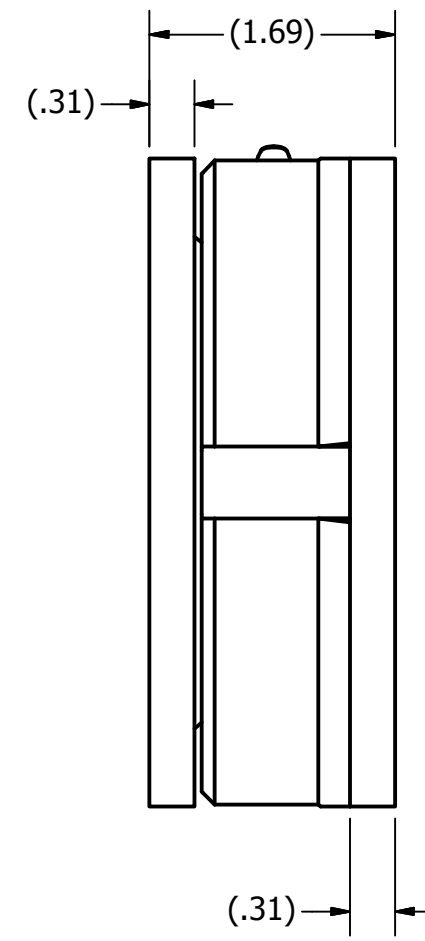
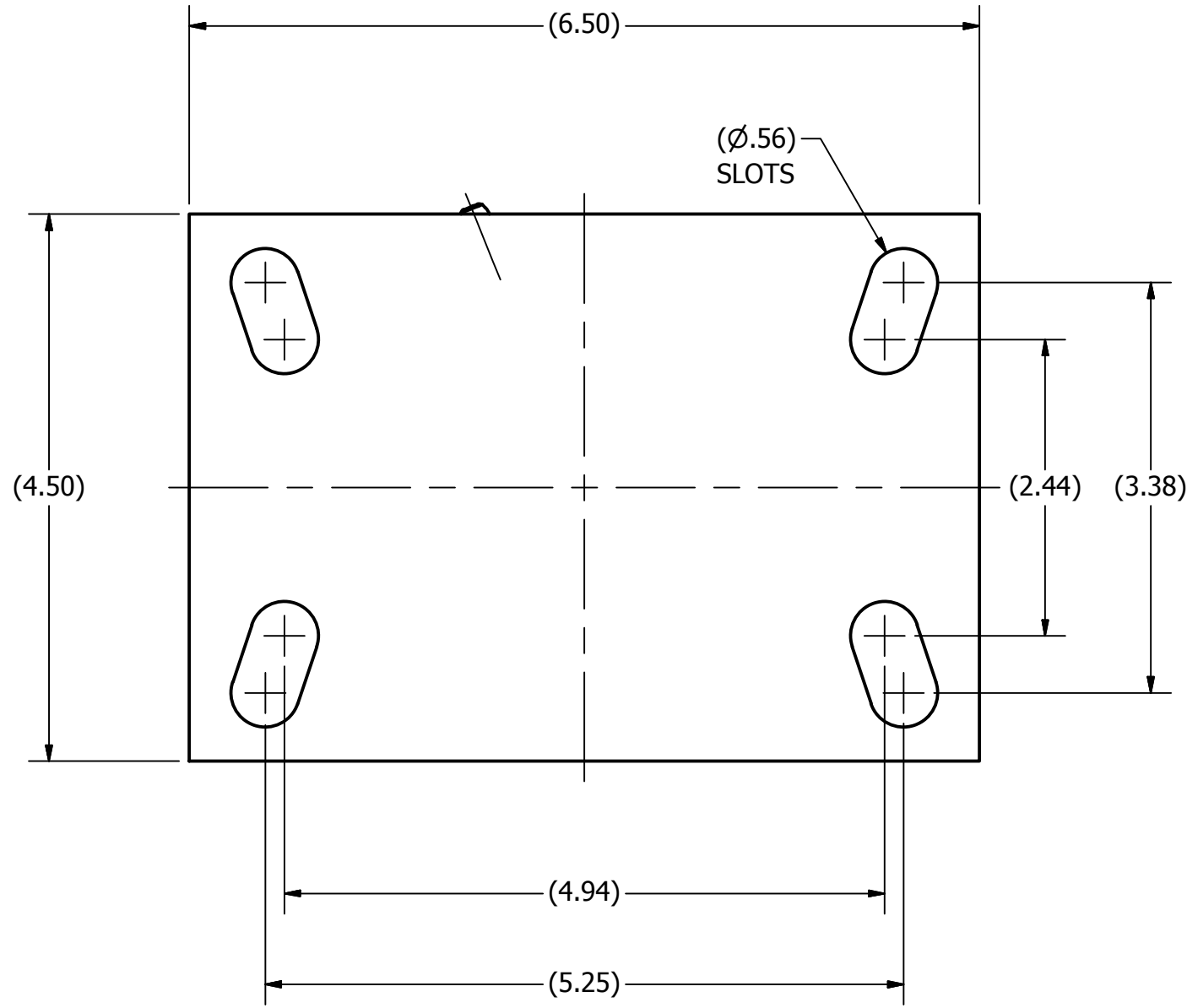

NOTE: BLUE POWDER COAT

- NOTES:**
1. BREAK SHARP EDGES AND REMOVE ALL BURRS.
  2. ALL DIMENSIONS IN ( ) ARE REFERENCE.
  3. ALL DIMENSIONS ARE IN INCHES.
  4. FINISH = 125 RMS (MIN) UNLESS OTHERWISE NOTED.

3D\675T110020			
THIS DRAWING CONTAINS INFORMATION DEEMED PROPRIETARY TO RWM CASTERS CO., AND IS TO BE USED ONLY FOR THE PURPOSE FOR WHICH IT IS SUBMITTED, AND FURTHER SHALL NOT BE COPIED IN WHOLE OR IN PART WITHOUT WRITTEN PERMISSION FIRST OBTAINED FROM RWM CASTERS COMPANY. © R.W.M. 2008			
DRAWN BY:	W.H.	7/13/1993	<b>RWM CASTERS</b> 1225 Isley Road, P.O. Box 668, Gastonia, NC 28053 Phone: 1-800-634-7704, Fax: 1-800-253-6634
CHECKED BY:	R.S.	7/13/1993	
MATL.:			
WEIGHT			T75-75RT TURNTABLE ASSEMBLY
UNLESS OTHERWISE SPECIFIED		SIZE B	DWG NO
0.XXX±0.005 0.XX±0.03 ANG.±1°			<b>675T110020</b>