



Ranger® Count 3000

Counting Scales



The Best Compact Counting Scale in its Class!

The multipurpose Ranger Count 3000 has all of the capabilities to produce precise results rapidly for a variety of applications. With weighing, parts counting, check counting, and accumulation functions, Ranger Count 3000 is the ideal scale to meet many industrial counting needs. Portable and equipped with a rechargeable battery, this scale is beneficial in every corner of the factory and is equipped with functions and features that elevate the Ranger Count 3000 to a class of its own.

Standard Features Include:

- **Precise Counting and Weighing Performance with 30 Item Library**—Accurate weighing and counting performance is assured through Ranger Count 3000's high resolution, 30 item library data storage function and auto-optimization software that reduces errors and ensures accuracy.
- **The Most User Friendly Counting Scale on the Market**—The three backlit LCD displays, including a centrally located count display, along with an easy-to-navigate menu, make Ranger Count 3000 extremely simple to use and increase the proficiency of weighing and counting operations.
- **Rapid Stabilization Provides Unmatched Throughput**—View your results in just one second, and then see your efficiency, throughput and productivity soar!

Ranger® Count 3000 Counting Scales

Precise Counting and Weighing with 30 Item Library

The high resolution Ranger Count 3000 has a 1:30,000 display resolution and 1:1,500,000 internal counting resolution. It also features advanced auto-optimization software which recalculates the average piece weight as the overall weight increases, ensuring accuracy and minimizing counting errors. The Ranger Count 3000 also offers a 30 item library data storage function that can store 12-digit part numbers, average piece weights, checkcounting or checkweighing parameters, tare weights and accumulated weights or counts for quick and simple retrieval of frequently used data.



The Most User Friendly Counting Scale on the Market

The inviting display and navigation make Ranger Count 3000 extremely simple to use. The three-window backlit LCD display includes a centrally-located count display and weight and piece weight displays. Eight function keys, including dedicated SAMPLE and TARE keys, and full numeric keypad make setup and input operations simple and straightforward.



Rapid Stabilization

Ranger Count 3000 produces accurate results within one second. The rapid stabilization virtually eliminates your wait time and allows you to move at a pace determined by you and not your weighing equipment. Work with confidence that your results are accurate and will be displayed efficiently. Maximize your throughput without sacrificing accuracy with the Ranger Count 3000.

More Connectivity Options than any other Compact Counting Scale

Ranger Count 3000 offers the highest level of connectivity in its class through its Standard RS232 with optional Ethernet, second RS232, or USB that offers connection to multiple peripherals. Ranger Count 3000 can also support two-scale counting through the Optional 2nd Platform to support weighing jobs that require a higher capacity platform or additional pan space. Whether your data transfer requirements are simple or complex, Ranger Count 3000 offers the necessary functionality to meet your needs.



Portability and Versatile Power Options

Say goodbye to being restricted to working only near power outlets! With its convenient carrying handle and rechargeable lead acid battery that can provide power for more than 210 hours, Ranger Count 3000 can provide many hours of uninterrupted operation in the area of your workspace that most conveniently fits your needs. It can also be powered through the easy connect power cord that takes up minimal space and automatically adapts to different power line voltages and frequencies, eliminating disruptions in workflow due to power outages and shortages.



Approvals

The Ranger 3000 has been designed to meet or exceed the Class III accuracy requirements in accordance with the National Institute of Standards and Technology (NIST) Handbook 44.



Application Modes

- **Weighing**—Determine the weight of items in the selected unit of measure.
- **Parts Counting**—Count samples of uniform weight.
- **Check Counting/Weighing**—Compare the Count/Weight of a sample against target limits.
- **Accumulation**—Totalization of weight and count. Calculates total accumulated weight and count of separate items

Outline Dimensions

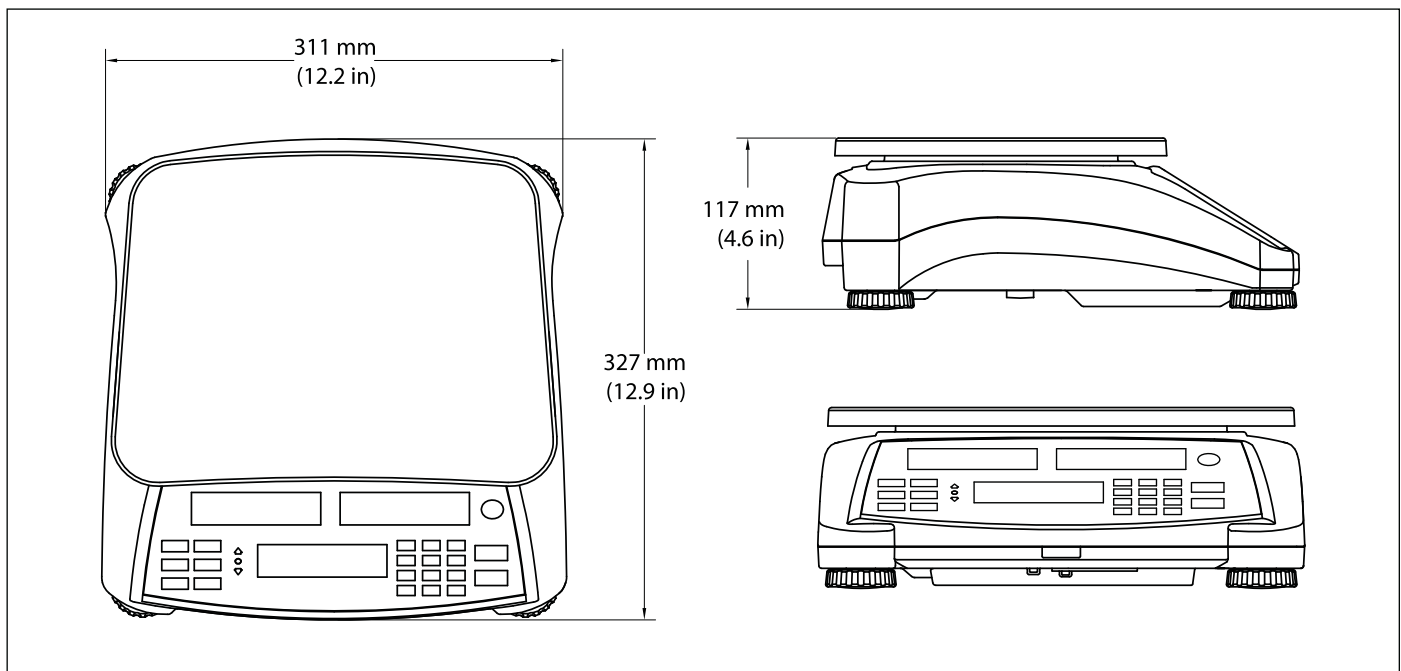

Ranger® Count 3000 Counting Scales

Model	RC31P1502	RC31P3	RC31P6	RC31P15	RC31P30
Default Capacity × Readability	1.5 kg × 0.00005 kg 3 lb × 0.0001 lb 1500 g × 0.05 g 48 oz × 0.002oz	3 kg × 0.0001 kg 6 lb × 0.0002 lb 3000 g × 0.1 g 96 oz × 0.005oz	6 kg × 0.0002 kg 15 lb × 0.0005 lb 6000 g × 0.2 g 240 oz × 0.01oz	15 kg × 0.0005 kg 30 lb × 0.001 lb 15000 g × 0.5 g 480 oz × 0.02oz	30 kg × 0.001 kg 60 lb × 0.002 lb 30000 g × 1 g 960 oz × 0.05oz
Certified Capacity × Readability	1.5 kg × 0.0005 kg 3 lb × 0.001 lb 1500 g × 0.5 g 48 oz × 0.02oz	3 kg × 0.001 kg 6 lb × 0.002 lb 3000 g × 1 g 96 oz × 0.05oz	6 kg × 0.002 kg 15 lb × 0.005 lb 6000 g × 2 g 240 oz × 0.1oz	15 kg × 0.005 kg 30 lb × 0.01 lb 15000 g × 5 g 480 oz × 0.2oz	30 kg × 0.01 kg 60 lb × 0.02 lb 30000 g × 10 g 960 oz × 0.5oz
Min. Recommended Sample Weight	0.002 lb / 1 g	0.004 lb / 2 g	0.01 lb / 4 g	0.02 lb / 10 g	0.04 lb / 20 g
Min. Recommended APW	0.00001 lb / 0.005 g	0.00002 lb / 0.01 g	0.00005 lb / 0.02 g	0.0001 lb / 0.05 g	0.0002 lb / 0.1 g
Max. Internal Counting Resolution	1:1,500,000				
Max. Displayed Resolution	1:30000	1:30000	1:30000	1:30000	1:30000
Construction	ABS housing, stainless steel platform				
Weighing Units	kg, g, lb, oz, lb:oz				
Application Modes	Weighing, Parts Counting, Checkweighing, Checkcounting, Accumulation				
Display	3-Window, 1 inch / 26 mm high LCD display with white backlight, 6-digit, 7-segment				
Checkweighing Indicators	3 LED (yellow, green, red) with configurable operation and alert beeper				
Memory	30 item library				
Keypad	8 function, 12 numeric mechanical keys				
Zero Range	4% or 20% of full scale capacity				
Tare Range	Full capacity by subtraction				
Stabilization Time	1 second				
Auto-Zero Tracking	Off, 0.5, 1 or 3 divisions				
Safe Overload Capacity	150% of capacity				
Power	100-240 VAC / 50-60 Hz internal universal power supply, internal rechargeable lead acid battery				
Battery Life	210 hours continuous use with 12 hour recharge time				
Calibration	External, with user-selectable calibration weight				
Interface	Built-in RS232, optional 2 nd platform, 2 nd RS232, USB, Ethernet				
Operating Temperature Range	14° F to 104° F / -10° C to 40° C				
Pan Size (W × L)	11.8 × 8.9 in / 300 × 225 mm				
Scale Dimensions (W × L × H)	12.2 × 12.9 × 4.6 in / 311 × 327 × 117 mm				
Shipping Dimensions (W × L × H)	15.6 × 17.6 × 7.7 in / 397 × 447 × 195 mm				
Net Weight	9.2 lb / 4.2 kg				
Shipping Weight	12 lb / 5.45 kg				

Other Standard Features and Equipment

ABS housing, stainless steel platform, 30 item library (stores 12-digit part numbers, average piece weights, checkcounting or checkweighing parameters, tare weights and accumulated weights or counts), 210 hours of battery life, 3 LED (yellow, green, red) checkweighing lights with selectable operation and audible signal settings, auto tare, APW Auto-Optimization, transportation handle, numeric keypad, sealed front panel, menu lockswitch, up front level indicator, adjustable leveling feet, selectable environmental and auto-print settings, stability indicator, overload and underload indicators, low battery indicator, auto shut-off, auto tare

Approvals

- **Metrology:** US NTEP 3000e
- **Product Safety:** CAN/CSA-C22.2 No. 61010-1-04; UL Std. No. 61010-1 (2nd Edition)
- **Electromagnetic Compatibility:** FCC, Part 15, Class A; EN61326-1:2006 (Class B); C-Tick
- **Other:** WEEE/ROHS

Accessories

Second Scale, Kit 30037446
Ethernet Kit 30037447
Second RS232 Kit 30037448
USB Kit 30037449

Weigh Below Hook 30037450
In Use Cover 30037451
SF40A Impact Printer Contact Ohaus

OHAUS CORPORATION

* 7 Campus Drive
 Suite 310
 Parsippany, NJ 07054 USA

Tel: 800.672.7722
 973.377.9000
 Fax: 973.944.7177

www.ohaus.com

With offices throughout
 Europe, Asia, and
 Latin America

*ISO 9001:2008
 Registered Quality
 Management System

