

Please read and save these instructions. Read carefully before attempting to assemble, install, operate or maintain the product described. Protect yourself and others by observing all safety information. Failure to comply with instructions could result in personal injury and/or property damage! Retain instructions for future reference.

Westward® Hydraulic Service Jacks

Description

Westward hydraulic service jacks are used for lifting part of a total vehicle (i.e., one wheel). These jacks are equipped with a built-in by-pass device to prevent damage to jack from overpumping. An internal safety valve prevents damage to jack from overloading. Applications include automotive, truck, farm, industrial and construction. Air models feature a powerful air motor, for effortless lifts of rated loads, conventional foot pumping and handle pumping. These jacks are designed to meet applicable ANSI/ PALD Standards. RECOMMENDED AIR SUPPLY: 110-175 PSI at 7.8 CFM.

Specifications

Model	Capacity	Length	Min. Height	Max. Height
1ZKX4	4 Ton	47- ⁷ / ₈ "	5"	24"
5M455A (air model)	4 Ton	50- ⁵ / ₈ "	5"	24"
1ZKX6	5 Ton	55- ⁵ / ₈ "	7"	27"
5M456A (air model)	5 Ton	55- ⁵ / ₈ "	7"	27"
1ZKX5	10 Ton	55"	7- ¹ / ₈ "	27- ¹ / ₈ "
1ZKX9 (air model)	10 Ton	55"	7- ¹ / ₈ "	27- ¹ / ₈ "

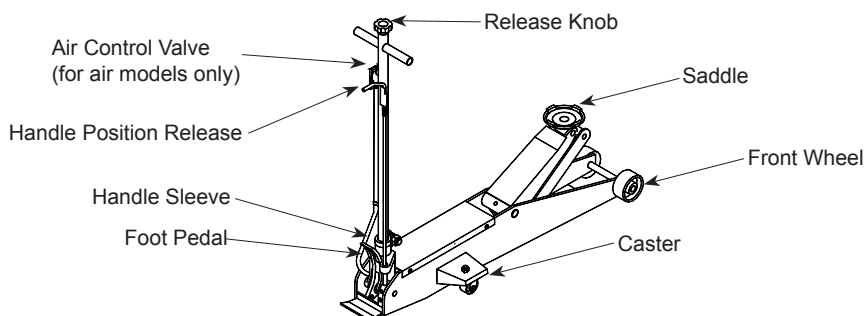

Figure 1 — Hydraulic Service Jack Components

General Safety Information

WARNING Study, understand, and follow all instructions before operating this device. Lifting device only. Intended use is for lifting part of a total vehicle, only one wheel or axle at a time. Immediately after lifting, support vehicle with appropriate means. Do not exceed rated capacity. Use only on hard, level surfaces capable of sustaining rated capacity loads. Lift only on those areas of the vehicle as specified by the vehicle manufacturer. Ensure that the lift point is properly centered on the jack saddle. Always wear safety glasses when using this equipment. Inspect jack before each use. Do not use if bent, broken, leaking, or damaged components

are noted. No alteration of this product is allowed. Do not use this device for any purpose other than that for which it was intended. Failure to heed any one or combination of these warnings may result in severe personal injury and/or property damage.

Before Use

1. Secure handle into handle sleeve with bolt provided. Tighten securely to prevent accidental removal of handle while in use.
2. Ensure that release mechanism is properly connected by turning the release knob clockwise and counter-clockwise.

3. With saddle fully lowered, remove oil filler plug/screw to allow any trapped air to escape. Ensure that oil level is within ³/₈" from filler hole. Reinstall oil filler plug/screw.
4. On air models, pour a teaspoon of air tool lubricant into air supply inlet of air control valve. Connect to air supply and operate for 3 seconds to evenly distribute lubricant.
5. Squirt a small amount of hydraulic jack oil on pistons and thoroughly lubricate all moving parts of jack.

Operation

WARNING Off-centered loads and loads lifted while jack is not level may damage the jack or cause personal injury.

LIFTING

1. To prevent inadvertent vehicle movement, fully engage emergency brake, put transmission gear in park.
2. Close release valve by turning the release knob clockwise firmly. Center jack saddle under lift point suggested by vehicle manufacturer.
3. Pump the handle or foot pedal until saddle contacts lift point. Ensure that load is centered on saddle.
4. To lift, pump handle or squeeze air control valve (air model) until load reaches desired height.

NOTE: Never use foot pedal to raise load. The jack is equipped with a handle position lock. To release, pull lever up, then back until lever is locked into place. This will allow full range of handle movement.

WARNING This is a lifting device only. The load must be supported immediately by a pair of appropriately rated jack stands.

Westward® Hydraulic Service Jacks

Operation (Cont.)

LOWERING

Keep hands, feet, and clutter clear of ground area before lowering the load.

Raise load high enough to clear vehicle stands, then SLOWLY open the release valve by turning handle knob counterclockwise.

IMPORTANT: Avoid shock loads created by quickly opening and closing the release valve as the load is being lowered. Shock loads can create dangerously high operating pressures within the hydraulic system, causing system failure and resulting in personal injury and/or property damage.

Maintenance

IMPORTANT: Use only a good grade hydraulic jack oil such as Mobil DTE 13M or equivalent. Avoid mixing types of oil. Do not use hydraulic brake fluid, alcohol, glycerine, detergent motor oil, or dirty oil. Improper fluid can cause serious

internal damage to the jack rendering it inoperative.

ADDING OIL

1. Position the jack on level ground and fully lower the saddle. Remove oil filler plug/screw.
2. Fill oil to within 3/8" of filler hole. **DO NOT OVERFILL!** If overfilled, the jack will not lower to published minimum height. If underfilled, the jack will not reach published maximum height. Adjust fluid level as needed. Always reinstall oil filler plug/screw before use.

CHANGING OIL

1. Remove oil filler plug/screw.
2. Turn jack over and drain old oil out through oil filler hole.

NOTE: Dispose of hydraulic oil in accordance with local regulations.

3. Refill with new oil until within 3/8" of filler hole.

IMPORTANT: Do not allow dirt or other foreign material to enter the hydraulic system when filling.

4. After refilling, remove air from system by opening release valve and rapidly pumping handle several times. Reinstall oil filler plug/screw when done.

LUBRICATION

1. Add lubricating oil to all moving parts as needed.
2. Apply grease to greasing nipple periodically.
3. On air models 1ZKX9, 5M455A and 5M456A, pour air tool lubricant into the air supply inlet at air control valve periodically.

PREVENTING RUST

1. Check ram and piston periodically for signs of corrosion. Clean as needed with an oily cloth.
2. When not in use, store jack with saddle and piston fully retracted.

Troubleshooting Chart

Symptom	Possible Cause(s)	Corrective Action
Jack will not lift load	<ol style="list-style-type: none"> 1. Release valve not tightly closed 2. Overload condition 3. Pressure of air supply is too low (for air models) 	<ol style="list-style-type: none"> 1. Ensure release valve tightly closed 2. Remedy overload condition 3. Change to a suitable air source
Jack will lift but not maintaining pressure	<ol style="list-style-type: none"> 1. Same as above 2. Hydraulic unit malfunctioning 	<ol style="list-style-type: none"> 1. Same as above 2. Replace
Jack will not lower after unloading	<ol style="list-style-type: none"> 1. Reservoir overfilled 2. Linkages binding 	<ol style="list-style-type: none"> 1. Drain fluid to proper level 2. Clean and lubricate moving parts
Poor lift performance	<ol style="list-style-type: none"> 1. Fluid level low 2. Air trapped in system 	<ol style="list-style-type: none"> 1. Ensure proper fluid level 2. With ram fully retracted, remove oil filler plug to let pressurized air escape, reinstall oil filler plug
Will not lift to full height	Fluid level low	Ensure proper fluid level

For Repair Parts, call 1-800-323-0620

24 hours a day - 365 days a year

Please provide following information:

- Model number
- Serial number (if any)
- Part description and number as shown in parts list

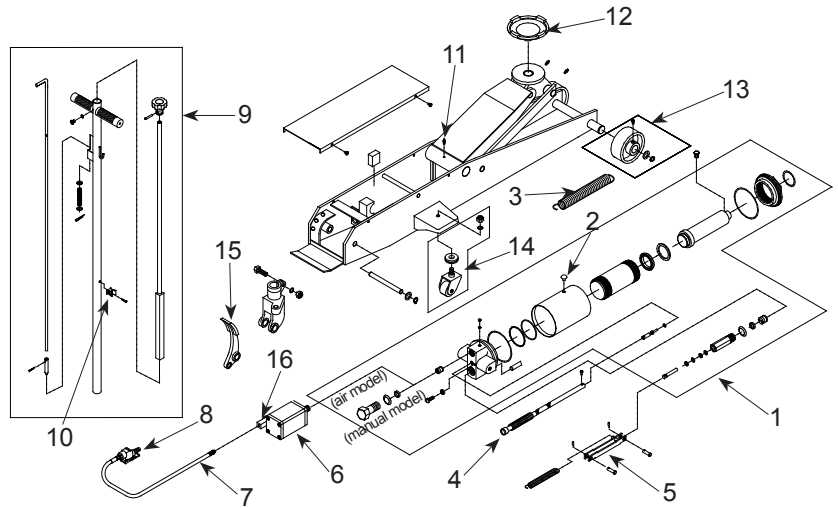

Figure 2 — Repair Parts Illustration for Models 1ZKX4, 1ZKX6, 5M455A, 5M456A (5 Ton model shown)

Repair Parts List

Reference Number	Description	1ZKX4 (4 Ton)	Part Number For Models:			Quantity
			5M455A (4 Ton)	1ZKX6 (5 Ton)	5M456A (5 Ton)	
1	* Power Unit	G423-20000-000	G423-60000-000	G250-70000-000	G250-20000-000	1
2	Oil Filler Plug	5905-00100-200	5905-00100-200	5905-00100-200	5905-00100-200	1
3	Return Spring	G423-00011-000	G423-00011-000	G251-00003-000	G251-00003-000	2
4	Universal Joint	G423-30000-000	G423-70000-000	G250-30000-000	G250-30000-000	1
5	Piston Link	G423-40000-000	G423-40000-000	G250-50000-000	G250-50000-000	2
6	* Air Motor	N/A	G240-01000-000	N/A	A27060-0003	1
7	Air Hose Assembly	N/A	A190-01000-000	N/A	A20060-0015	1
8	Air Control Valve	N/A	A20060-0007	N/A	A20060-0007	1
9	Handle Set	G251-40000-000	G100-90009-K01	G250-40000-000	G250-40000-000	1
10	Hose Clip	N/A	A070-40009-000	N/A	A070-40009-000	1
11	Greasing Nipple	5701-00006-000	5701-00006-000	5701-00006-000	5701-00006-000	1
12	Saddle	G423-00013-000	G423-00013-000	G251-00002-000	G251-00002-000	1
13	Front Wheel Assy.	G423-90004-K01	G423-90004-K01	G250-90004-K01	G250-90004-K01	2
14	Rear Caster Assy.	G250-90004-K02	G250-90004-K02	G250-90004-K02	G250-90004-K02	2
15	Foot Pedal	G251-00009-000	G251-00009-000	G251-00009-000	G251-00009-000	1
16	Swivel Manifold	N/A	A27060-0001	N/A	G27060-0001	1

(*) No repair parts available for power unit. and air motor

LIMITED WARRANTY

WESTWARD ONE-YEAR LIMITED WARRANTY. Hydraulic Service Jacks, Models covered in this manual, are warranted by Westward to the original user against defects in workmanship or materials under normal use for one year after date of purchase. For limited warranty claim procedures, see PROMPT DISPOSITION below. This limited warranty gives purchasers specific legal rights which vary from jurisdiction to jurisdiction.

LIMITATION OF LIABILITY. To the extent allowable under applicable law, Westward's liability for consequential and incidental damages is expressly disclaimed. Westward's liability in all events is limited to and shall not exceed the purchase price paid.

WARRANTY DISCLAIMER. Westward has made a diligent effort to provide product information and illustrate the products in this literature accurately; however, such information and illustrations are for the sole purpose of identification, and do not express or imply a warranty that the products are MERCHANTABLE, or FIT FOR A PARTICULAR PURPOSE, or that the products will necessarily conform to the illustrations or descriptions.

Except as provided below, no warranty or affirmation of fact, expressed or implied, other than as stated in the "LIMITED WARRANTY" above is made or authorized by Westward.

PRODUCT SUITABILITY. Many jurisdictions have codes and regulations governing sales, construction, installation, and/or use of products for certain purposes, which may vary from those in neighboring areas. While Westward attempts to assure that its products comply with such codes, it cannot guarantee compliance, and cannot be responsible for how the product is installed or used. Before purchase and use of a product, review the product applications, and all applicable national and local codes and regulations, and be sure that the product, installation, and use will comply with them.

Certain aspects of disclaimers are not applicable to consumer products; e.g., (a) some jurisdictions do not allow the exclusion or limitation of incidental or consequential damages, so the above limitation or exclusion may not apply to you; (b) also, some jurisdictions do not allow a limitation on how long an implied warranty lasts, consequentially the above limitation may not apply to you; and (c) by law, during the period of this Limited Warranty, any implied warranties of implied merchantability or fitness for a particular purpose applicable to consumer products purchased by consumers, may not be excluded or otherwise disclaimed.

PROMPT DISPOSITION. Westward will make a good faith effort for prompt correction or other adjustment with respect to any product which proves to be defective within limited warranty. For any product believed to be defective within limited warranty, first write or call dealer from whom the product was purchased. Dealer will give additional directions. If unable to resolve satisfactorily, write to Westward at address below, giving dealer's name, address, date, and number of dealer's invoice, and describing the nature of the defect. Title and risk of loss pass to buyer on delivery to common carrier. If product was damaged in transit to you, file claim with carrier.

Manufactured for Grainger International, 100 Grainger Pkwy., Lake Forest, Illinois 60045 U.S.A.

Manufactured for Grainger International, Inc.
100 Grainger Pkwy., Lake Forest, IL 60045 U.S.A.



For Repair Parts, call 1-800-323-0620

24 hours a day - 365 days a year

Please provide following information:

- Model number
- Serial number (if any)
- Part description and number as shown in parts list

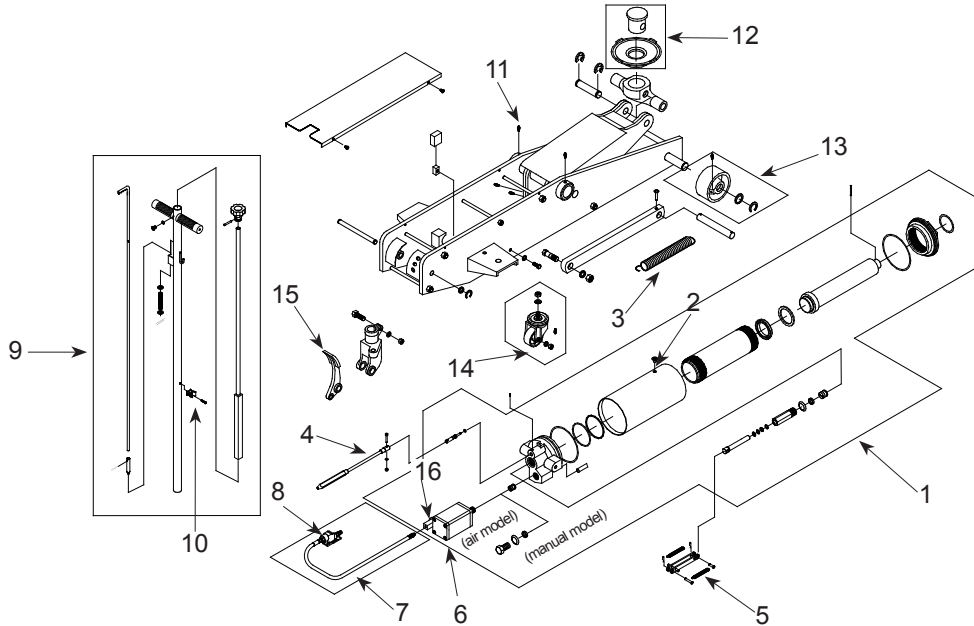

Repair Parts List

Reference Number	Description	Part Number For Models:		Quantity
		1ZKX5 (10 Ton)	1ZKX9 (10 Ton)	
1	* Power Unit	G100-80000-000	G100-40000-000	1
2	Oil Filler Screw	G62S-03301-000	G62S-03301-000	1
3	Return Spring	G100-00014-000	G100-00014-000	2
4	Universal Joint	G100-90009-K04	G100-90009-K04	1
5	Piston Link	G100-70000-000	G100-70000-000	2
6	* Air Motor	N/A	A27060-0003	1
7	Air Hose Assembly	N/A	A20060-0015	1
8	Air Control Valve	N/A	A20060-0007	1
9	Handle Set	G100-90009-K01	G100-90009-K01	1
10	Hose Clip	N/A	A070-40009-000	1
11	Greasing Nipple	5701-00001-000	5701-00001-000	8
12	Saddle Assembly	G100-90009-K02	G100-90009-K02	1
13	Front Wheel Assembly	G100-90004-K02	G100-90004-K02	2
14	Rear Caster Assembly	G661-70000-000	G661-70000-000	2
15	Foot Pedal	G251-00009-000	G251-00009-000	1
16	Swivel Manifold	N/A	A27060-0001	1

(* No repair parts available for power unit and air motor