

REV	DESCRIPTION	ECN #	CHG BY	DATE	APP'D
A	CONVERTED TO 3D		NAS	06/24/19	NAD

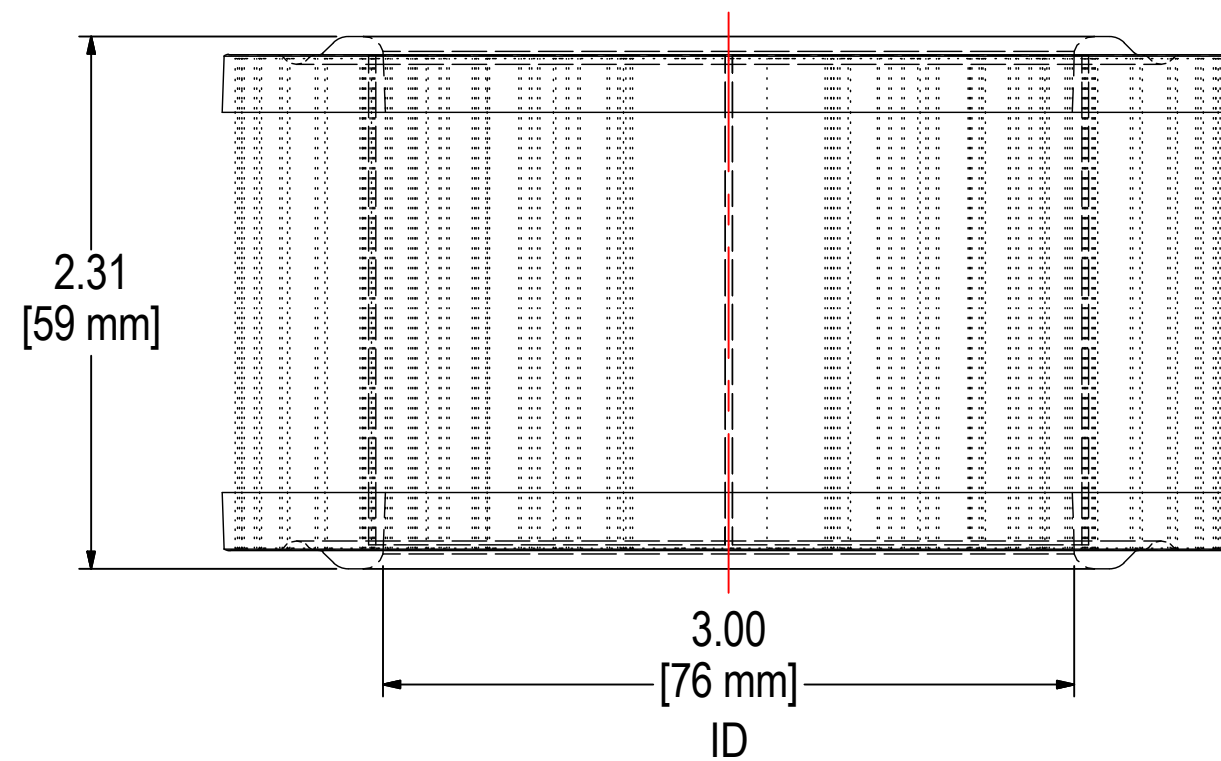
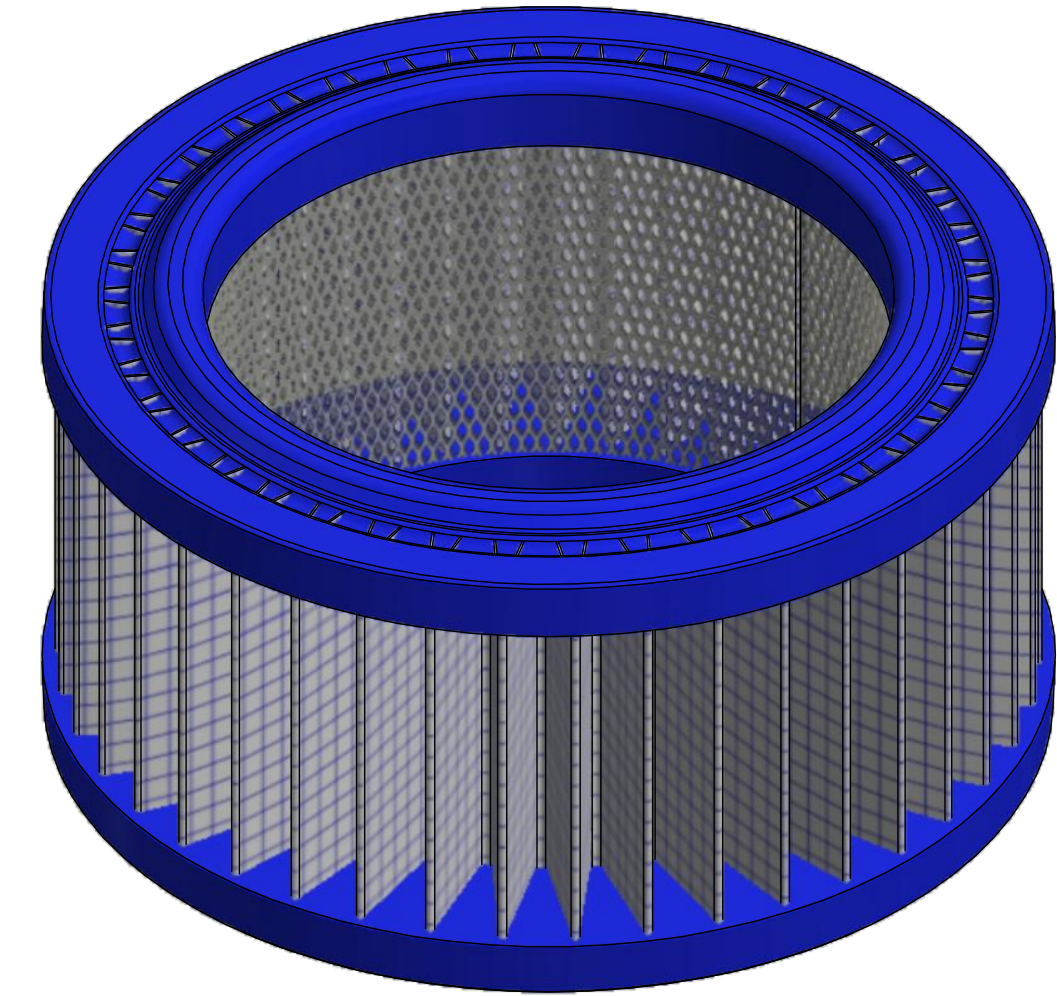
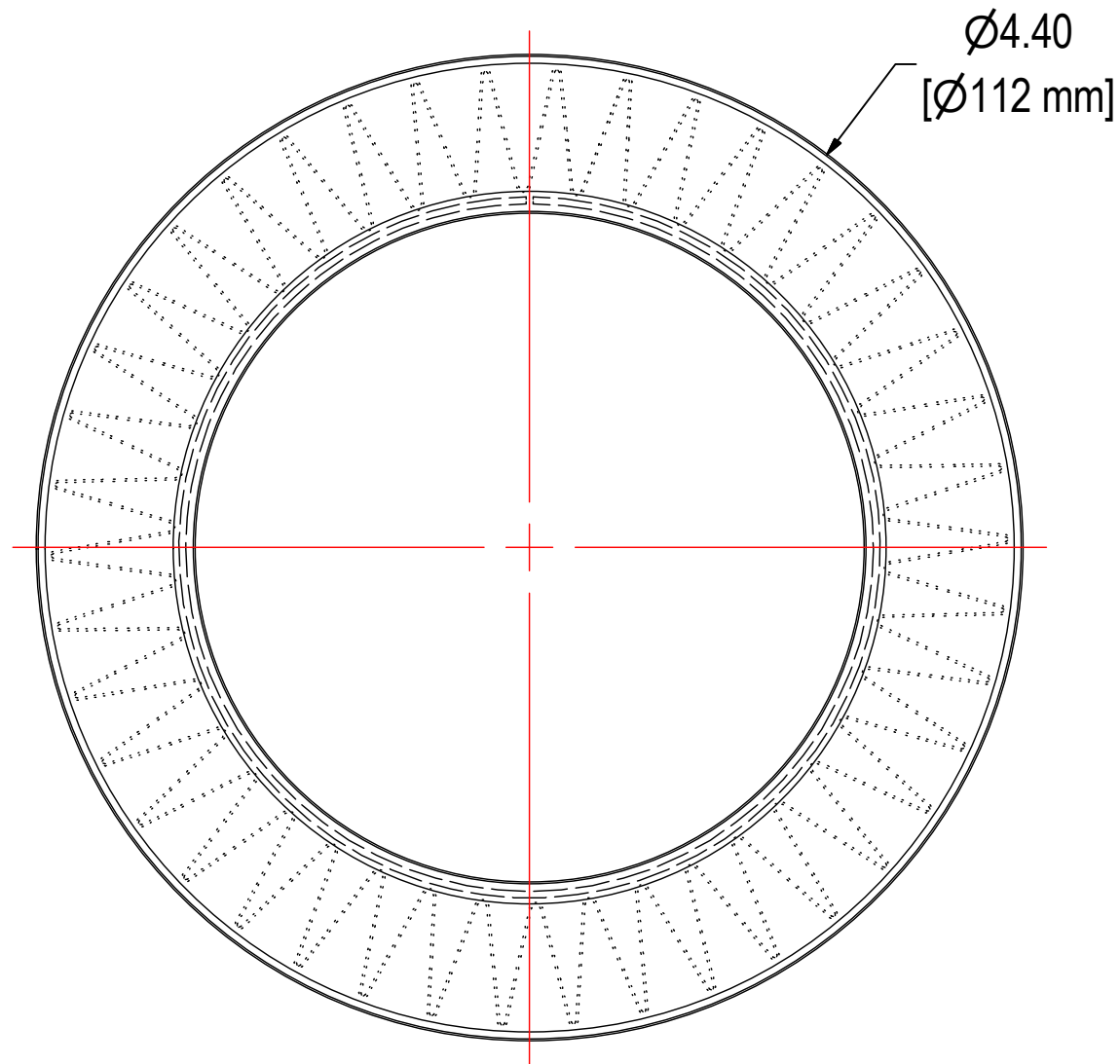

ELEMENT SPECS	
PART NUMBER	15
MATERIAL	Polyester
FLOW RATE	35 CFM 59 m ³ /hr
SURFACE AREA	0.5 ft ² 0.1 m ²
I.D.	SEE DRAWING
O.D.	SEE DRAWING
HEIGHT	SEE DRAWING