

Explosion-Proof Vibrating Horns (31X / 41X)

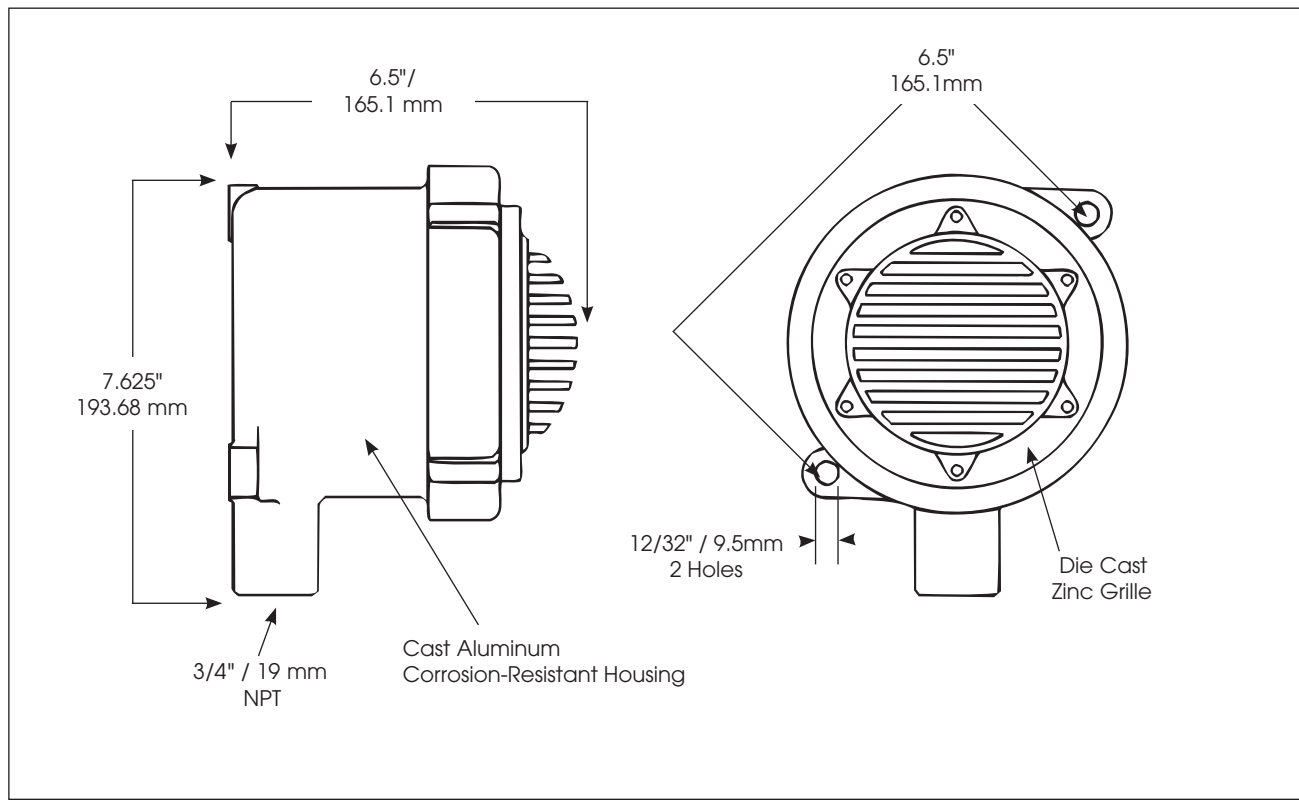

SPECIFICATIONS

Operating Temperature:	-13°F to 104°F	-25°C to 40°C
Net Weight:		
31X	7.5 lbs	3.4 kg
41X	9.0 lbs	4.1 kg
Shipping Weight:		
31X	8.1 lbs	3.7 kg
41X	10.3 lbs	4.7 kg
Height:	7.625"	193.68 mm
Depth:	6.5"	165.1 mm
Diameter:	6.5"	165.1 mm

HOW TO ORDER

31X - 120 - 3

TYPE 31X **VOLTAGE 120 (120VAC)**

31X - 240

TYPE 31X **VOLTAGE 240 (240VAC)**

REPLACEMENT PARTS

Description	Part Number
Cover Grille, Gray	KH6962J-01
Coil 31X, 120VAC	KFC1516C
Coil 31X, 240VAC	KFC1506C

41X - 024 - 1

TYPE 41X **VOLTAGE 024 (24VDC)**