

PARTS LIST			
ITEM	QTY	PART NUMBER	DESCRIPTION
1	1	150(200)D	DECAL (N/S)
2	2	150(200)K	1 1/2" & 2" CAM ARM
3	1	200G	2" Coupling Gasket
4	2	200P	CAM ARM PIN
5	1	200XCAP	2" MOLDED CAP

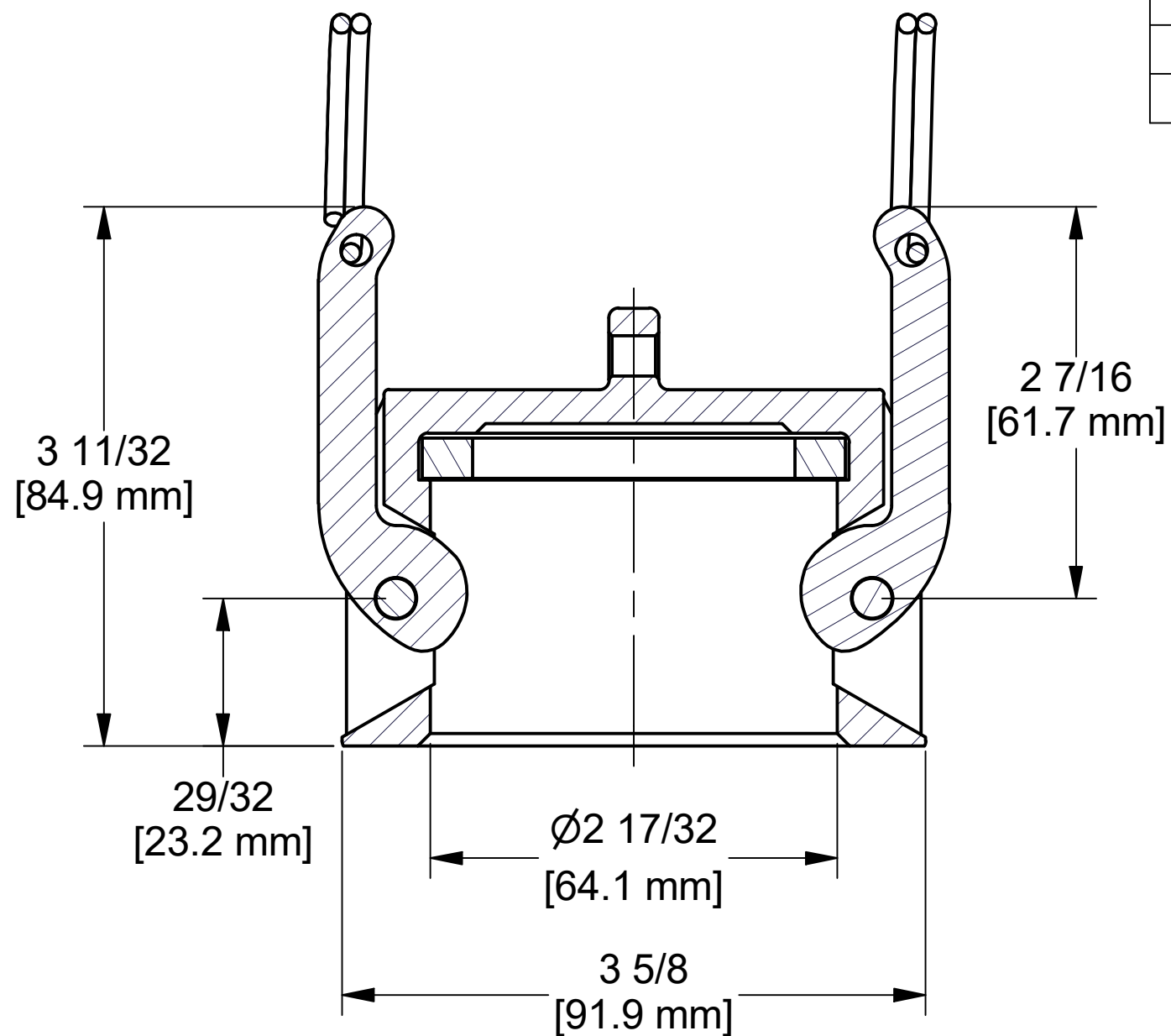

SECTION D-D
SCALE 1 : 1

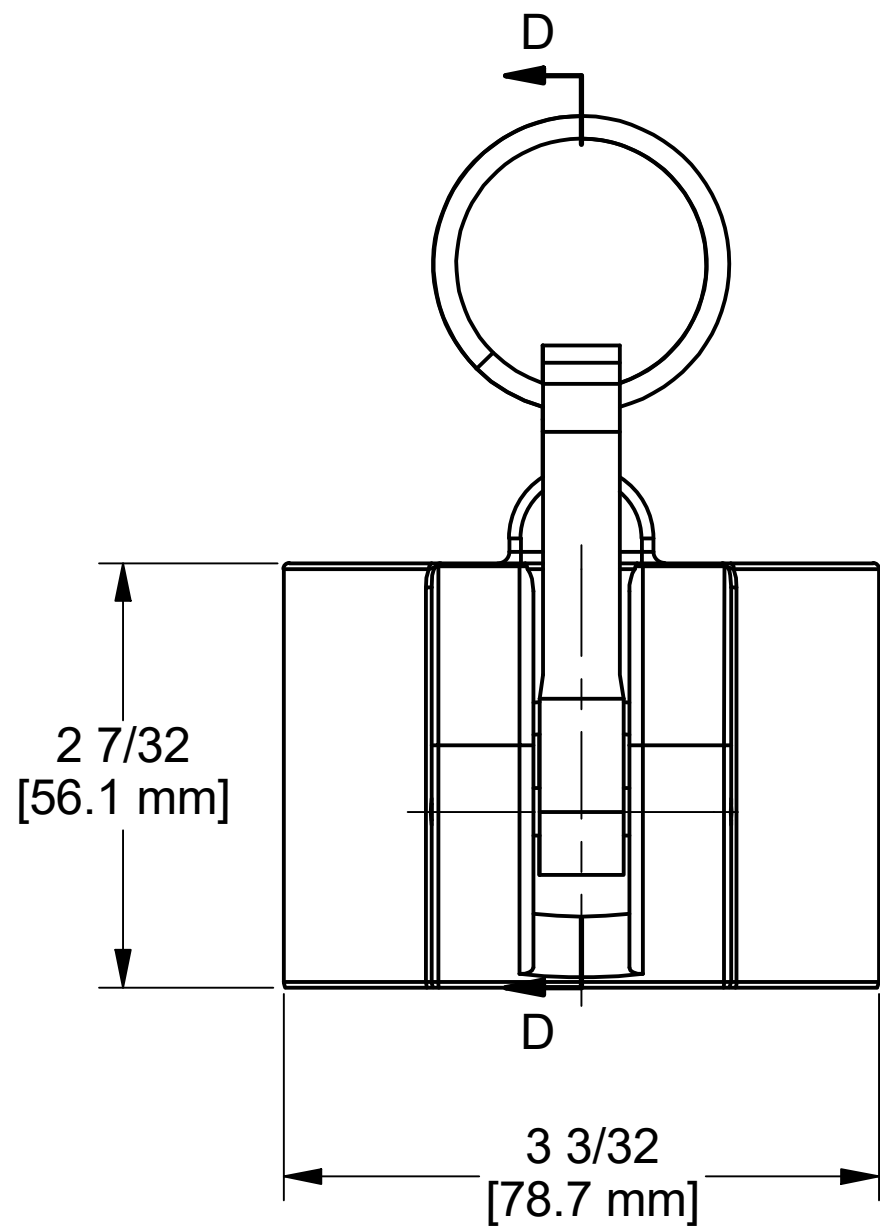
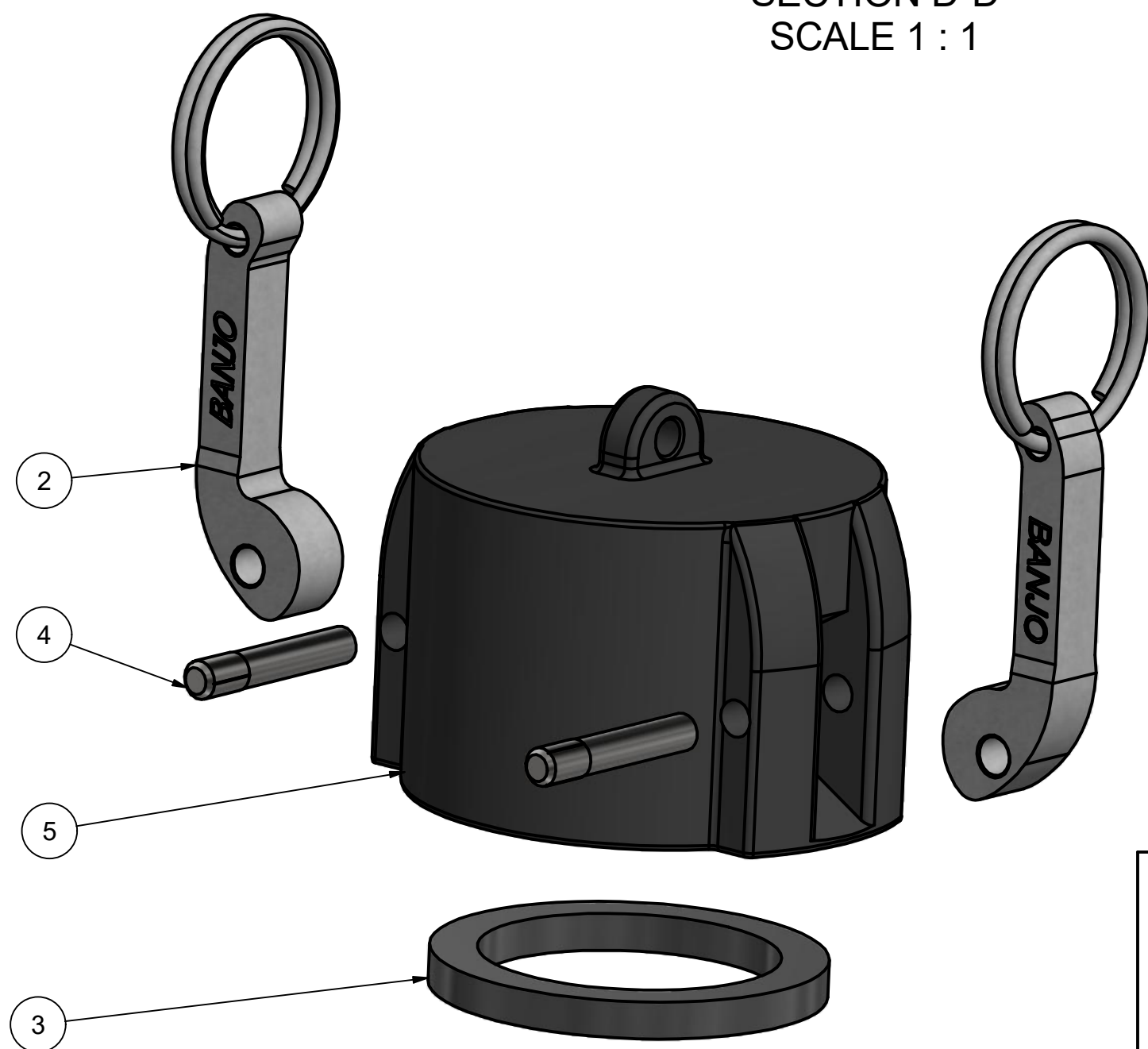

NOTE:
OPEN ARM DISTANCE: 7 21/32"



THIS DRAWING AND ALL INFORMATION CONTAINED THEREON ARE THE EXCLUSIVE PROPERTY OF BANJO CORPORATION.

UNLESS SPECIFICALLY NOTED, THIS DRAWING AND ITEMS SHOWN ON THIS DRAWING ARE SUBJECT TO CHANGE AT ANY TIME.

BANJO CORPORATION 150 BANJO DRIVE, CRAWFORDSVILLE, IN 47933 WEB SITE: WWW.BANJOCORP.COM E-MAIL: BANJOSALES@IDEXCORP.COM	
DESCRIPTION	2" CAP
PART NUMBER	200CAP