

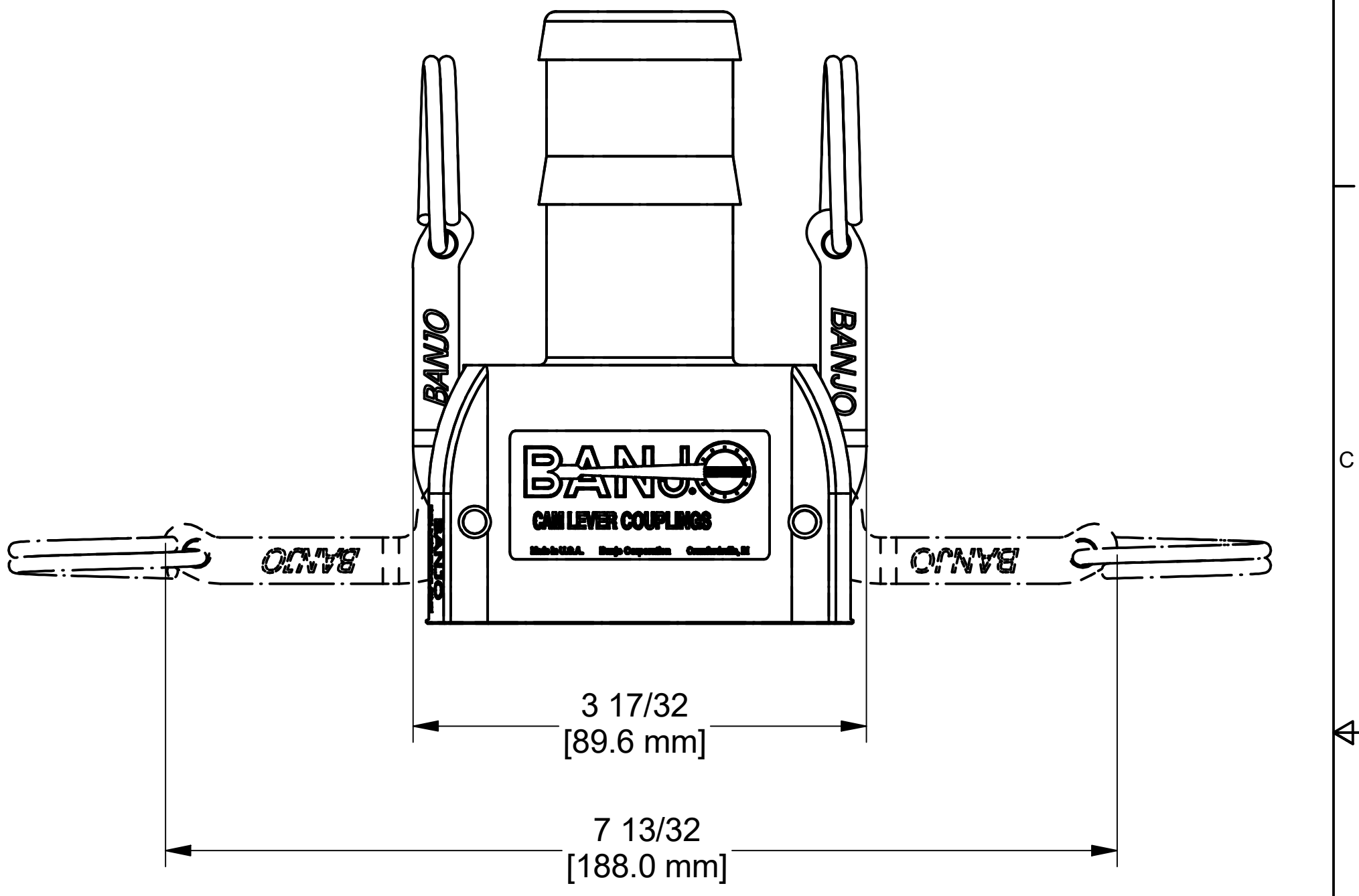

PARTS LIST				
ITEM	QTY	PART NUMBER	DESCRIPTION	
1	1	150(200)D	CAM LEVER COUPLING DECAL	
2	2	150(200)K	1 1/2" & 2" CAM ARM	
3	1	150G	1 1/2" Coupling Gasket	
4	1	150XC	1 1/2" Male Coupling X 1 1/2" Barb	
5	2	200P	CAM ARM PIN	





BANJO
CORPORATION

BANJO CORPORATION
 150 BANJO DRIVE, CRAWFORDSVILLE, IN 47933
 WEB SITE: WWW.BANJOCORP.COM
 E-MAIL: BANJOSALES@IDEXCORP.COM

DESCRIPTION
FEMALE CPLG 1-1/2" HOSE SHANK

PART NUMBER
150C

THIS DRAWING AND ALL INFORMATION CONTAINED THEREON ARE THE EXCLUSIVE PROPERTY OF BANJO CORPORATION.

UNLESS SPECIFICALLY NOTED, THIS DRAWING AND ITEMS SHOWN ON THIS DRAWING ARE SUBJECT TO CHANGE AT ANY TIME.