



## BACKUP ALARMS

### IMPORTANT SAFETY INFORMATION

Please read and follow the instructions in this manual carefully.

- For the installation of the Backup Alarm, a good understanding of truck and heavy equipment electrical systems and procedures, as well as a working knowledge of the installation and use of safety warning equipment is necessary.
- Before drilling into a vehicle's structure, make sure that both sides of the surface are free of anything that could be damaged.
- When locating the Backup Alarm, make sure that the location will not allow adverse weather conditions or obstructions to sound projection to cause a negative impact on its effectiveness.
- An effective Backup Alarm produces loud sounds which may cause permanent hearing loss. Take every precaution to avoid any hearing disability by following your employer's hearing conservation program. Check safety guidelines for instructions regarding the use of hearing protection.
- The vehicle's supply voltage **MUST BE** within the voltage rating as specified on the Backup Alarm.
- Inspect the Backup Alarm system often to make sure it is operating properly and that it is securely attached to the vehicle.
- Keep a copy of these instructions in a secure place and refer to them when maintaining or reinstalling the product. The operator of the backup alarm system must have a copy of these instructions.

**Warning:** *Failure to carry out all the safety procedures and Instructions may cause property damage, serious injury, or death.*

### INSTALLATION

#### Unpacking

After unpacking, check for any damage due to transportation. Do not install or operate the product if damaged. Contact the carrier immediately and file a damage claim stating the extent of damage.

Thoroughly check all information with the product, including

1. shipping labels etc. before removing them

#### Mounting

**Warning:** *This Alarm concentrates its audible alarm in the target hazard area. For maximum warning signal coverage, the alarm should be mounted approximately 4 ft. above ground level with the unit's sound ports facing the target hazard area. Make sure there are no obstructions to block the sound ports of the unit.*

**Choose a mounting location near the rear of the vehicle which provides protection from impact and adverse weather conditions yet still allows an unobstructed sound projection to the target hazard area.**

**CAUTION:** Both sides of the mounting surface must be clear of parts that could be damaged, such as brake lines, electrical wiring, or any other parts before drilling or cutting holes anywhere on the vehicle.

1. Decide on a mounting location for the alarm and user supplied switch.
  - If mounting holes do not exist, Set the backup alarm in the desired position and using the backup alarm as a template. Mark the centre of the mounting holes using either of the back or bottom holes depending on the desired mounting position.
  - Drill two 21/64" holes at 3 1/4" centers to mount unit.
  - Use 2PCS 5/16" cap screws with nuts and lock washers to mount unit.
  - Note: Unit can be mounted flush with back or on base.

2. Run an 18 gauge wire from the power source to the location of switch.

3. Run an 18 gauge wire from the switch to the installation location.

**WARNING:** *Improper grounding could cause the alarm to malfunction and result in death or serious injury to those who rely on it for safety. The ground connection (-) must be attached to a solid metal body or chassis part which will provide a dependable ground for the device while in use.*

4. Run an 18 gauge wire from the installation area to the nearest chassis ground. The battery is recommended.

5. Connect the positive terminal on the alarm to the 18 gauge wire for the switch.





## BACKUP ALARMS

6. Connect the negative terminal on the alarm to the 18 gauge wire for the chassis ground.
7. Allow excess wire to allow for servicing the alarm after installation.
8. Check the wiring and test for proper operation.

### SPECIFICATIONS

Voltage	12-48V
Current 0.15 A	0.15A
Sound Output 97 dB (in 3.28 ft)	97dB (in 3.28ft)
Operating Temperature	-20°F to 185°F
Approvals	SAE J994
Environmental Rating	Indoor/Outdoor Use, IP66

#### WARNING:

- **Never operate a vehicle when the alarm is not working properly; the lives or safety of others may depend on the alarm signal for their safety.**
  - **An effective Backup Alarm produces loud sounds which may cause permanent hearing loss or damaged hearing. To determine if you need protection, check with the safety guidelines and hearing program at your place of employment.**
  - **Hearing loss can occur from short exposures to very loud sounds or from longer exposures to moderately loud sounds. For guidance, refer to federal, state, or local recommendations. OSHA Standard 1910.95 offers guidance on "Permissible Noise Exposure."**
  - **Optimum sound levels will be reduced if Backup Alarm becomes blocked by a foreign substance such as mud or snow etc. When cleaning, make sure that the sound ports are clear.**
  - **Even when the warning system is operating properly, it may not alert everybody. Some may not hear or heed the warning signal.**
- Remember this and continue to operate your vehicle cautiously.**
- **Testing the Backup Alarm should be listed on the daily maintenance log. The units on operating vehicles must be tested every day prior to the vehicles' operation. Results of this test must be entered in the maintenance record.**
  - **Supervisors and operators must know that this equipment MUST be checked for proper operation at the beginning of every shift or operating period.**
  - **It is also important that everyone understands how to safely operate this warning system before using it.**





## BACKUP ALARMS

Figure 1

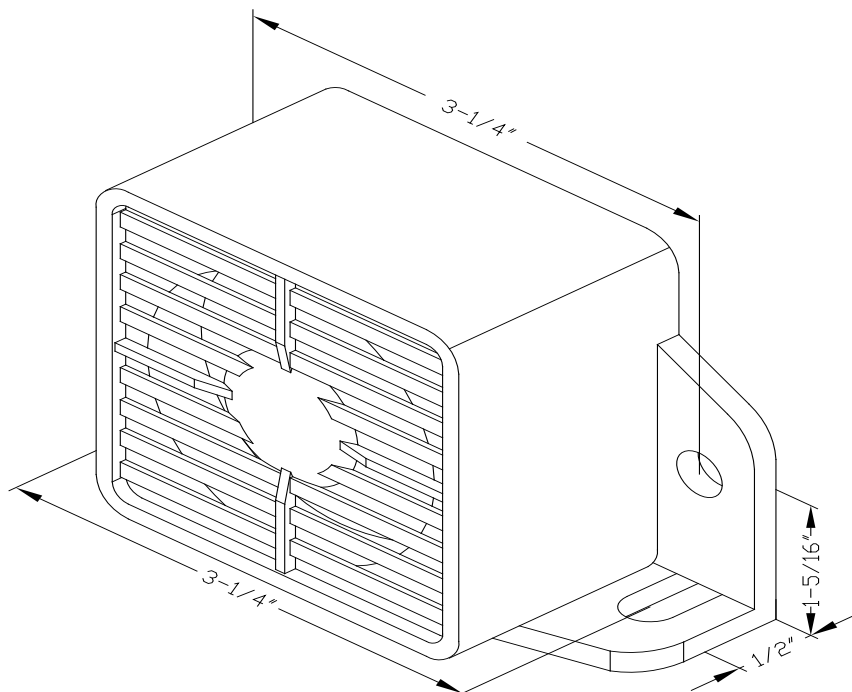
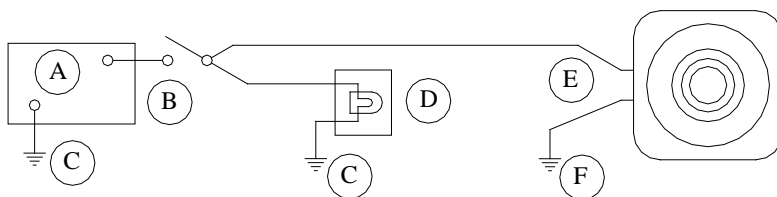

Figure 2



- A. **Battery**
- B. **Switch**
- C. **Ground**
- D. **Backup Light**
- E. **Alarm**
- F. **Ground**

